

Advanced Satellite Communications

VSAT

Leila Z. Ribeiro
TCOM 508 - Spring 2001

George Mason
University

1

Source Material:

-
- Pratt & Bostian updated material for second edition. (With the authors' permission)
 - VSAT current material from service providers' web pages.

2

Important Note

- Copyright for some of the figures presented in this lecture is retained by INTELSAT, the ITU-R, and Wiley (who will be the publisher of the second edition of the textbook).
- Slides should not be reproduced without permission.

3

Agenda

- Introduction
- Applications
- Implementation
- Access Control
- Access Methods
- Interference, Modulation and Coding
- Earth Stations

4

Introduction

5

Introduction

- VSAT = Very Small Aperture Terminal
- Early Earth Stations in commercial systems were very large and expensive (30 m).
- Need to make system more affordable to end user:
 - Increased transmit power from satellite.
 - Higher frequencies
- Result: Smaller ES antenna size required.

6

Large Antenna Systems

- Breakpoint between “large” and “small” antennas is at about 100 wavelengths.
- Above breakpoint, “back-fed” configurations such as Cassegrain or Gregorian are economically and technically viable (subreflectors need to be at least 10 wavelengths).
- Below breakpoint, terminals called Small Aperture Terminals.
- Smaller Antennas → Tighter Link Budgets

7

Typical Antenna Sizes

- At C-band: below 5 meters (100 wavelength at 6 GHz).
- Extrapolation of terminology:
USAT = Ultra Small Aperture Terminal.
- Standard VSAT antennas (Intelsat tables next)
- Smaller antennas are also included in the concept of VSAT or USAT (DTH, MSS, etc). These systems will be studied separately in this course.

8

Intelsat Standard for VSAT antennas

Table 9.1
 Summary of Characteristics for the INTELSAT VSAT IBS Antennas
 From *INTELSAT Earth Station Standards (IESS) 207 (C-Band) and 208 (Ku-Band) (2)*

C-Band Antenna Standard	F1	H4	H3	H2
G/T (4 GHz), dB/K	22.7	22.1	18.3	15.1
Typical Antenna Diameter, m	3.5 – 5.0	3.5 – 3.8	2.4	1.8
Voltage Axial Ratio (Circular Polarization):	1.09	1.09	1.3	1.3
XPD Isolation Value, dB:	27.3 dB	27.3 dB	17.7 dB	17.7 dB
Ku-Band Antenna Standard	E1		K3	K2
G/T (11 GHz), dB/K	25.0		23.3	19.8
Typical Antenna Diameter, m	2.4 – 3.5		1.8	1.2
Voltage Axial Ratio (Linear Polarization):	31.6		20.0	20.0
XPD Isolation Value, dB:	30.0 dB		26.0 dB	26.0 dB



9

Picture copyrights on introductory slides. Reproduction with permission only.

Applications

10

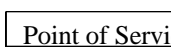
VSAT SYSTEMS

- Underlying objective of VSAT Systems:
bring the service directly to the end-user
- Major reasons for doing this
 - Reduce hierarchical distribution network (make more efficient and faster - e.g. POS credit)
 - Reduce distribution costs 
 - “Leapfrog” technology in developing countries (e.g. VSAT/WLL) 

11

VSAT/WLL - 1

- Telecommunications and roads are the two major economic growth requirements for developing countries
- Major telecommunications infrastructure does not exist in many developing countries
- **SOLUTION**
 - Distribute links to communities by satellite/VSAT
 - Use Wireless Local Loop from the VSAT

12

VSAT/WLL - 2

- The geostationary satellite is used to link a large number of VSATs with the main switching center in a large city.
- Each VSAT acts as the link to the local switching center in the village or rural community, with the final mile of the telephony link being carried over a Wireless Local Loop.

13

VSAT/WLL - 3

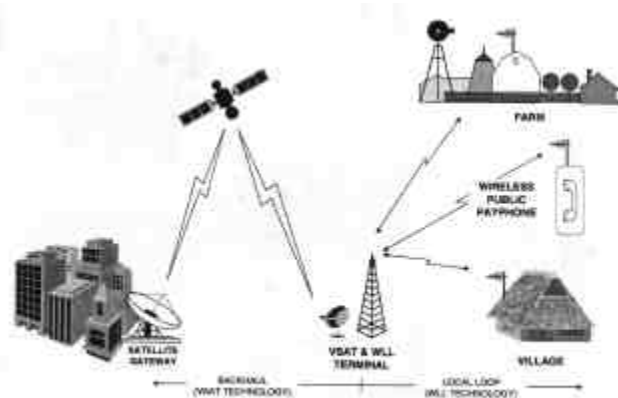

Fig. 2.5 in: INTELSAT VSAT Handbook, September 1998. Available from Application Support and Training, INTELSAT, 3400 International Drive, NW, Washington, DC 20008-3098, USA

14

VSAT/WLL – 4

User density dependency

- Economic advantages of VSAT/WLL solution depends primarily on user density.
- Physical distances, major transportation routes, and geographic barriers, as well as the individual country's demographics and political influences, can alter the breakpoints.

15

Motivation to use VSAT/WLL

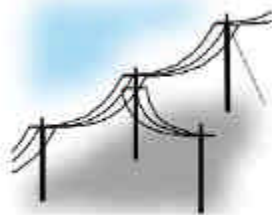

vs



- The last mile problem
- Hard to reach areas
- Reliability
- Time to deploy (4-6 months vs. 4-6 weeks)
- Flexibility
- Cost

Source: www.bhartibt.com

16

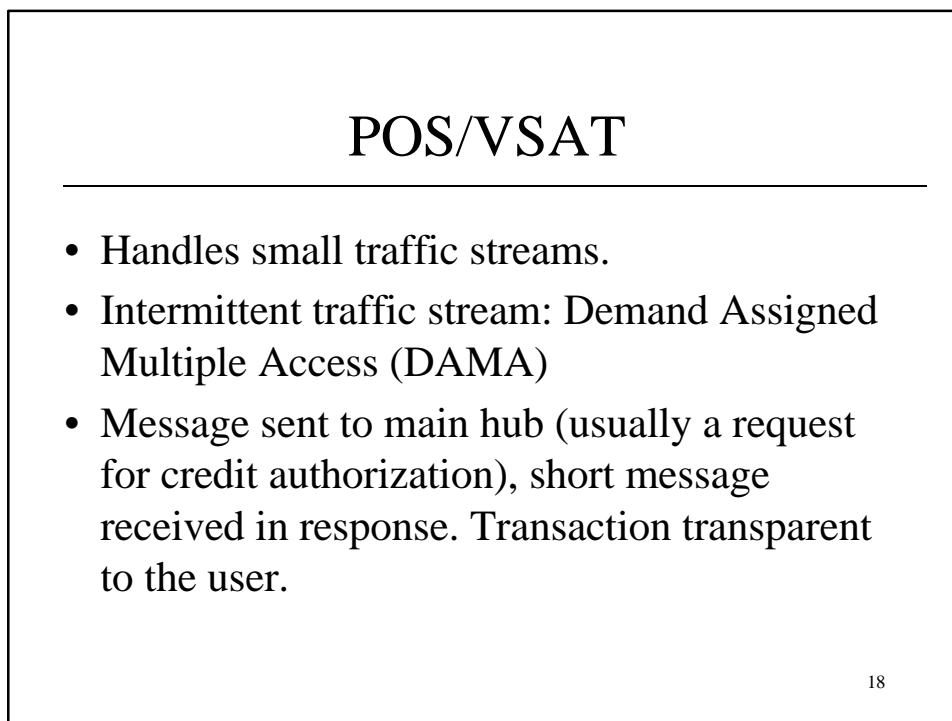
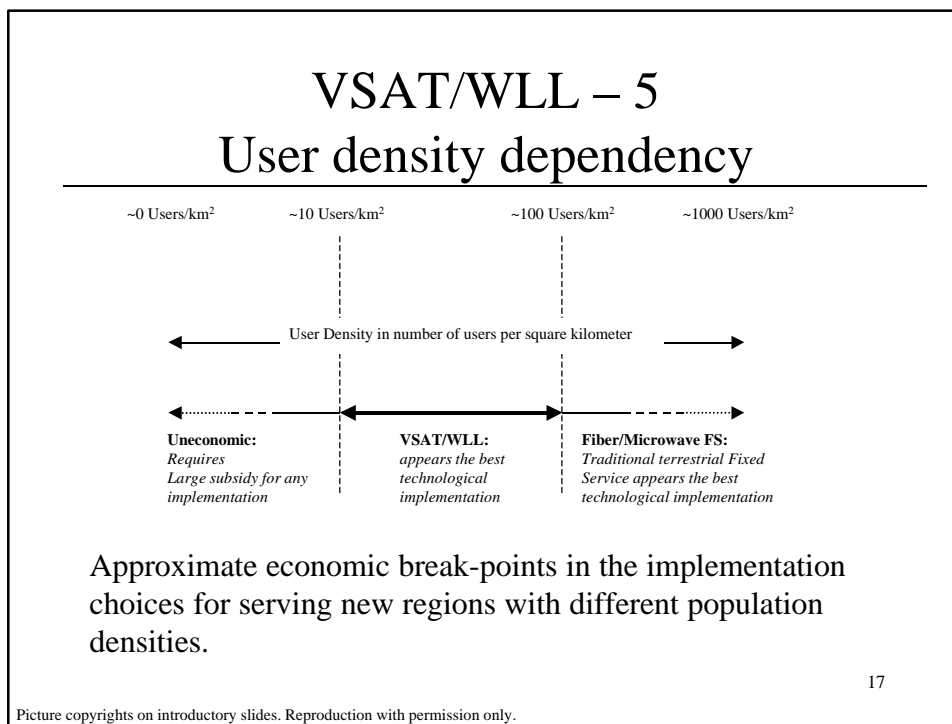

Implementations

19

VSAT IMPLEMENTATION - 1

- There are several ways VSAT services might be implemented
 - *One-Way* (e.g. TV Broadcasting satellites)
 - *Split-Two-Way (Split IP) Implementation* (return link from user is not via the satellite; e.g. DirecTV)
 - *Two-Way Implementation* (up- and down-link)

We will be looking at Two-Way Implementation only 

20

VSAT IMPLEMENTATION - 2

- There are basically two ways to implement a VSAT Architecture
- **STAR**
 - VSATs are linked via a HUB
- **MESH**
 - VSATs are linked together without going through a large hub

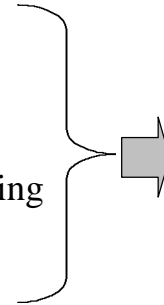

21

VSAT IMPLEMENTATION - 3



Higher Propagation delay
 Used by TDMA VSATs
 High central hub investment
 Smaller VSAT antenna sizes (1.8 m typically)
 Lower VSAT costs
 Ideally suited for interactive data applications
 Large organizations, like banks, with centralized data processing requirements

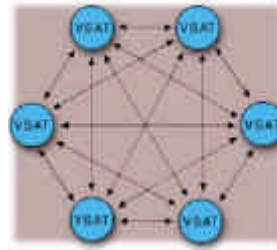

Lower Propagation delay (250 ms)
 Used by PAMA/DAMA VSATs
 Lower central hub investment
 larger VSAT antenna sizes (3.8 m typically)
 Higher VSAT costs
 Suited for high data traffic
 Telephony applications and point-to-point high-speed links

22

Source: www.bhartibt.com

VSAT STAR ARCHITECTURE - 2

- In this network architecture, all of the traffic is routed via the master control station, or Hub.
- If a VSAT wishes to communicate with another VSAT, they have to go via the hub, thus necessitating a “double hop” link via the satellite.
- Since all of the traffic radiates at one time or another from the Hub, this architecture is referred to as a STAR network.

23

VSAT STAR ARCHITECTURE - 2

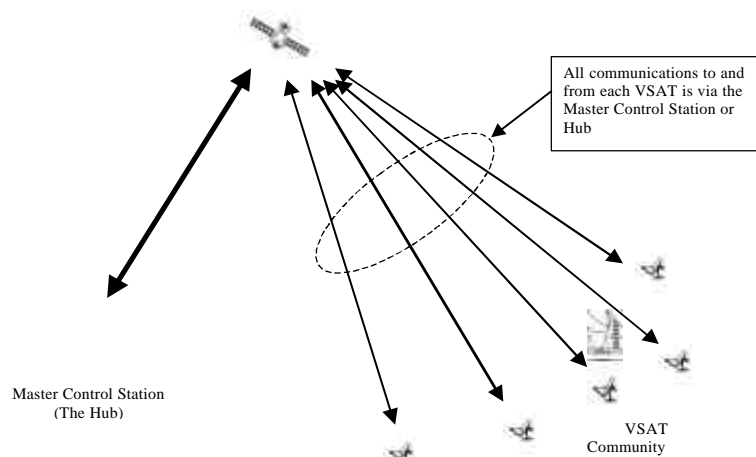

24

Picture copyrights on introductory slides. Reproduction with permission only.

VSAT STAR ARCHITECTURE - 3

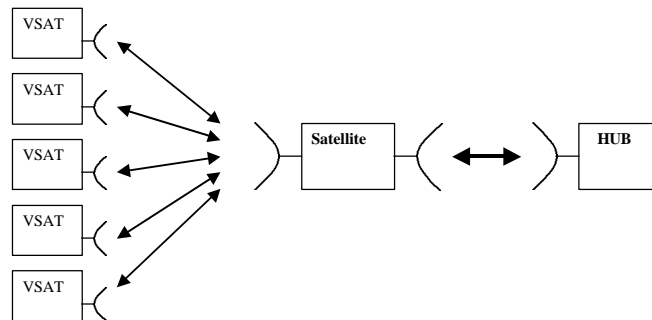

Topology of a **STAR** VSAT network viewed from the satellite's perspective
Note how the VSAT communications links are routed via the satellite to the Hub in all cases.

25

VSAT MESH ARCHITECTURE - 1

- In this network architecture, each of the VSATs has the ability to communicate directly with any of the other VSATs.
- Since the traffic can go to or from any VSAT, this architecture is referred to as a MESH network.
- It will still be necessary to have network control and the duties of the hub can either be handled by one of the VSATs or the master control station functions can be shared amongst the VSATs.

26

VSAT MESH ARCHITECTURE - 2

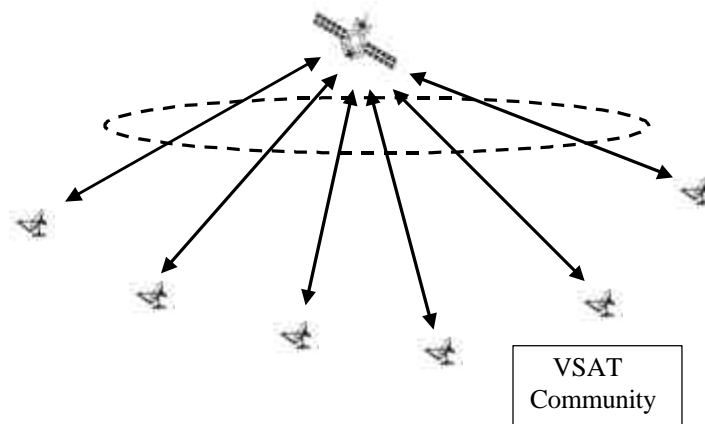

27

Picture copyrights on introductory slides. Reproduction with permission only.

VSAT MESH ARCHITECTURE - 3

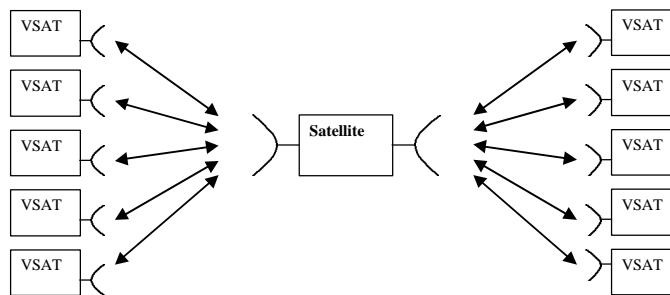

Topology of a **MESH** VSAT network from the satellite's perspective
 Note how all of the VSATs communicate directly to each other via the satellite without passing through a larger master control station (Hub).

28

ADVANTAGES OF STAR

- Small uplink EIRP of VSAT (which can be a hand-held telephone unit) compensated for by large G/T of the Hub earth station
- Small downlink G/T of user terminal compensated for by large EIRP of Hub earth station
- Can be very efficient when user occupancy is low on a per-unit-time basis

29

DISADVANTAGES OF STAR

- VSAT terminals cannot communicate directly with each other; they have to go through the hub
- VSAT-to-VSAT communications are necessarily double-hop
- GEO STAR networks requiring double-hops may not meet user requirements from a delay perspective

30

ADVANTAGES OF MESH

- Users can communicate directly with each other without being routed via a Hub earth station
- VSAT-to-VSAT communications are single-hop
- GEO MESH networks can be made to meet user requirements from a delay perspective

31

DISADVANTAGES OF MESH

- Low EIRP and G/T of user terminals causes relatively low transponder occupancy
- With many potential user-to-user connections required, the switching requirements in the transponder will almost certainly require On-Board Processing (OBP) to be employed
- OBP is expensive in terms of payload mass and power requirements

32

Access Control

33

Access Control Protocols

- **International Standards Organization** has specified the **Open Systems Interconnection – ISO/OSI**.
- ISO-OSI considers a seven layer “stack” for interconnecting data terminals. Conceptual model.
- Satellite Link occupies the physical layer (bits transport)
- VSAT Network must have terminal controllers at each end of the link (network and link layers).
- Network control center is responsible for the remaining layers.

34

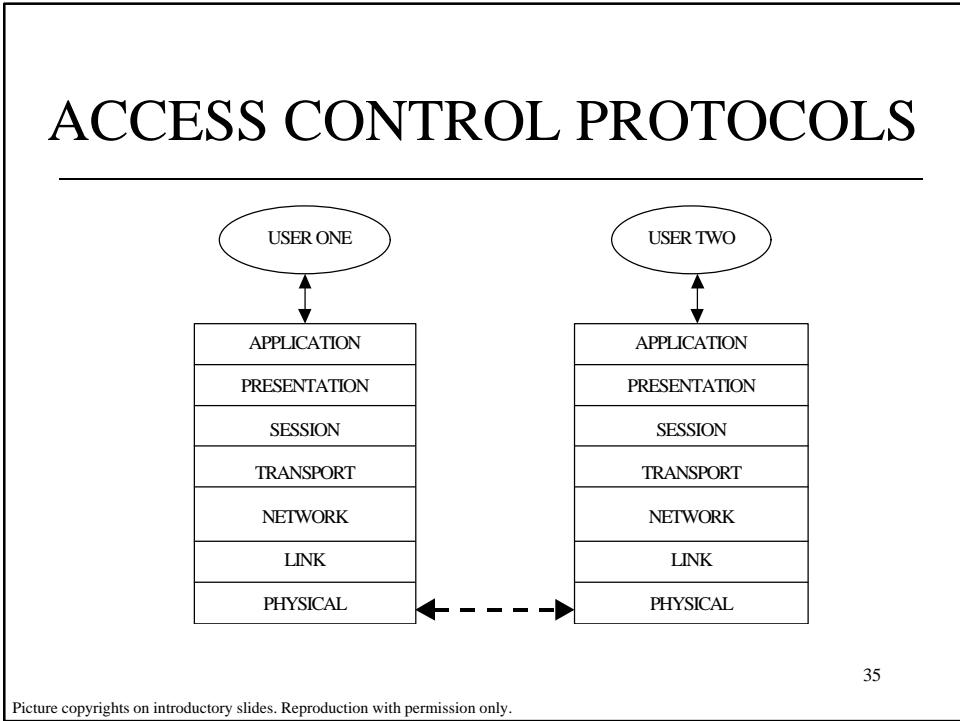

Access Control Protocols

In this example, User One and User Two are conducting a two-way communications session with each other. Each user interacts with their local device (e.g. a computer keyboard/visual display unit) at the Application Layer of the ISO-OSI stack. Their transaction is then routed via the various layers, with suitable conversions, etc., until the content is ready to be transmitted via the physical layer (where the satellite link is).

36

Delay Considerations

Satellite Scenario:

- Typical slant path range for GEO satellite: 39,000 km
- One way transmission: ES → Satellite → ES: 2 x Range
- One way delay: $2 \times (\text{range/velocity}) = 260 \text{ ms}$

Fiber Optic Transcontinental Link:

- 4000 km or about 13 ms delay

Additionally to either case: Processing delay.

- Several tens to over a hundred ms.

37

DELAY CONSIDERATIONS - 1

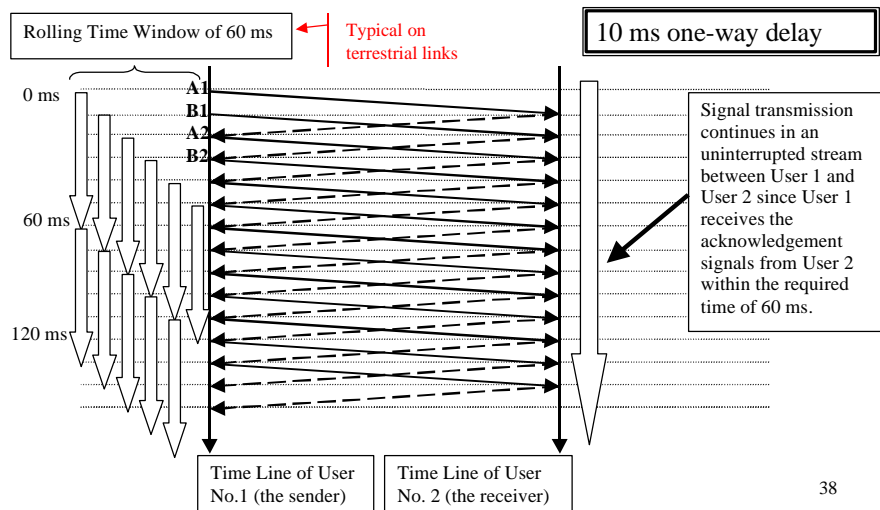

Picture copyrights on introductory slides. Reproduction with permission only.

38

DELAY CONSIDERATIONS - 2

Previous Slide: Illustration of a communications link with a 10 ms one-way delay and a 60 ms window

In this example, a packet or frame is sent at instant A1 from User 1 to User 2. User 2 receives the transmission without error and sends an acknowledgement back, which is received at instant A2, 20 ms after the initial transmission from User 1. This is well within the time window of 60 ms. The time window rolls forward after each successful acknowledgement. Thus the transmission from User 1 at instant B1 is received by User 2, and the acknowledgement received by User 2 at instant B2, within the new rolling time window of 60 ms. Each packet or frame is successfully received in this example.

39

DELAY CONSIDERATIONS - 3

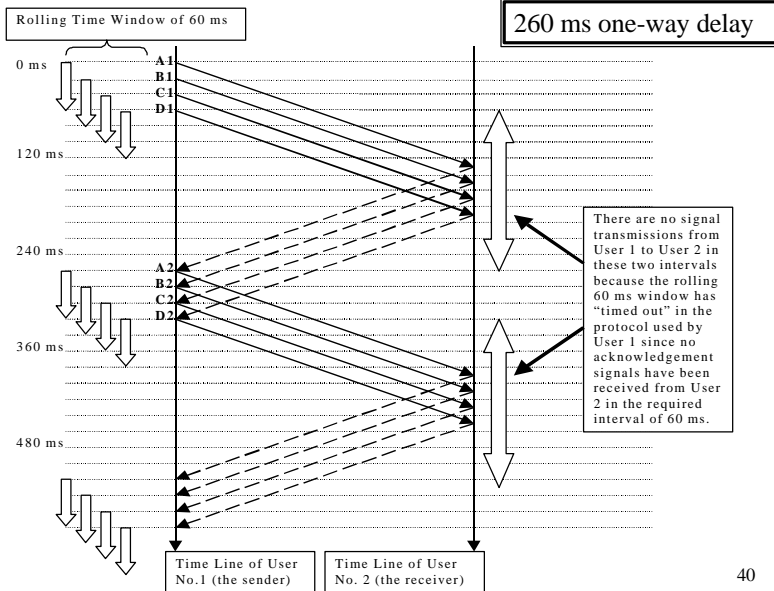

40

Picture copyrights on introductory slides. Reproduction with permission only.

DELAY CONSIDERATIONS - 4

Previous Slide: Illustration of a communications link with a 260 ms one-way delay and a 60 ms window

In this example, a packet or frame is sent at instant A1 from User 1 to User 2. User 2 receives the transmission without error and sends an acknowledgement back, which is received at instant A2, 260 ms after the initial transmission from User 1. Unfortunately, instant A2 is well after the rolling window time out of 60 ms. Transmissions from User 1 are automatically shut down by the protocol when the time out of 60 ms is exceeded. Ignoring processing delays in this example, User 1 is only transmitting for 60 ms in every 260 ms, thus drastically lowering the throughput. Again, no propagation errors are assumed to occur.

41

Protocol Changes - 1

- VSAT protocol acts as processing buffer to separate the satellite network from the terrestrial network (spoofing).
- VSAT networks are normally maintained as independent, private networks, with the packetization handled at the user interface units of the VSAT terminals.
- The satellite access protocol (with a larger time-out window) is handled in the VSAT/Hub Network kernel, which also handles packet addressing, congestion control, packet routing and switching, and network management functions.
- Protocol conversion and, if necessary, emulation is handled by the Gateway equipment.

42

PROTOCOL CHANGES

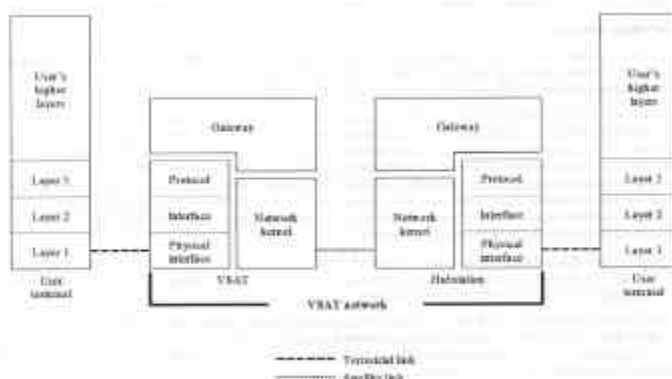

Fig. 2.2.1 of "VSAT Systems and Earth Stations", Supplement No. 3 to the Handbook on Satellite Communications, International Telecommunications Union, Geneva, 1994 (for updates on this handbook, please refer to <http://www.itu.int>)⁴³

Picture copyrights on introductory slides. Reproduction with permission only.

Design Considerations

- Using basic concepts introduced in TCOM507: Link Budget, Multiple access, Modulation Schemes.
- Frequency Allocation: Considered a Fixed Satellite Service (FSS), allocation frequencies at :
 - C band (4/6 GHz)
 - Ku band (14/11 GHz) increasingly common today
 - Ka band (30/20 GHz) considered for future applications
- Small antennas → Small sensitivity (small G/T).
- Restrictions in transmitted power flux density from satellite to satisfy regulatory restrictions due to frequency sharing with terrestrial systems (C band). A common solution is to use **spread-spectrum** techniques.

44

Access Methods

45

Multiple Access Possibilities

- Choice aiming to maximize the use of common satellite and other resources amongst all VSAT sites.

Methods considered:

- Pre-Assigned Multiple Access (PAMA)
- Demand Assigned Multiple Access (DAMA)
- FDMA = Frequency Division Multiple Access
- TDMA = Time Division Multiple Access
 - Fixed Assigned TDMA
 - ALOHA & Slotted ALOHA
 - Dynamic Reservation
- CDMA = Code Division Multiple Access

46

Star Inbound FDMA – Example (cont.)

- The 64 kbit/s information rate is contained in a bandwidth of 96 kHz when transmitted to the satellite.
- The bandwidth of the satellite transponder (from frequency f1 to frequency f2) is divided up, or channelized, into increments of 96 kHz so that a large number of VSATs can access the transponder at the same time.
- Each of the 96 kHz channels requires a certain amount of spectrum on either side to guard against drift in frequency, poor VSAT filtering, etc. The 96 kHz channels plus the guard bands on either side add up to a channel allocation of about 120 kHz per VSAT.
- From a spectrum allocation viewpoint, therefore, a typical 36 MHz satellite transponder would permit the simultaneous access of 300 VSATs, each of which is transmitting the equivalent of a 64 kbit/s voice channel.
- Because each VSAT uses a single channel continuously on the uplink, it is often referred to as **SCPC** - Single Channel Per Carrier - FDMA.

49

FDMA – Implementation Options

• **PAMA (Pre Assigned Multiple Access)** - implies that the VSATs are pre-allocated a designated frequency. Equivalent of the terrestrial leased line solutions, PAMA solutions use the satellite resources constantly. Consequently there is no call setup delay which makes them most suited for interactive data applications or high traffic volumes. As such PAMA is **used typically to connect high data traffic sites within an organization**. SCPC (Single Channel Per Carrier) refers to the usage of a single satellite carrier for carrying a single channel of user traffic. The frequency is allocated on a pre-assigned basis in case of SCPC VSAT's. The term SCPC VSAT is often used interchangeably with PAMA VSAT.

• **DAMA (Demand Assigned Multiple Access)** - network uses a pool of satellite channels, which are available for use by any station in that network. On demand a pair of available channels are assigned so that a call can be established. Once the call is completed, the channels are returned to the pool for an assignment to another call. Since the satellite resource is used only in proportion to the active circuits and their holding times, this is **ideally suited for voice traffic and data traffic in batch mode**. DAMA offers point to point voice, fax, and data requirements and supports video conferencing.

50

Outbound Link - TDM

- Return link: Hub → Satellite → VSATs
- Star Topology: typically a single, wide-band stream in Time Division Multiplexing (TDM) format...

Note: What is the difference between TDM and TDMA???
 (usually used interchangeably, but not exactly the same)

Answer: In TDM, all multiplexed data channels come from the same transmitter, which means that clock and carrier frequencies do not change. In TDMA, each frame contains a number of independent transmissions (time slots contain information from different data sources usually transmitted from different locations).

51

Example: Outbound Link - TDM

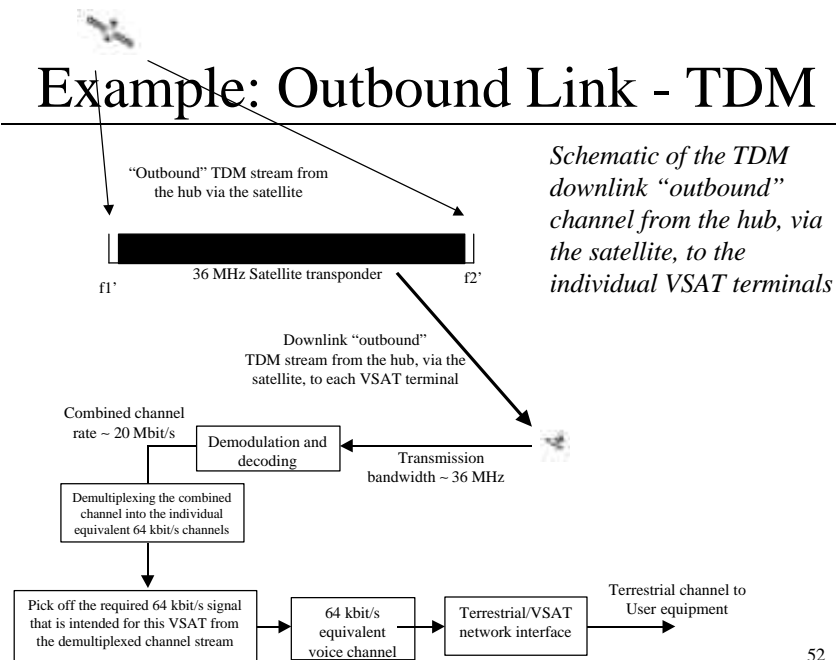

52

Example: Outbound Link – TDM (cont.)

- The 300 individual, narrow-band, “inbound” channels received at the hub from the VSATs are sent back to the VSATs in a single, wide-band, “outbound” TDM stream at a combined transmission rate ~20 Mbit/s.
- Each VSAT receives the downlink TDM stream and then demodulates and decodes it (i.e. changes the modulated bandpass signal into a baseband line code and removes the FEC).
- The line code is then passed through a demultiplexer which is used to extract the required part of the stream that contains the equivalent 64 kbit/s voice channel destined for that VSAT terminal.
- Carrier recovery and bit recovery circuits are used in the receiver in order to be able to identify the exact position of the required VSAT channel in time. The bandwidth of the satellite transponder (from frequency f_1' to frequency f_2') is fully occupied in this example.

53

Transponder Sharing: TDM-Outbound, FDMA-Inbound

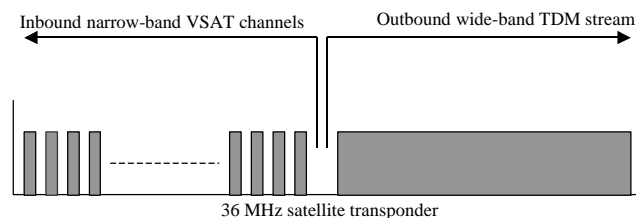

In the example here, 18 MHz of spectrum is allocated for each side of the system connection. On the uplink to the satellite, the collection of FDMA narrow-band channels transmitted by the VSATs co-exists in the same transponder with the wide-band TDM stream transmitted up by the hub. On the downlink from the satellite, the hub receives the collection of individual narrow-band channels while the wide-band TDM downlink stream is received by each VSAT. The precise frequency assignment can vary to suit the capacity of the VSAT network.

54

Another option for Inbound Link Multi-Frequency TDMA (MF-TDMA)

- If we used TDMA instead of FDMA, in the example, each VSAT would have to be able to transmit (at discontinuous intervals) at a power much higher than that need by one single channel (larger bandwidth).
- Solution → **Hybrid TDMA-FDMA approach**
- Each VSAT transmits a burst rate at 5 times the bandwidth of a normal single VSAT single-channel rate.
- Equivalent to say that each frequency is shared in 5 time-slots, one for each VSAT.
- Saves power at VSAT transmitter compared to “pure” TDMA.

55

Example: Inbound MF-TDMA

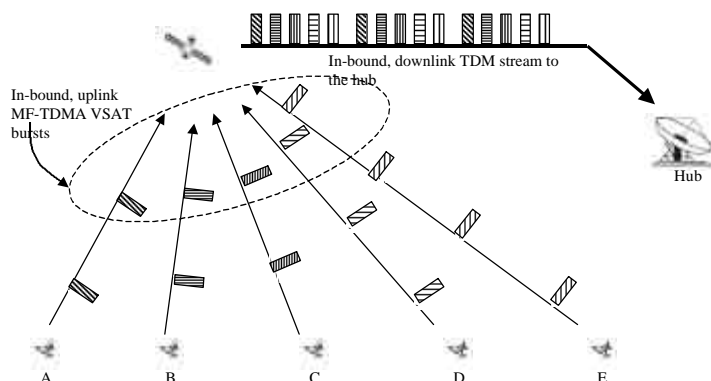

56

Example: Inbound MF-TDMA (cont.)

- In this particular case, each group of five VSAT terminals (A, B, C, D, and E) share the same frequency assignment, that is they all transmit at the same frequency.
- However, they each have a unique time slot in the TDMA frame when they transmit, so that they do not interfere with each other.
- The bursts from each VSAT are timed to arrive at the satellite in the correct sequence for onward transmission to the hub.
- Other frequencies (not shown in the picture) shared among other groups of five VSATs.

57

CDMA Option

- Adds spectral efficiency in interference-limited environments (facilitates frequency reuse).
- Allows reception below noise floor due to signal spreading in larger bandwidth (spread-spectrum).
- Initially employed for encryption and military purposes.
- Off-axis emission is closely specified by the ITU-R and is a key element in Up-Link Power Control design. When LEO constellations are sharing the same frequency bands as GEO systems, the use of CDMA may confer some advantages for coordination purposes at the expense of system capacity.

58

How a VSAT can cause interference to other satellite systems

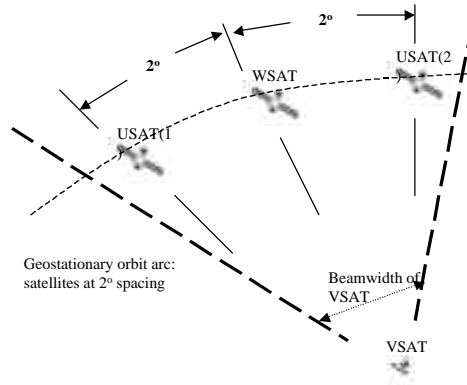

- In this example, the VSAT is transmitting to a wanted satellite (WSAT) but, because the antenna of the VSAT is small, its beam will illuminate two other adjacent, unwanted satellites (USATs) that are 2° away in the geostationary arc.

- In a like manner, signals from USAT (1) and USAT(2) can be received by the VSAT, thus causing the potential for interference if the frequencies and polarizations used are the same.

59

Interference, Modulation and Coding

60

Interference Scenario - 1

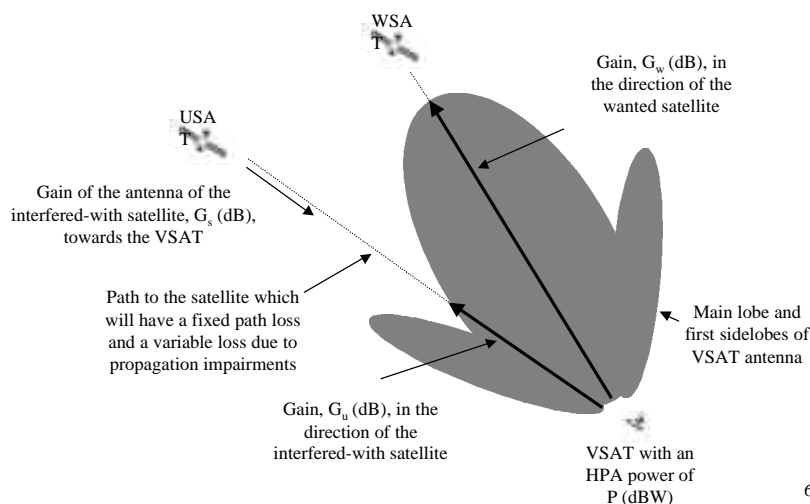

Interference Scenario - 2

- Previous slide shows the interference geometry between a VSAT and a satellite of another system.
- The EIRP of the VSAT towards the interfered-with satellite [$P(\text{dBW}) + G_u(\text{dB})$] is the interference power from the VSAT into the interfered-with satellite.
- To develop the interference link budget, the Gain of the interfered-with satellite in the direction of the VSAT, G_s (dB), would be used, plus any additional effects along the path (such as site shielding, if used, expected rain effects for given time percentages, etc.)

62

Coding and Modulation

Modulation Scheme:

- High index modulation schemes use bandwidth more effectively.
- High index modulation schemes also require more link margin, more amplifier linearity.
- They are also more susceptible to interference and harder to implement.
- Typically systems work with BPSK or QPSK.

Coding Scheme:

- Inner code.
- Outer interleaving code (Reed-Solomon) to protect against burstiness.

63

Earth Stations

64

VSAT Earth Station - 1

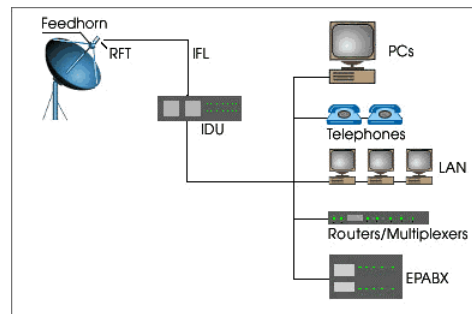

- Outdoor Unit (ODU)
- Inter-facility link (IFL)
- Indoor Unit (IDU)

Source: www.bhartibt.com

65

VSAT Earth Station - 2

- The VSAT Outdoor Unit (ODU) is located where it will have a clear line of sight to the satellite and is free from casual blockage by people and/or equipment moving in front of it. It includes the Radio Frequency Traseiver (RFT).
- The Inter Facility Link (IFL) carries the electronic signal between the ODU and the Indoor Unit (IDU) as well as power cables for the ODU and control signals from the IDU.
- The IDU is normally housed in a desktop computer at the User's workstation and consists of the baseband processor units and interface equipment (e.g. computer screen and keyboard). The IDU will also house the modem and multiplexer/demultiplexer (mux/demux) units if these are not already housed in the ODU.

66

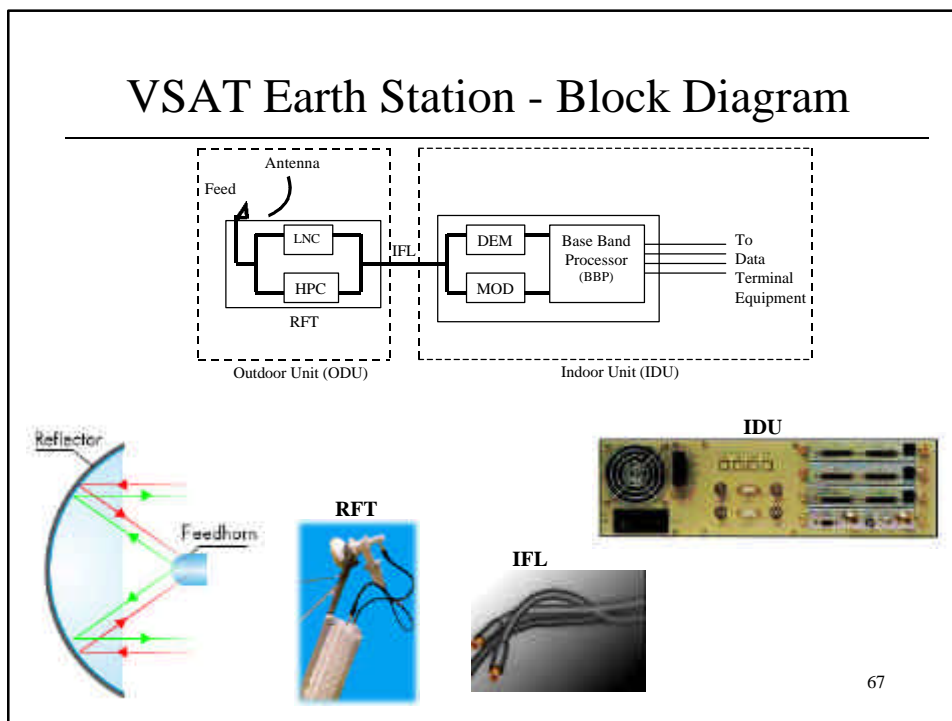

VSAT Earth Station – Blocks Description

- The Low Noise Converter (LNC) takes the received RF signal and, after amplification, mixes it down to IF for passing over the inter facility link (IFL) to the IDU.
- In the IDU, the demodulator extracts the information signal from the carrier and passes it at base band to the Base Band Processor.
- The data terminal equipment then provides the application layer for the user to interact with the information input. On the transmit operation, the user inputs data via the terminal equipment to the baseband processor and from there to the modulator.
- The modulator places the information on a carrier at IF and this is sent via the inter facility link to the High Power Converter (HPC) for upconversion to RF, amplification, and transmission via the antenna to the satellite.

68

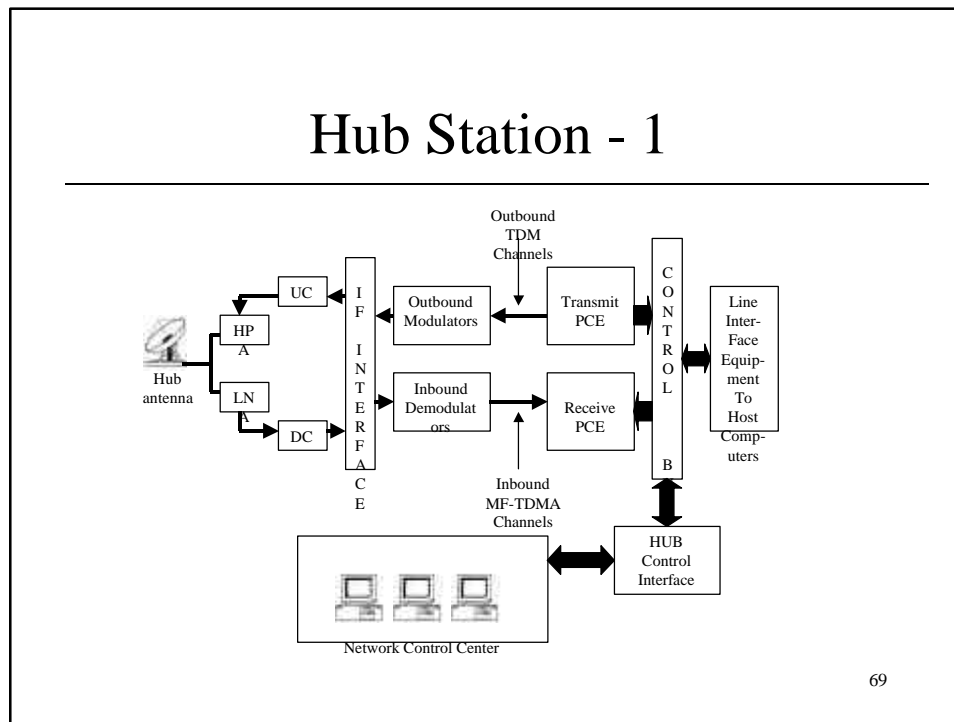

Hub Station - 2

- The line interface equipment handles the terrestrial ports to the host computer.
- The control bus via the hub control interface allows all of the transmit, receive, and switching functions to be carried out.
- The transmit Processing and Control Equipment (PCE) prepares the TDM stream for the outbound link to the VSATs.
- This stream passes through the IF interface (the equivalent of the interfacility link of the VSAT) to the Up-Converter (UC) that mixes the IF to RF.
- The High Power Amplifier (HPA) amplifies the TDM stream and the antenna transmits the signal.
- On the receive side, the antenna passes the individual inbound MF-TDMA signals to the Low Noise Amplifier (LNA) for amplification prior to Down Conversion (DC), demodulation, and so on to the user.