



Getting Started with μ Vision2

**and the C51 Microcontroller
Development Tools**

User's Guide 02.2001

Information in this document is subject to change without notice and does not represent a commitment on the part of the manufacturer. The software described in this document is furnished under license agreement or nondisclosure agreement and may be used or copied only in accordance with the terms of the agreement. It is against the law to copy the software on any medium except as specifically allowed in the license or nondisclosure agreement. The purchaser may make one copy of the software for backup purposes. No part of this manual may be reproduced or transmitted in any form or by any means, electronic or mechanical, including photocopying, recording, or information storage and retrieval systems, for any purpose other than for the purchaser's personal use, without written permission.

Copyright © 1997-2001 Keil Elektronik GmbH and Keil Software, Inc.
All rights reserved.

Keil C51™ and μ Vision™ are trademarks of Keil Elektronik GmbH.
Microsoft®, and Windows™ are trademarks or registered trademarks of Microsoft Corporation.
PC® is a registered trademark of International Business Machines Corporation.

NOTE

This manual assumes that you are familiar with Microsoft Windows and the hardware and instruction set of the 8051 microcontrollers.

Every effort was made to ensure accuracy in this manual and to give appropriate credit to persons, companies, and trademarks referenced herein.

Preface

This manual is an introduction to the Keil Software development tools for the 8051 family of microcontrollers. It introduces new users and interested readers to our products. This user's guide contains the following chapters.

“Chapter 1. Introduction” gives an overview and discusses the different products that Keil Software offers for the 8051 microcontroller families.

“Chapter 2. Installation” describes how to install the software and how to setup the operating environment for the tools.

“Chapter 3. Development Tools” describes the major features of the μ Vision2 IDE with integrated debugger, the C compiler, assembler, and utilities.

“Chapter 4. Creating Applications” describes how to create projects, edit source files, compile and fix syntax errors, and generate executable code.

“Chapter 5. Testing Programs” describes how you use the μ Vision2 debugger to simulate and test your entire application.

“Chapter 6. μ Vision2 Debug Functions” discusses built-in, user, and signal functions that extended the debugging capabilities of μ Vision2.

“Chapter 7. Sample Programs” provides several sample programs that show you how to use the Keil 8051 development tools.

“Chapter 8. RTX-51 Real-Time Operating System” discusses RTX-51 Tiny and RTX-51 Full and provides an example program.

“Chapter 9. Using On-chip Peripherals” shows how to access the on-chip 8051 peripherals with the C51 compiler. This chapter also includes several Application Notes.

“Chapter 10. CPU and C Startup Code” provides information on setting up the 8051 CPU for your application.

“Chapter 11. Using Monitor-51” discusses how to initialize the monitor and install it on your target hardware.

“Chapter 12. Command Reference” briefly describes the commands and controls available in the Keil 8051 development tools.

Document Conventions

This document uses the following conventions:

Examples	Description
README.TXT	<p>Bold capital text is used for the names of executable programs, data files, source files, environment variables, and commands you enter at the command prompt. This text usually represents commands that you must type in literally. For example:</p> <p style="text-align: center;">CLS DIR BL51.EXE</p> <p>Note that you are not required to enter these commands using all capital letters.</p>
Courier	<p>Text in this typeface is used to represent information that displays on screen or prints at the printer.</p> <p>This typeface is also used within the text when discussing or describing command line items.</p>
<i>Variables</i>	<p>Text in italics represents information that you must provide. For example, <i>projectfile</i> in a syntax string means that you must supply the actual project file name.</p> <p>Occasionally, italics are also used to emphasize words in the text.</p>
Elements that repeat...	<p>Ellipses (...) are used to indicate an item that may be repeated.</p>
Omitted code : :	<p>Vertical ellipses are used in source code listings to indicate that a fragment of the program is omitted. For example:</p> <pre>Void main (void) { : : while (1);</pre>
[<i>Optional Items</i>]	<p>Double brackets indicate optional items in command lines and input fields. For example:</p> <pre>C51 TEST.C PRINT [(filename)]</pre>
{ <i>opt1</i> <i>opt2</i> }	<p>Text contained within braces, separated by a vertical bar represents a group of items from which one must be chosen. The braces enclose all of the choices and the vertical bars separate the choices. One item in the list must be selected.</p>
Keys	<p>Text in this sans serif typeface represents actual keys on the keyboard. For example, "Press Enter to continue."</p>
Point	<p>Move the mouse until the mouse pointer rests on the item desired.</p>
Click	<p>Quickly press and release a mouse button while pointing at the item to be selected.</p>
Drag	<p>Press the left mouse button while on a selected item. Then, hold the button down while moving the mouse. When the item to be selected is at the desired position, release the button.</p>
Double-Click	<p>Click the mouse button twice in rapid succession.</p>

Contents

Chapter 1. Introduction.....	9
Manual Topics	10
Changes to the Documentation	10
Evaluation Kits and Production Kits.....	11
Types of Users	11
Requesting Assistance.....	12
Software Development Cycle	13
Product Overview	16
Chapter 2. Installation.....	19
System Requirements.....	19
Installation Details	19
Folder Structure	20
Chapter 3. Development Tools.....	21
μ Vision2 Integrated Development Environment	21
C51 Optimizing C Cross Compiler	32
A51 Macro Assembler.....	49
BL51 Code Banking Linker/Locator	51
LIB51 Library Manager.....	54
OC51 Banked Object File Converter	55
OH51 Object-Hex Converter	55
Chapter 4. Creating Applications.....	57
Creating Projects.....	57
Project Targets and File Groups	64
Overview of Configuration Dialogs.....	66
Code Banking	67
μ Vision2 Utilities.....	69
Writing Optimum Code	78
Tips and Tricks	82
Chapter 5. Testing Programs.....	93
μ Vision2 Debugger.....	93
Debug Commands.....	107
Expressions.....	110
Tips and Tricks	126
Chapter 6. μVision2 Debug Functions	131
Creating Functions	131
Invoking Functions	133
Function Classes	133
Differences Between Debug Functions and C.....	147
Differences Between dScope and the μ Vision2 Debugger	148

Chapter 7. Sample Programs.....	149
HELLO: Your First 8051 C Program.....	150
MEASURE: A Remote Measurement System	155
Chapter 8. RTX-51 Real-Time Operating System.....	169
Introduction.....	169
RTX51 Technical Data	173
Overview of RTX51 Routines.....	174
TRAFFIC: RTX-51 Tiny Example Program.....	176
RTX Kernel Aware Debugging.....	180
Chapter 9. Using On-chip Peripherals.....	183
Special Function Registers	183
Register Banks	184
Interrupt Service Routines.....	185
Interrupt Enable Registers.....	187
Parallel Port I/O	187
Timers/Counters.....	189
Serial Interface	190
Watchdog Timer	193
D/A Converter.....	194
A/D Converter.....	195
Power Reduction Modes	196
Chapter 10. CPU and C Startup Code.....	197
Chapter 11. Using Monitor-51	199
Caveats.....	199
Hardware and Software Requirements	200
Serial Transmission Line.....	201
μ Vision2 Monitor Driver	201
μ Vision2 Restrictions when using Monitor-51	202
Tool Configuration when Using Monitor-51.....	204
Monitor-51 Configuration.....	206
Troubleshooting	208
Debugging with Monitor-51.....	209
Chapter 12. Command Reference	211
μ Vision 2 Command Line Invocation.....	211
A51 / A251 Macro Assembler Directives	212
C51/C251 Compiler	213
L51/BL51 Linker/Locator.....	215
L251 Linker/Locator.....	216
LIB51 / L251 Library Manager Commands.....	218
OC51 Banked Object File Converter	219
OH51 Object-Hex Converter	219
OH251 Object-Hex Converter	219

Index.....222

Chapter 1. Introduction

1

Thank you for allowing Keil Software to provide you with software development tools for the 8051 family of microprocessors. With the Keil tools, you can generate embedded applications for virtually every 8051 derivative.

NOTE

*Throughout this manual we refer to these tools as the **8051** development tools. However, they support all derivatives and variants of the 8051 microcontroller family.*

The Keil Software 8051 development tools listed below are programs you use to compile your C code, assemble your assembly source files, link and locate object modules and libraries, create HEX files, and debug your target program. Each of these programs is described in more detail in “Chapter 3. Development Tools” which begins on page 21.

- μ Vision2 for Windows™ is an Integrated Development Environment that combines project management, source code editing, and program debugging in one single, powerful environment.
- The C51 ANSI Optimizing C Cross Compiler creates relocatable object modules from your C source code.
- The A51 Macro Assembler creates relocatable object modules from your 8051 assembly source code.
- The BL51 Linker/Locator combines relocatable object modules created by the C51 Compiler and the A51 Assembler into absolute object modules.
- The LIB51 Library Manager combines object modules into libraries that may be used by the linker.
- The OH51 Object-HEX Converter creates Intel HEX files from absolute object modules.
- The RTX-51 Real-time Operating System simplifies the design of complex, time-critical software projects.

The tools are combined into the kits described in “Product Overview” on page 16. They are designed for the professional software developer, but any level of programmer can use them to get the most out of the 8051 microcontroller architecture.

1

Manual Topics

This manual discusses a number of topics including:

- How to select the best tool kit for your application (see “Product Overview” on page 16),
- How to install the software on your system (see “Chapter 2. Installation” on page 19),
- The features of the 8051 development tools (see “Chapter 3. Development Tools” on page 21),
- How to create complete applications using the μ Vision2 IDE (see “Chapter 4. Creating Applications” on page 57),
- How to debug programs and simulate target hardware with the μ Vision2 debugger (see “Chapter 5. Testing Programs” on page 93),
- How to access the on-chip peripherals and special features of the 8051 variants using the C51 Compiler (see “On-chip Peripheral Symbols” on page 114),
- How to run the sample programs (see “Chapter 7. Sample Programs” on page 149).

NOTE

To get started immediately, install the software (refer to “Chapter 2. Installation” on page 19) and run the sample programs (refer to “Chapter 7. Sample Programs” on page 149).

Changes to the Documentation

Last minute changes and corrections to the software and manuals are listed in the **RELEASE.TXT** files. These files are located in the **\KEIL\UV2** and **\KEIL\C51\HLP** folders. Take the time to read these files to determine if there are changes that may impact your installation.

Evaluation Kits and Production Kits

1

Keil Software delivers software in two types of kits: evaluation kits and production kits.

Evaluation Kits include evaluation versions of our 8051 tools along with this user's guide. The tools in the evaluation kit let you generate applications up to 2 Kbytes in size. This kit allows you to evaluate the effectiveness of our 8051 tools and generate small target applications.

Production Kits (discussed in "Product Overview" on page 16) include the unlimited versions of our 8051 tools along with a full manual set (including this user's guide). The production kits include 1 year of free technical support and product updates. Updates are available at www.keil.com.

Types of Users

This manual addresses three types of users: evaluation users, new users, and experienced users.

Evaluation Users are those users who have not yet purchased the software but have requested the evaluation package to get a better feel for what the tools do and how they perform. The evaluation package includes tools that are limited to 2 Kbytes along with several sample programs that provide applications created for the 8051 microcontroller family. Even if you are only an evaluation user, take the time to read this manual. It explains how to install the software, provides you with an overview of the development tools, and introduces the sample programs.

New Users are those users who are purchasing 8051 development tools for the first time. The included software provides you with the latest development tool technology, manuals, and sample programs. If you are new to the 8051 or the tools, take the time to review the sample programs described in this manual. They provide a quick tutorial and help new or inexperienced users get started quickly.

Experienced Users are those users who have previously used the Keil 8051 development tools and are now upgrading to the latest version. The software included with a product upgrade contains the latest development tools and sample programs.

1

Requesting Assistance

At Keil Software, we are dedicated to providing you with the best embedded development tools and documentation available. If you have suggestions or comments regarding any of the printed manuals accompanying this product, please contact us. If you think you have discovered a problem with the software, do the following before calling technical support.

1. Read the sections in this manual that pertains to the job or task you are trying to accomplish.
2. Make sure you are using the most current version of the software and utilities. Check the update section at **www.keil.com** to make sure that you have the latest software version.
3. Isolate the problem to determine if it is a problem with the assembler, compiler, linker, library manager, or another development tool.
4. Further isolate software problems by reducing your code to a few lines.

If you are still experiencing problems after following these steps, report them to our technical support group. Please include your product serial number and version number. We prefer that you send the problem via email. If you contact us by fax, be sure to include your name and telephone numbers (voice and fax) where we can reach you.

Try to be as detailed as possible when describing the problem you are having. The more descriptive your example, the faster we can find a solution. If you have a single-page code example demonstrating the problem, please email it to us. If possible, make sure that your problem can be duplicated with the μ Vision2 simulator. Please try to avoid sending complete applications or long listings as this slows down our response to you.

NOTE

*You can always get technical support, product updates, application notes, and sample programs from **www.keil.com/support**.*

Software Development Cycle

When you use the Keil Software tools, the project development cycle is roughly the same as it is for any other software development project.

1. Create a project, select the target chip from the device database, and configure the tool settings.
2. Create source files in C or assembly.
3. Build your application with the project manager.
4. Correct errors in source files.
5. Test the linked application.

A block diagram of the complete 8051 tool set may best illustrate the development cycle. Each component is described below.

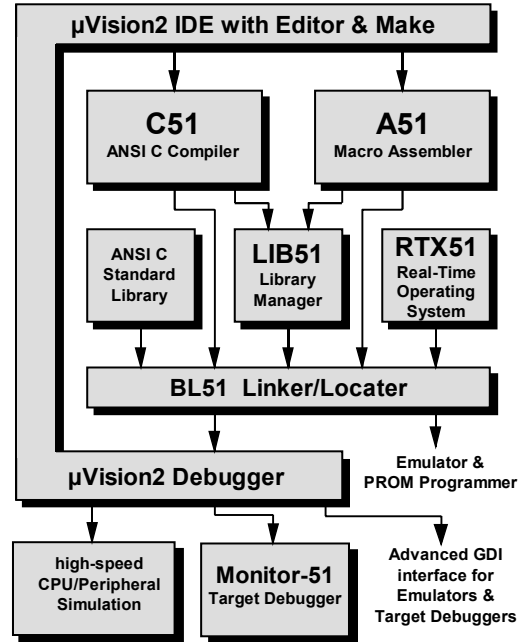

µVision2 IDE

The µVision2 IDE combines project management, a rich-featured editor with interactive error correction, option setup, make facility, and on-line help.

Use µVision2 to create your source files and organize them into a project that defines your target application. µVision2 automatically compiles, assembles, and links your embedded application and provides a single focal point for your development efforts.

C51 Compiler & A51 Assembler

Source files are created by the μ Vision2 IDE and are passed to the C51 Compiler or A51 assembler. The compiler and assembler process source files and create relocatable object files.

The Keil C51 Compiler is a full ANSI implementation of the C programming language that supports all standard features of the C language. In addition, numerous features for direct support of the 8051 architecture have been added.

The Keil A51 macro assembler supports the complete instruction set of the 8051 and all derivatives.

LIB51 Library Manager

The LIB51 library manager allows you to create object library from the object files created by the compiler and assembler. Libraries are specially formatted, ordered program collections of object modules that may be used by the linker at a later time. When the linker processes a library, only those object modules in the library that are necessary to create the program are used.

BL51 Linker/Locator

The BL51 linker creates an absolute object module using the object modules extracted from libraries and those created by the compiler and assembler. An absolute object file or module contains no relocatable code or data. All code and data reside at fixed memory locations. The absolute object file may be used:

- To program an EPROM or other memory devices,
- With the μ Vision2 Debugger for simulation and target debugging,
- With an in-circuit emulator for the program testing.

μVision2 Debugger

The μVision2 symbolic, source-level debugger is ideally suited for fast, reliable program debugging. The debugger includes a high-speed simulator that let you simulate an entire 8051 system including on-chip peripherals and external hardware. The attributes of the chip you use are automatically configured when you select the device from the Device Database.

The μVision2 Debugger provides several ways for you to test your programs on real target hardware.

- Install the MON51 Target Monitor on your target system and download your program using the Monitor-51 interface built-in to the μVision2 Debugger.
- Use the *Advanced GDI* interface to attach use the μVision2 Debugger front end with your target system.

Monitor-51

The μVision2 Debugger supports target debugging using Monitor-51. The monitor program resides in the memory of your target hardware and communicates with the μVision2 Debugger using the serial port of the 8051 and a COM port of your PC. With Monitor-51, μVision2 lets you perform source-level, symbolic debugging on your target hardware.

RTX51 Real-Time Operating System

The RTX51 real-time operating system is a multitasking kernel for the 8051 microcontroller family. The RTX51 real-time kernel simplifies the system design, programming, and debugging of complex applications where fast reaction to time critical events is essential. The kernel is fully integrated into the C51 Compiler and is easy to use. Task description tables and operating system consistency are automatically controlled by the BL51 linker/locator.

1

Product Overview

Keil Software provides the premier development tools for the 8051 family of microcontrollers. We bundle our software development tools into different packages or tool kits. The “Comparison Chart” on page 17 shows the full extent of the Keil Software 8051 development tools. Each kit and its contents are described below.

PK51 Professional Developer’s Kit

The **PK51** Professional Developer’s Kit includes everything the professional developer needs to create and debug sophisticated embedded applications for the 8051 family of microcontrollers. The professional developer’s kit can be configured for all 8051 derivatives.

DK51 Developer’s Kit

The **DK51** Developer’s Kit is a reduced version of PK51 and does not include the RTX51 Tiny real-time operating system. The developer’s kit can be configured for all 8051 derivatives.

CA51 Compiler Kit

The **CA51** Compiler Kit is the best choice for developers who need a C compiler but not a debugging system. The CA51 package contains only the μ Vision2 IDE. The μ Vision2 Debugger features are not available in CA51. The kit includes everything you need to create embedded applications and can be configured for all 8051 derivatives.

A51 Assembler Kit

The A51 Assembler Kit includes an assembler and all the utilities you need to create embedded applications. It can be configured for all 8051 derivatives.

RTX51 Real-Time Operating System (FR51)

The RTX51 Real-Time Operating Systems is a real-time kernel for the 8051 family of microcontrollers. RTX51 Full provides a superset of the features found in RTX51 Tiny and includes CAN communication protocol interface routines.

Comparison Chart

The following table provides a checklist of the features found in each package. Tools are listed along the top and part numbers for specific kits are listed along the side. Use this cross-reference to select the kit that best suits your needs.

Components	PK51	DK51 [†]	CA51	A51	FR51
µVision2 Project Management & Editor	✓	✓	✓	✓	
A51 Assembler	✓	✓	✓	✓	
C51 Compiler	✓	✓	✓		
BL51 Linker/Locator	✓	✓	✓	✓	
LIB51 Library Manager	✓	✓	✓	✓	
µVision2 Debugger/Simulator	✓	✓			
RTX51 Tiny	✓				
RTX51 Full					✓

1

Chapter 2. Installation

This chapter explains how to setup an operating environment and how to install the software on your hard disk. Before starting the installation program:

- Verify that your computer system meets the minimum requirements,
- Make a copy of the installation diskette for backup purposes.

2

System Requirements

There are minimum hardware and software requirements that must be satisfied to ensure that the compiler and utilities function properly. You must have:

- PC with Pentium, Pentium-II or compatible processor,
- Windows 95, Windows-98, Windows NT 4.0, or higher,
- 16 MB RAM minimum,
- 20 MB free disk space.

Installation Details

All Keil products come with an installation program that allows easy installation. To install the 8051 development tools:

- Insert the Keil Development Tools CD-ROM,
- Select **Install Software** from the CD Viewer menu,
- Follow the instructions displayed by the setup program.

NOTE

Your PC should automatically launch the CD Viewer when you insert the CD. If not, run \KEIL\SETUP\SETUP.EXE from the CD to install the software.

Folder Structure

The setup program copies the development tools into sub-folders of the base folder. The default base folder is: **C:\KEIL**. The following table lists the structure of a complete installation that includes the entire line of 8051 development tools. Your installation may vary depending on the products you purchased.

Folder	Description
C:\KEIL\C51\ASM	Assembler SFR definition files and template source file.
C:\KEIL\C51\BIN	Executable files of the 8051 tool chain.
C:\KEIL\C51\EXAMPLES	Sample applications.
C:\KEIL\C51\RTX51	RTX51 Full files.
C:\KEIL\C51\RTX_TINY	RTX51 Tiny files.
C:\KEIL\C51\INC	C compiler include files.
C:\KEIL\C51\LIB	C compiler library files, startup code, and source of I/O routines.
C:\KEIL\C51\MONITOR	Target Monitor files and Monitor configuration for user hardware.
C:\KEIL\UV2	Generic μ Vision2 files.

In this users guide, we refer to the default folder structure. If you install your software in a different folder, you must adjust the pathnames to match your installation.

Chapter 3. Development Tools

The Keil development tools for the 8051 offer numerous features and advantages that help you quickly and successfully develop embedded applications. They are easy to use and are guaranteed to help you achieve your design goals.

μ Vision2 Integrated Development Environment

The μ Vision2 IDE is a Windows-based software development platform that combines a robust editor, project manager, and make facility. μ Vision2 supports all of the Keil tools for the 8051 including the C compiler, macro assembler, linker/locator, and object-HEX converter. μ Vision2 helps expedite the development process of your embedded applications by providing the following:

- Full-featured source code editor,
- Device database for configuring the development tool setting,
- Project manager for creating and maintaining your projects,
- Integrated make facility for assembling, compiling, and linking your embedded applications,
- Dialogs for all development tool settings,
- True integrated source-level Debugger with high-speed CPU and peripheral simulator,
- Advanced GDI interface for software debugging in the target hardware and for connection to Monitor-51,
- Links to development tools manuals, device datasheets & user's guides.

NOTE

*The μ Vision2 debugging features are only available in the **PK51** and **DK51** kits.*

About the Environment



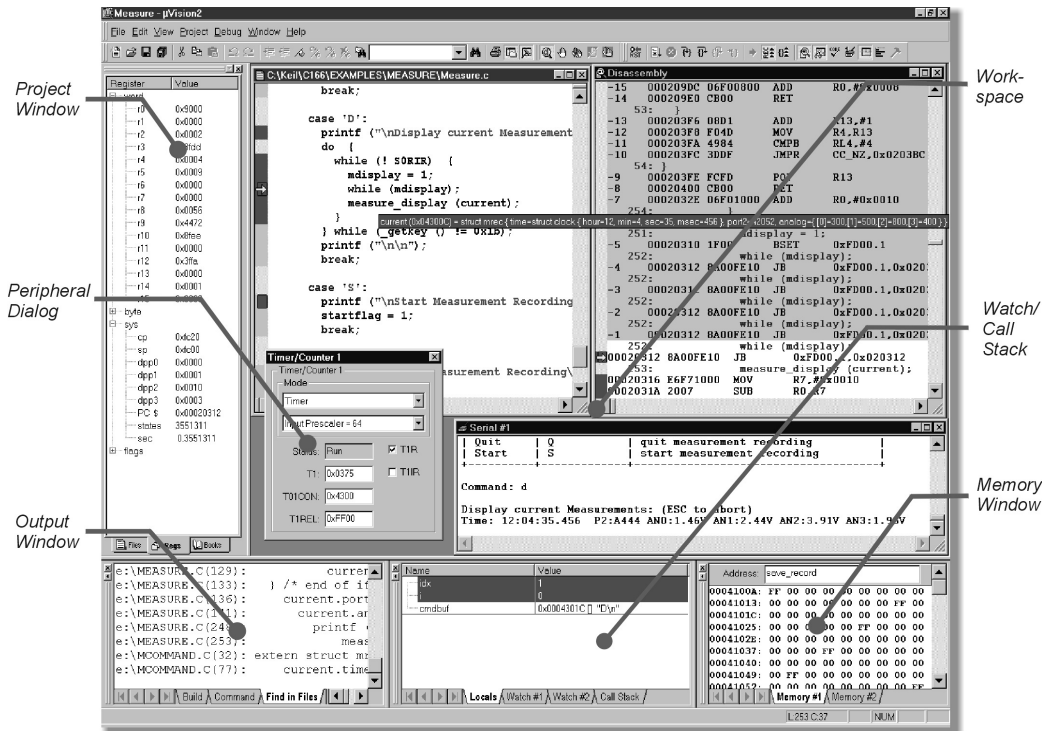

The μ Vision2 screen provides you with a menu bar for command entry, a tool bar where you can rapidly select command buttons, and windows for source files, dialog boxes, and information displays. μ Vision2 lets you simultaneously open and view multiple source files.















Menu Commands, Toolbars, and Shortcuts

The menu bar provides you with menus for editor operations, project maintenance, development tool option settings, program debugging, window selection and manipulation, and on-line help. The toolbar buttons allow you to rapidly execute μ Vision2 commands. Keyboard shortcuts (that you may configure) allow you to execute μ Vision2 commands. The following tables list the μ Vision2 menu items and commands, the toolbar icons, default shortcuts, and descriptions.

File Menu and File Commands

File Menu	Toolbar	Shortcut	Description
New		Ctrl+N	Create a new source or text file
Open		Ctrl+O	Open an existing file
Close			Close the active file
Save		Ctrl+S	Create a new source or text file
			Save all open source and text files
Save as...			Save and rename the active file
Device Database			Maintain the μ Vision2 device database
Print Setup...			Setup the printer
Print		Ctrl+P	Print the active file
Print Preview			Display pages in print view
1-9			Open the most recent used source or text files
Exit			Quit μ Vision2 and prompt for saving files

Edit Menu and Editor Commands

Edit Menu	Toolbar	Shortcut	Description
		Home	Move cursor to beginning of line
		End	Move cursor to end of line
		Ctrl+Home	Move cursor to beginning of file
		Ctrl+End	Move cursor to end of file
		Ctrl+←	Move cursor one word left
		Ctrl+→	Move cursor one word right
		Ctrl+A	Select all text in the current file
Undo		Ctrl+Z	Undo last operation
Redo		Ctrl+Shift+Z	Redo last undo command
Cut		Ctrl+X	Cut selected text to clipboard
		Ctrl+Y	Cut text in the current line to clipboard
Copy		Ctrl+C	Copy selected text to clipboard
Paste		Ctrl+V	Paste text from clipboard
Indent			
Selected Text			Indent selected text right one tab stop
Unindent			
Selected Text			Indent selected text left one tab stop
Toggle Bookmark		Ctrl+F2	Toggle bookmark at current line
Goto Next Bookmark		F2	Move cursor to next bookmark
Goto Previous Bookmark		Shift+F2	Move cursor to previous bookmark
Clear All Bookmarks			Clear all bookmarks in active file
Find		Ctrl+F	Search text in the active file
		F3	Repeat search text forward
		Shift+F3	Repeat search text backward
		Ctrl+F3	Search word under cursor
		Ctrl+]]	Find matching brace, parenthesis, or bracket (to use this command place cursor before a brace, parenthesis, or bracket)
Replace		Ctrl+H	Replace specific text
Find in Files...			Search text in several files











Selecting Text Commands

In μ Vision2, you may select text by holding down **Shift** and pressing the appropriate cursor key. For example, **Ctrl+→** moves the cursor to the next word while **Ctrl+Shift+→** selects the text from the current cursor position to the beginning of the next word.







You may also use the mouse to select text.

To Select...	With the Mouse...
Any amount of text	Drag over the text
A word	Double-click the word
A line of text	Move the pointer to the left of the line until it changes to a right-pointing arrow and click
Multiple lines of text	Move the pointer to the left of the lines until it changes to a right-pointing arrow and drag up or down
A vertical block of text	Hold down Alt and drag













View Menu

View Menu	Toolbar	Shortcut	Description
Status Bar			Show or hide the status bar
File Toolbar			Show or hide the File toolbar
Build Toolbar			Show or hide the Build toolbar
Debug Toolbar			Show or hide the Debug toolbar
Project Window			Show or hide the Project window
Output Window			Show or hide the Output window
Source Browser			Open the Source Browser window
Disassembly Window			Show or hide the Disassembly window
Watch & Call Stack Window			Show or hide the Watch & Call Stack window
Memory Window			Show or hide the Memory window
Code Coverage Window			Show or hide the Code Coverage window
Performance Analyzer Window			Show or hide the Performance Analyzer window
Symbol Window			Show or hide the Symbol window
Serial Window #1			Show or hide the Serial window #1
Serial Window #2			Show or hide the Serial window #2
Toolbox			Show or hide the Toolbox
Periodic Window Update			Updates debug windows while running the program
Workbook Mode			Show workbook frame with windows tabs
Options...			Change Colors, Fonts, Shortcuts and Editor options

Project Menu and Project Commands

Project Menu	Toolbar	Shortcut	Description
New Project ...			Create a new project
Import µVision1 Project ...			Convert a µVision1 Project File (see page 82)
Open Project ...			Open an existing project
Close Project...			Close current project
Target Environment			Define paths for tool chain, include & library files
Targets, Groups, Files			Maintain Targets, File Groups and Files of a project
Select Device for Target			Select a CPU from the Device Database
Remove...			Remove a Group or File from the project
Options...		Alt+F7	Change tool options for Target, Group or File Change options for current Target
			Select current Target
File Extensions			Select file extensions for different file types
Build Target		F7	Translate modified files and build application
Rebuild Target			Re-translate all source files and build application
Translate...		Ctrl+F7	Translate current file
Stop Build			Stop current build process
1-9			Open the most recent used project files

Debug Menu and Debug Commands

Debug Menu	Toolbar	Shortcut	Description
Start/Stop Debugging		Ctrl+F5	Start or stop μ Vision2 Debug Mode
Go		F5	Run (execute) until the next active breakpoint
Step		F11	Execute a single-step into a function
Step over		F10	Execute a single-step over a function
Step out of current function		Ctrl+F11	Execute a step out of the current function
Stop Running		ESC	Stop program execution
Breakpoints...			Open Breakpoint dialog
Insert/Remove Breakpoint			Toggle breakpoint on current line
Enable/Disable Breakpoint			Enable/disable breakpoint on the current line
Disable All Breakpoints			Disable all breakpoints in the program
Kill All Breakpoints			Kill all breakpoints in the program
Show Next Statement			Show next executable statement/instruction
Enable/Disable Trace Recording			Enable trace recording for instruction review
View Trace Records			Review previous executed instructions
Memory Map...			Open memory map dialog
Performance Analyzer...			Open setup dialog for the Performance Analyzer
Inline Assembly...			Stop current build process
Function Editor...			Edit debug functions and debug INI file

Peripherals Menu

Peripherals Menu	Toolbar	Shortcut	Description
Reset CPU			Set CPU to reset state
Interrupt, I/O-Ports, Serial, Timer, A/D Converter, D/A Converter, I ² C Controller, CAN Controller, Watchdog			Open dialogs for on-chip peripherals, these dialogs depend on the CPU selected from the device database. This list will vary by microcontroller.

3

Tools Menu

The tools menu allows you to configure and run Gimpel PC-Lint, Siemens Easy-Case, and custom programs. With **Customize Tools Menu...** user programs are added to the menu. For more information refer to “Using the Tools Menu” on page 72.

Tools Menu	Toolbar	Shortcut	Description
Setup PC-Lint...			Configure PC-Lint from Gimpel Software
Lint			Run PC-Lint current editor file
Lint all C Source Files			Run PC-Lint across the C source files of your project
Setup Easy-Case...			Configure Siemens Easy-Case
Start/Stop Easy-Case			Start or stop Siemens Easy-Case
Show File (Line)			Open Easy-Case with the current editor file
Customize Tools Menu...			Add user programs to the Tools Menu

SVCS Menu

With the SVCS menu you configure and add the commands of a Software Version Control System (SVCS). For more information refer to “Using the SVCS Menu” on page 76.

SVCS Menu	Toolbar	Shortcut	Description
Configure Version Control...			Configure the commands of your SVCS

3

Window Menu

Window Menu	Toolbar	Shortcut	Description
Cascade			Arrange Windows so they overlap
Tile Horizontally			Arrange Windows so they no overlap
Tile Vertically			Arrange Windows so they no overlap
Arrange Icons			Arrange Icons at the bottom of the window
Split			Split the active window into panes
1-9			Activate the selected window

Help Menu

Help Menu	Toolbar	Shortcut	Description
Help topics			Open on-line help
About μ Vision			Display version numbers and license information

μ Vision2 has two operating modes:

- **Build Mode:** Allows you to translate all the application files and to generate executable programs. The features of the Build Mode are described in "Chapter 4. Creating Applications" on page 57.
- **Debug Mode:** Provides you with a powerful debugger for testing your application. The Debug Mode is described in "Chapter 5. Testing Programs" on page 93.

In both operating modes you may use the source editor of μ Vision2 to modify your source code.

C51 Optimizing C Cross Compiler

The Keil C51 Cross Compiler is an ANSI C Compiler that was written specifically to generate fast, compact code for the 8051 microcontroller family. The C51 Compiler generates object code that matches the efficiency and speed of assembly programming.

Using a high-level language like C has many advantages over assembly language programming:

- Knowledge of the processor instruction set is not required. Rudimentary knowledge of the memory structure of the 8051 CPU is desirable (but not necessary).
- Details like register allocation and addressing of the various memory types and data types is managed by the compiler.
- Programs get a formal structure (which is imposed by the C programming language) and can be divided into separate functions. This contributes to source code reusability as well as better overall application structure.
- The ability to combine variable selection with specific operations improves program readability.
- Keywords and operational functions that more nearly resemble the human thought process may be used.
- Programming and program test time is drastically reduced.
- The C run-time library contains many standard routines such as: formatted output, numeric conversions, and floating-point arithmetic.
- Existing program parts can be more easily included into new programs because of modular program construction techniques.
- The language C is a very portable language (based on the ANSI standard) that enjoys wide popular support and is easily obtained for most systems. Existing program investments can be quickly adapted to other processors as needed.

C51 Language Extensions

Even though the C51 Compiler is ANSI-compliant, some extensions were added to support the facilities of the 8051 microprocessor. The C51 Compiler includes extensions for:

- Data Types,
- Memory Types,
- Memory Models,
- Pointers,
- Reentrant Functions,
- Interrupt Functions,
- Real-Time Operating Systems,
- Interfacing to PL/M and A51 source files.

The following sections briefly describe these extensions.

Data Types

The C51 Compiler supports the scalar data types listed in the following table. In addition to these scalar types, variables may be combined into structures, unions, and arrays. Except as noted, you may use pointers to access these data types.

Data Type	Bits	Bytes	Value Range
bit †	1		0 to 1
signed char	8	1	-128 to +127
unsigned char	8	1	0 to 255
enum	16	2	-32768 to +32767
signed short	16	2	-32768 to +32767
unsigned short	16	2	0 to 65535
signed int	16	2	-32768 to +32767
unsigned int	16	2	0 to 65535
signed long	32	4	-2147483648 to 2147483647
unsigned long	32	4	0 to 4294967295
float	32	4	$\pm 1.175494\text{E}-38$ to $\pm 3.402823\text{E}+38$
sbit †	1		0 to 1
sfr †	8	1	0 to 255
sfr16 †	16	2	0 to 65535

† **bit**, **sbit**, **sfr**, and **sfr16** specific to the 8051 hardware and the C51 and C251 compilers. They are not a part of ANSI C and cannot be accessed through pointers.

The **sbit**, **sfr**, and **sfr16** data types allow you to access the special function registers that are available on the 8051. For example, the declaration:

```
sfr P0 = 0x80; /* Define 8051 P0 SFR */
```

declares the variable **p0** and assigns it the special function register address of **0x80**. This is the address of PORT 0 on the 8051.

The C51 Compiler automatically converts between data types when the result implies a different type. For example, a bit variable used in an integer assignment is converted to an integer. You can, of course, coerce a conversion by using a type cast. In addition to data type conversions, sign extensions are automatically carried out for signed variables.

3

Memory Types

The C51 Compiler supports the architecture of the 8051 and its derivatives and provides access to all memory areas of the 8051. Each variable may be explicitly assigned to a specific memory space using the memory types listed in the following table.

Memory Type	Description
code	Program memory (64 Kbytes); accessed by opcode MOVC @A+DPTR .
data	Directly addressable internal data memory; fastest access (128 bytes).
idata	Indirectly addressable internal data memory; accessed across the full internal address space (256 bytes).
bdata	Bit-addressable internal data memory; mixed bit and byte access (16 bytes).
xdata	External data memory (64 Kbytes); accessed by opcode MOVX @DPTR .
pdata	Paged (256 bytes) external data memory; accessed by opcode MOVX @Rn .

Accessing the internal data memory is considerably faster than accessing the external data memory. For this reason, you should place frequently used variables in internal data memory and less frequently used variables in external data memory. This is most easily done by using the **SMALL** memory model.

By including a memory type specifier in the variable declaration, you can specify where variables are stored.

As with the **signed** and **unsigned** attributes, you may include memory type specifiers in the variable declaration. For example:

```
char data var1;
char code text[] = "ENTER PARAMETER:";
unsigned long xdata array[100];
float idata x,y,z;
unsigned int pdata dimension;
unsigned char xdata vector[10][4][4];
char bdata flags;
```

If the memory type specifier is omitted in a variable declaration, the default or implicit memory type is automatically selected. The implicit memory type is applied to all global variables and static variables and to function arguments and automatic variables that cannot be located in registers.

The default memory type is determined by the **SMALL**, **COMPACT**, and **LARGE** compiler control directives. These directives specify the memory model to use for the compilation.

3

Memory Models

The memory model determines the default memory type used for function arguments, automatic variables, and variables declared with no explicit memory type. You specify the memory model on the command line using the **SMALL**, **COMPACT**, and **LARGE** control directives. By explicitly declaring a variable with a memory type specifier, you may override the default memory type.

SMALL All variables default to the internal data memory of the 8051. This is the same as if they were declared explicitly using the **data** memory type specifier. In this memory model, variable access is very efficient. However, all data objects, as well as the stack must fit into the internal RAM. Stack size is critical because the stack space used depends on the nesting depth of the various functions. Typically, if the BL51 code banking linker/locator is configured to overlay variables in the internal data memory, the small model is the best model to use.

COMPACT All variables default to one page (256 bytes) of external data memory. The high byte of the address is usually set up via Port 2 which you must set manually in the startup code (the compiler does not set this port for you). Variables in the **COMPACT** memory model appear as if they were explicitly declared using the **pdata** memory type specifier. This memory model can accommodate a maximum of 256 bytes of variables. The limitation is due to the indirect addressing scheme using R0 and R1 (MOVX @R0/@R1). This memory model is not as efficient as the small model, therefore, variable access is not as fast. However, the **COMPACT** model is faster than the **LARGE** model.

LARGE In large model, all variables default to external data memory (**xdata**). This is the same as if they were explicitly declared using the **xdata** memory type specifier. The data pointer (**DPTR**) is used for addressing. Memory access through this data pointer is inefficient, especially for variables with a length of two or more bytes. This type of data access generates more code than the **SMALL** or **COMPACT** models.

NOTE

*You should always use the **SMALL** memory model. It generates the fastest, tightest, and most efficient code. You can always explicitly specify the memory area for variables. Move up in model size only if you are unable to make your application fit or operate using **SMALL** model.*

Pointers

The C51 Compiler supports pointer declarations using the asterisk character (*). You may use pointers to perform all operations available in standard C. However, because of the unique architecture of the 8051 and its derivatives, the C51 Compiler supports two different types of pointers: memory specific pointers and generic pointers.

Generic Pointers

Generic or untyped pointers are declared in the same way as standard C pointers. For example:

```
char *s;           /* string ptr */
int *numptr;      /* int ptr */
long *state;      /* long ptr */
```

Generic pointers are always stored using three bytes. The first byte is for the memory type, the second is for the high-order byte of the offset, and the third is for the low-order byte of the offset.

Generic pointers may be used to access any variable regardless of its location in 8051 memory space. Many of the library routines use these pointer types for this reason. By using these generic untyped pointers, a function can access data regardless of the memory in which it is stored.

Generic pointers are convenient, however, they are also slow. They are best used when the memory space of the object pointed to is uncertain.

Memory Specific Pointers

Memory specific or typed pointers include a memory type specification in the pointer declaration and always refer to a specific memory area. For example:

```
char data *str;           /* ptr to string in data */
int xdata *numtab;      /* ptr to int(s) in xdata */
long code *powtab;     /* ptr to long(s) in code */
```

Because the memory type is specified at compile-time, the memory type byte required by generic pointers is not required. Memory-specific pointers are stored using one byte (for **idata**, **data**, **bdata**, and **pdata** pointers) or two bytes (for **code** and **xdata** pointers).

3

Memory-specific pointers are more efficient and faster to use than generic pointers. However, they are non-portable. They are best used when the memory space of the object pointed to is certain and does not change.

Comparison: Memory Specific & Generic Pointers

You can significantly accelerate an 8051 C program by using memory specific pointers. The following sample program shows the differences in code & data size and execution time for various pointer declarations.

Description	Idata Pointer	Xdata Pointer	Generic Pointer
Sample Program	char idata *ip; char val; val = *ip;	char xdata *xp; char val; val = *xp;	char *p; char val; val = *p;
8051 Program Code Generated	MOV R0,ip MOV val,@R0	MOV DPL,xp +1 MOV DPH,xp MOV A,@DPTR MOV val,A	MOV R1,p + 2 MOV R2,p + 1 MOV R3,p CALL CLDPTR
Pointer Size	1 byte	2 bytes	3 bytes
Code Size	4 bytes	9 bytes	11 bytes + library call
Execution Time	4 cycles	7 cycles	13 cycles

Reentrant Functions

Several processes may share a reentrant function at the same time. When a reentrant function is executing, another process can interrupt the execution and then begin to execute that same reentrant function. Normally, C51 functions may not be called recursively or in a fashion which causes reentrancy. The reason for this limitation is that function arguments and local variables are stored in fixed memory locations. The **reentrant** function attribute allows you to declare functions that may be reentrant and, therefore, may be called recursively. For example:

```
int calc (char i, int b) reentrant
{
    int x;
    x = table [i];
    return (x * b);
}
```

Reentrant functions may be called recursively and may be called *simultaneously* by two or more processes. Reentrant functions are often required in real-time applications or in situations where interrupt code and non-interrupt code must share a function.

For each reentrant function, a reentrant stack area is simulated in internal or external memory depending on the memory model.

NOTE

*Use the **reentrant** attribute on a function by function basis. This way, you can select only those functions that must be reentrant without making the entire program **reentrant**. Making an entire program reentrant will result in larger code size and slower execution speed.*

Interrupt Functions

The C51 Compiler allows you to create interrupt service routines in C. You need only be concerned with the interrupt number and register bank selection. The compiler automatically generates the interrupt vector as well as entry and exit code for the interrupt routine. The **interrupt** function attribute, when included in a declaration, specifies that the associated function is an interrupt function. Additionally, you can specify the register bank used for that interrupt with the **using** function attribute.

```

unsigned int interruptcnt;
unsigned char second;

void timer0 (void) interrupt 1 using 2 {
    if (++interruptcnt == 4000) {
        second++;
        interruptcnt = 0;
    }
}
/* count to 4000 */
/* second counter */
/* clear int counter */

```

3

Parameter Passing

The C51 Compiler passes up to three function arguments in CPU registers. This significantly improves system performance since arguments do not have to be written to and read from memory. Argument passing can be controlled with the **REGPARMS** and **NOREGPARMS** control directives. The following table lists the registers used for different arguments and data types.

Argument Number	char, 1-byte pointer	int, 2-byte pointer	long, float	generic pointer
1	R7	R6 & R7	R4 — R7	R1 — R3
2	R5	R4 & R5		
3	R3	R2 & R3		

If no registers are available for argument passing or if too many arguments are involved, fixed memory locations are used for those extra arguments.

Function Return Values

CPU registers are always used for function return values. The following table lists the return types and the registers used for each.

Return Type	Register	Description
bit	Carry Flag	
char, unsigned char, 1-byte pointer	R7	
int, unsigned int, 2-byte pointer	R6 & R7	MSB in R6, LSB in R7
long, unsigned long	R4 — R7	MSB in R4, LSB in R7
float	R4 — R7	32-Bit IEEE format
generic pointer	R1 — R3	Memory type in R3, MSB R2, LSB R1

Register Optimizing

Depending on program context, the C51 Compiler allocates up to 7 CPU registers for register variables. Registers modified during function execution are noted by the C51 Compiler within each module. The linker/locator generates a global, project-wide register file that contains information about all registers that are altered by external functions. Consequently, the C51 Compiler *knows* the register used by each function in an application and can optimize the CPU register allocation of each C function.

Real-Time Operating System Support

The C51 Compiler integrates well with both the RTX-51 Full and RTX-51 Tiny multitasking real-time operating systems. The task description tables are generated and controlled during the link process. For more information about the RTX real-time operating systems, refer to “Chapter 8. RTX-51 Real-Time Operating System” on page 169.

Interfacing to Assembly

You can easily access assembly routines from C and vice versa. Function parameters are passed via CPU registers or, if the **NOREGPARMS** control is used, via fixed memory locations. Values returned from functions are always passed in CPU registers.

You may use the **SRC** directive to direct the C51 Compiler to generate an assembly source file (ready to assemble with the A51 assembler) instead of an object file. For example, the following C source file:

```
unsigned int asmfunc1 (unsigned int arg){
    return (1 + arg);
}
```

generates the following assembly output file when compiled using the **SRC** directive.

```
?PR?_asmfunc1?ASML      SEGMENT CODE
PUBLIC                  _asmfunc1
                        RSEG ?PR?_asmfunc1?ASML
                        USING 0

_asmfunc1:
;---- Variable 'arg?00' assigned to Register 'R6/R7' ----
                        MOV  A,R7          ; load LSB of the int
                        ADD  A,#01H        ; add 1
                        MOV  R7,A          ; put it back into R7
                        CLR  A
                        ADDC A,R6         ; add carry & R6
                        MOV  R6,A

?C0001:
                        RET                ; return result in R6/R7
```

You may use the **#pragma asm** and **#pragma endasm** preprocessor directives to insert assembly instructions into your C source code.

Interfacing to PL/M-51

Intel's PL/M-51 is a popular programming language that is similar to C in many ways. You can easily interface routines written in C to routines written in PL/M-51. You can access PL/M-51 functions from C by declaring them with the **alien** function type specifier. All public variables declared in the PL/M-51 module are available to your C programs. For example:

```
extern alien char plm_func (int, char);
```

The PL/M-51 compiler and the Keil Software tools all generate object files in the OMF51 format. The linker uses the OMF51 files to resolve external symbols no matter where they are declared or used.

3

Code Optimizations

The C51 Compiler is an aggressive optimizing compiler that takes numerous steps to ensure that the code generated and output to the object file is the most efficient (smallest and/or fastest) code possible. The compiler analyzes the generated code to produce the most efficient instruction sequences. This ensures that your C program runs as quickly and effectively as possible in the least amount of code space.

The C51 Compiler provides nine different levels of optimizing. Each increasing level includes the optimizations of levels below it. The following is a list of all optimizations currently performed by the C51 Compiler.

General Optimizations

- **Constant Folding:** Constant values occurring in an expression or address calculation are combined as a single constant.
- **Jump Optimizing:** Jumps are inverted or extended to the final target address when the program efficiency is thereby increased.
- **Dead Code Elimination:** Code that cannot be reached (dead code) is removed from the program.
- **Register Variables:** Automatic variables and function arguments are located in registers whenever possible. No data memory space is reserved for these variables.

3

- **Parameter Passing Via Registers:** A maximum of three function arguments may be passed in registers.
- **Global Common Subexpression Elimination:** Identical subexpressions or address calculations that occur multiple times in a function are recognized and calculated only once whenever possible.
- **Common Tail Merging:** Common instruction blocks are merged together using jump instructions.
- **Re-use Common Entry Code:** Common instruction sequences are moved in front of a function to reduce code size.
- **Common Block Subroutines:** Multiple instruction sequences are packed into subroutines. Instructions are rearranged to maximize the block size.

8051-Specific Optimizations

- **Peephole Optimization:** Complex operations are replaced by simplified operations when memory space or execution time can be saved as a result.
- **Access Optimizing:** Constants and variables are computed and included directly in operations.
- **Extended Access Optimizing:** The DPTR register is used as a register variable for memory specific pointers to improve code density.
- **Data Overlaying:** Function data and bit segments are OVERLAYABLE and are overlaid with other data and bit segments by the BL51 linker.
- **Case/Switch Optimizing:** Depending upon their number, sequence, and location, **switch** and **case** statements may be optimized using a jump table or string of jumps.

Options for Code Generation

- **OPTIMIZE(SIZE):** Common C operations are replaced by subprograms. Program code size is reduced at the expense of program speed.
- **OPTIMIZE(SPEED):** Common C operations are expanded in-line. Program speed is increased at the expense of code size.
- **NOAREGS:** Absolute register access is not used. Program code is independent of the register bank.
- **NOREGPARGS:** Parameter passing is performed in local data segments rather than dedicated registers. This is compatible with earlier versions of the C51 Compiler, the PL/M-51 compiler, and the ASM-51 assembler.

Debugging

The C51 Compiler uses the Intel Object Format (OMF51) for object files and generates complete symbol information. Additionally, the compiler can include all the necessary information such as; variable names, function names, line numbers, and so on to allow detailed and thorough debugging and analysis with the μ Vision2 Debugger or any Intel-compatible emulators. In addition, the **OBJECTEXTEND** control directive embeds additional variable type information in the object file that allows type-specific display of variables and structures when using certain emulators. You should check with your emulator vendor to determine if it is compatible with the Intel OMF51 object module format and if it can accept Keil object modules.

3

Library Routines

The C51 Compiler includes seven different ANSI compile-time libraries that are optimized for various functional requirements.

Library File	Description
C51S.LIB	Small model library without floating-point arithmetic
C51FPS.LIB	Small model floating-point arithmetic library
C51C.LIB	Compact model library without floating-point arithmetic
C51FPC.LIB	Compact model floating-point arithmetic library
C51L.LIB	Large model library without floating-point arithmetic
C51FPL.LIB	Large model floating-point arithmetic library
80C751.LIB	Library for use with the Philips 8xC751 and derivatives.

Source code is provided for library modules that perform hardware-related I/O and is found in the `\KEIL\C51\LIB` directory. You may use these source files to help you quickly adapt the library to perform I/O using any I/O device in your target.

Intrinsic Library Routines

The libraries included with the compiler include a number of routines that are implemented as intrinsic functions. Non-intrinsic functions generate **ACALL** or **LCALL** instructions to perform the library routine. The following intrinsic functions generate in-line code that is faster and more efficient than a function call.

Intrinsic Function	Description
<code>_crol_</code>	Rotate character left.
<code>_cror_</code>	Rotate character right.
<code>_irol_</code>	Rotate integer left.
<code>_iror_</code>	Rotate integer right.
<code>_lrol_</code>	Rotate long integer left.
<code>_lror_</code>	Rotate long integer right.
<code>_nop_</code>	No operation (8051 NOP instruction).
<code>_testbit_</code>	Test and clear bit (8051 JBC instruction).

3

Program Invocation

Typically, the C51 Compiler is called from the μ Vision2 IDE when you build your project. However, you may invoke the compiler in a DOS box by typing C51 on the command line. The name of the C source file to compile must be specified on the command line along with any compiler directives. For example:

```
>C51 MODULE.C COMPACT PRINT (E:M.LST) DEBUG SYMBOLS
C51 COMPILER V6.00

C51 COMPILATION COMPLETE.  0 WARNING(S), 0 ERROR(S)
```

Compiler control directives may be entered on the command line or via the *#pragma* directive at the beginning of the C source file. For a complete list of the available compiler directives refer to “C51/C251 Compiler” on page 213.

Sample Program

The following example shows some functional capabilities of the C51 Compiler. The compiler produces object files in OMF51 format in response to the various C language statements and compiler directives.

The compiler emits all necessary information such as variable names, function names, line numbers, and so on to allow detailed program debugging and analysis with the μ Vision2 Debugger or an emulator.

After compiling, the C51 Compiler produces a listing file that contains source code, directive information, an assembly listing, and a symbol table. An example listing file created by the C51 Compiler is shown on the following page.

C51 COMPILER V6.00, SAMPLE 01/01/2001 08:00:00 PAGE 1

DOS C51 COMPILER V6.00, COMPILATION OF MODULE SAMPLE
 OBJECT MODULE PLACED IN SAMPLE.OBJ
 COMPILER INVOKED BY: C:\KEIL\C51\BIN\C51.EXE SAMPLE.C CODE

```

stmt level source
 1      #include <reg51.h> /* SFR definitions for 8051 */
 2      #include <stdio.h> /* standard i/o definitions */
 3      #include <ctype.h> /* defs for char conversion */
 4
 5      #define EOT 0x1A /* Control+Z signals EOT */
 6
 7      void main (void) {
 8 1      unsigned char c;
 9 1
10 1      /* setup serial port hwd (2400 Baud @12 MHz) */
11 1      SCON = 0x52; /* SCON */
12 1      TMOD = 0x20; /* TMOD */
13 1      TCON = 0x69; /* TCON */
14 1      TH1 = 0xF3; /* TH1 */
15 1
16 1      while ((c = getchar ()) != EOF) {
17 2          putchar (toupper (c));
18 2      }
19 1      P0 = 0; /* clear Output Port to signal ready */
20 1      }

```

ASSEMBLY LISTING OF GENERATED OBJECT CODE

```

; FUNCTION main (BEGIN)
; SOURCE LINE # 7
0000 759852      MOV      SCON,#052H      ; SOURCE LINE # 11
; SOURCE LINE # 12
0003 758920      MOV      TMOD,#020H
; SOURCE LINE # 13
0006 758869      MOV      TCON,#069H
; SOURCE LINE # 14
0009 758DF3      MOV      TH1,#0F3H
000C      ?C0001:
; SOURCE LINE # 16
000C 120000      E        LCALL   _getchar
000F 8F00      R        MOV     c,R7
0011 EF        MOV     A,R7
0012 F4        CPL     A
0013 6008      JZ      ?C0002
; SOURCE LINE # 17
0015 120000      E        LCALL   _toupper
0018 120000      E        LCALL   _putchar
; SOURCE LINE # 18
001B 80EF      SJMP   ?C0001
001D      ?C0002:
; SOURCE LINE # 19
001D E4        CLR     A
001E F580      MOV     P0,A
; SOURCE LINE # 20
0020 22        RET
; FUNCTION main (END)

```

```

MODULE INFORMATION:  STATIC OVERLAYABLE
CODE SIZE           = 33  ----
CONSTANT SIZE       = ----  ----
XDATA SIZE          = ----  ----
PDATA SIZE          = ----  ----
DATA SIZE           = ----  1
IDATA SIZE          = ----  ----
BIT SIZE            = ----  ----
END OF MODULE INFORMATION.

```

C51 COMPILATION COMPLETE. 0 WARNING(S), 0 ERROR(S)

The C51 Compiler produces a listing file with line numbers and the time and date of compilation.

Information about compiler invocation and the object file generated is printed.

The listing contains a line number before each source line and the instruction nesting { } level.

If errors or possible sources of errors exist an error or warning message is displayed.

Enable under *µVision2 Options for Target - Listing - Assembly Code* the C51 **CODE** directive. This gives you an assembly listing file with embedded source line numbers.

A memory overview provides information about the occupied 8051 memory areas.

The number of errors and warnings in the program are included at the end of the listing.

A51 Macro Assembler

The A51 Assembler is a macro assembler for the 8051 microcontroller family. It translates symbolic assembler language mnemonics into executable machine code. The A51 Assembler allows you to define each instruction in an 8051 program and is used where utmost speed, small code size, and exact hardware control is essential. The assembler's macro facility saves development and maintenance time since common sequences need only be developed once.

Source-Level Debugging

The A51 Assembler generates complete line number, symbol, and type information in the object file created. This allows exact display of program variables in your debugger. Line numbers are used for source-level debugging of your assembler programs with the μ Vision2 Debugger or third-party emulator.

3

Functional Overview

The A51 Assembler translates an assembler source file into a relocatable object module. It generates a listing file optionally with symbol table and cross reference. The A51 Assembler supports two different macro processors:

- The **Standard Macro Processor** is the easier macro processor to use. It allows you to define and use macros in your 8051 assembly programs. The standard macro syntax is compatible with that used in many other assemblers.
- The **Macro Processing Language (MPL)** is a string replacement facility that is fully compatible with the Intel ASM51 macro processor. MPL has several predefined macro processor functions that perform many useful operations like string manipulation or number processing.

Another powerful feature of the A51 Assembler macro processors is conditional assembly depending on command line directives or assembler symbols. Conditional assembly of sections of code can help you achieve the most compact code possible. It also allows you to generate different applications from one assembly source file.

Listing File

Following is an example listing file generated by the assembler.

```

A51 MACRO ASSEMBLER Test Program 07/01/99 08:00:00 PAGE 1
DOS MACRO ASSEMBLER A51 V6.00
OBJECT MODULE PLACED IN SAMPLE.OBJ
ASSEMBLER INVOKED BY: C:\KEIL\C51\BIN\A51.EXE SAMPLE.A51 XREF

LOC OBJ LINE SOURCE
1 $TITLE ('Test Program')
2 NAME SAMPLE
3
4 EXTRN CODE (PUT_CRLF, PUTSTRING, InitSerial)
5 PUBLIC TXTBIT
6
7 PROG SEGMENT CODE
8 CONST SEGMENT CODE
9 BITVAR SEGMENT BIT
10
---- 11 CSEG AT 0
12
0000 020000 F 13 Reset: JMP Start
14
---- 15 RSEG PROG
16 ; *****
0000 120000 F 17 Start: CALL InitSerial ;Init Serial Interface
18
19 ; This is the main program. It is an endless
20 ; loop which displays a text on the console.
0003 C200 F 21 CLR TXTBIT ; read from CODE
0005 900000 F 22 Repeat: MOV DPTR,#TXT
0008 120000 F 23 CALL PUTSTRING
000B 120000 F 24 CALL PUT_CRLF
000E 80F5 25 SJMP Repeat
26 ;
---- 27 RSEG CONST
0000 54455354 28 TXT: DB 'TEST PROGRAM',00H
0004 2050524F
0008 4752414D
000C 00
29
30
31
---- 32 RSEG BITVAR ; TXTBIT=0 read from CODE
0000 33 TXTBIT: DBIT 1 ; TXTBIT=1 read from XDATA
34
35 END

XREF SYMBOL TABLE LISTING
-----
N A M E T Y P E V A L U E ATTRIBUTES / REFERENCES
BITVAR . . . . . B SEG 0001H REL=UNIT 9# 32
CONST . . . . . C SEG 000DH REL=UNIT 8# 27
INITSERIAL . . . . C ADDR ---- EXT 4# 17
PROG . . . . . C SEG 0010H REL=UNIT 7# 15
PUTSTRING . . . . C ADDR ---- EXT 4# 23
PUT_CRLF . . . . . C ADDR ---- EXT 4# 24
REPEAT . . . . . C ADDR 0005H R SEG=PROG 22# 25
RESET . . . . . C ADDR 0000H A 13#
SAMPLE . . . . . N NUMB ---- 2
START . . . . . C ADDR 0000H R SEG=PROG 13 17#
TXT . . . . . C ADDR 0000H R SEG=CONST 22 28#
TXTBIT . . . . . B ADDR 0000H.0 R SEG=BITVAR 5 5 21 33#

REGISTER BANK(S) USED: 0

ASSEMBLY COMPLETE. 0 WARNING(S), 0 ERROR(S)

```

A51 produces a listing file with line numbers as well as the time and date of the translation. Information about assembler invocation and the object file generated is printed.

Typical programs start with EXTERN, PUBLIC, and SEGMENT directives.

The listing contains a source line number and the object code generated by each source line.

Error messages and warning messages are included in the listing file. The position of each error is clearly marked.

Enable under *µVision2 Options for Target – Listing – Cross Reference* to get a detailed listing of all symbols used in the assembler source file.

The register banks used, and the total number of warnings and errors are at the end of the listing file.

BL51 Code Banking Linker/Locator

The BL51 code banking linker/locator combines one or more object modules into a single executable 8051 program. The linker resolves external and public references and assigns absolute addresses to relocatable programs segments.

The BL51 code banking linker/locator processes object modules created by the Keil C51 Compiler and A51 Assembler and the Intel PL/M-51 Compiler and ASM-51 Assembler. The linker automatically selects the appropriate run-time library and links only those library modules that are required.

You may invoke the BL51 code banking linker/locator from the command line specifying the names of the object modules to combine. The default controls for the BL51 code banking linker/locator have been carefully chosen to accommodate most applications without the need to specify additional directives. However, it is easy for you to specify custom settings for your application.

3

Data Address Management

The BL51 code banking linker/locator manages the limited internal memory of the 8051 by overlaying variables for functions that are mutually exclusive. This greatly reduces the overall memory requirement of most 8051 applications.

The BL51 code banking linker/locator analyzes the references between functions to carry out memory overlaying. You may use the **OVERLAY** directive to manually control functions references the linker uses to determine exclusive memory areas. The **NOOVERLAY** directive lets you completely disable memory overlaying. These directives are useful when using indirectly called functions or when disabling overlaying for debugging.

Code Banking

The BL51 code banking linker/locator supports the ability to create application programs that are larger than 64 Kbytes. Since the 8051 does not directly support more than 64 Kbytes of code address space, there must be external hardware that swaps code banks. The hardware that does this must be controlled by software running on the 8051. This process is known as bank switching.

The BL51 code banking linker/locator lets you manage 1 common area and 32 banks of up to 64 Kbytes each for a total of 2 Mbytes of bank-switched 8051 program space. Software support for the external bank switching hardware includes a short assembly file you can edit for your specific hardware platform.

The BL51 code banking linker/locator lets you specify the bank in which to locate a particular program module. By carefully grouping functions in the different banks, you can create very large, efficient applications.

Common Area

3

The common area in a bank switching program is an area of memory that can be accessed at all times from all banks. The common area cannot be physically swapped out or moved around. The code in the common area is either duplicated in each bank (if the entire program area is swapped) or can be located in a separate area or EPROM (if the common area is not swapped).

The common area contains program sections and constants that must be available at all times. It may also contain frequently used code. By default, the following code sections are automatically located in the common area:

- Reset and Interrupt Vectors,
- Code Constants,
- C51 Interrupt Functions,
- Bank Switch Jump Table,
- Some C51 Run-Time Library Functions.

Executing Functions in Other Banks

Code banks are selected by additional software-controlled address lines that are simulated using 8051 port I/O lines or a memory-mapped latch.

The BL51 code banking linker/locator generates a jump table for functions in other code banks. When your C program calls a function located in a different bank, it switches the bank, jumps to the desired function, restores the previous bank (when the function completes), and returns execution to the calling routine.

The bank switching process requires approximately 50 CPU cycles and consumes an additional 2 bytes of stack space. You can dramatically improve system performance by grouping interdependent functions in the same bank. Functions that are frequently invoked from multiple banks should be located in the common area.

Map File

Following is an example listing file generated by BL51.

```

BL51 BANKED LINKER/LOCATER V4.00      07/01/99  08:00:00  PAGE 1

MS-DOS BL51 BANKED LINKER/LOCATER V4.00, INVOKED BY:
C:\KEIL\C51\BIN\BL51.EXE SAMPLE.OBJ

MEMORY MODEL: SMALL

INPUT MODULES INCLUDED:
SAMPLE.OBJ (SAMPLE)
C:\C51\LIB\C51S.LIB (?C_STARTUP)
C:\C51\LIB\C51S.LIB (PUTCHAR)
C:\C51\LIB\C51S.LIB (GETCHAR)
C:\C51\LIB\C51S.LIB (TOUPPER)
C:\C51\LIB\C51S.LIB (_GETKEY)

LINK MAP OF MODULE:  SAMPLE (SAMPLE)

      TYPE      BASE      LENGTH      RELOCATION      SEGMENT NAME
-----
* * * * *      D A T A      M E M O R Y      * * * * *
REG      0000H      0008H      ABSOLUTE      "REG BANK 0"
DATA     0008H      0001H      UNIT          ?DT?GETCHAR
DATA     0009H      0001H      UNIT          DATA_GROUP
          000AH      0016H
BIT      0020H.0    0000H.1    UNIT          ?BI?GETCHAR
          0020H.1    0000H.7    *** GAP ***
IDATA    0021H      0001H      UNIT          ?STACK

* * * * *      C O D E      M E M O R Y      * * * * *
CODE     0000H      0003H      ABSOLUTE
CODE     0003H      0021H      UNIT          ?PR?MAIN?SAMPLE
CODE     0024H      000CH      UNIT          ?C_C51STARTUP
CODE     0030H      0027H      UNIT          ?PR?PUTCHAR?PUTCHAR
CODE     0057H      0011H      UNIT          ?PR?GETCHAR?GETCHAR
CODE     0068H      0018H      UNIT          ?PR?_TOUPPER?TOUPPER
CODE     0080H      000AH      UNIT          ?PR?_GETKEY?_GETKEY

OVERLAY MAP OF MODULE:  SAMPLE (SAMPLE)

SEGMENT      DATA_GROUP
+--> CALLED SEGMENT      START      LENGTH
-----
?C_C51STARTUP
+--> ?PR?MAIN?SAMPLE

?PR?MAIN?SAMPLE      0009H      0001H
+--> ?PR?GETCHAR?GETCHAR
+--> ?PR?_TOUPPER?TOUPPER
+--> ?PR?PUTCHAR?PUTCHAR

?PR?GETCHAR?GETCHAR      -----
+--> ?PR?_GETKEY?_GETKEY
+--> ?PR?PUTCHAR?PUTCHAR

LINK/LOCATE RUN COMPLETE.  0 WARNING(S),  0 ERROR(S)

```

BL51 produces a MAP file (extension .M51) with date and time of the link/locate run.

BL51 displays the invocation line and the memory model.

Each input module and the library modules included in the application are listed.

The memory map contains the usage of the physical 8051 memory.

3

The overlay-map displays the structure of the program and the location of the bit and data segments of each function.

Warning messages and error messages are listed at the end of the MAP file. These may point to possible problems encountered during the link/locate run.

LIB51 Library Manager

The LIB51 library manager lets you create and maintain library files. A library file is a formatted collection of object modules (created by the C compiler and assembler). Library files provide a convenient method of combining and referencing a large number of object modules that may be accessed by the linker/locator.

To build a library with the μ Vision2 project manager enable **Options for Target – Output – Create Library**. You may also call **LIB51** from a DOS box. Refer to “LIB51 / L251 Library Manager Commands” on page 218 for command list.

3

There are a number of benefits to using a library. Security, speed, and minimized disk space are only a few of the reasons to use a library. Additionally, libraries provide a good vehicle for distributing a large number of useful functions and routines without the need to distribute source code. For example, the ANSI C library is provided as a set of library files.

The μ Vision2 project `C:\KEIL\C51\RTX_TINY\RTX_TINY.UV2` allows you to modify and create the RTX51 Tiny real-time operating system library. It is easy to build your own library of useful routines like serial I/O, CAN, and FLASH memory utilities that you may use over and over again. Once these routines are written and debugged, you may merge them into a library. Since the library contains only the object modules, the build time is shortened since these modules do not require re-compilation for each project.

Libraries are used by the linker when linking and locating the final application. Modules in the library are extracted and added to the program only if they are required. Library routines that are not specifically invoked by your program are not included in the final output. The linker extracts the modules from the library and processes them exactly as it does other object modules.

OC51 Banked Object File Converter

The OC51 banked object file converter creates absolute object modules for each code bank in a banked object module. Banked object modules are created by the BL51 code banking linker/locator when you create a bank switching application. Symbolic debugging information is copied to the absolute object files and can be used by the μ Vision2 Debugger or an in-circuit emulator.

You may use the OC51 banked object file converter to create absolute object modules for the command area and for each code bank in your banked object module. You may then generate Intel HEX files for each of the absolute object modules using the OH51 object-hex converter.

OH51 Object-Hex Converter

The OH51 object-hex converter creates Intel HEX files from absolute object modules. Absolute object modules can be created by the BL51 code banking linker or by the OC51 banked object file converter. Intel HEX files are ASCII files that contain a hexadecimal representation of your application. They can be easily loaded into a device programmer for writing EPROMS.

3

Chapter 4. Creating Applications

To make it easy for you to evaluate and become familiar with our product line, we provide an evaluation version with sample programs and limited versions of our tools. The sample programs are also included with our standard product kits.

NOTE

The Keil C51 evaluation tools are limited in functionality and the code size of the application you can create. Refer to the “Release Notes” for more information on the limitations of the evaluation tools. For larger applications, you need to purchase one of our development kits. Refer to “Product Overview” on page 16 for a description of the kits that are available.

This chapter describes the **Build Mode** of μ Vision2 and shows you how to use the user interface to create a sample program. Also discussed are options for generating and maintaining projects. This includes output file options, the configuration of the C51 Compiler for optimum code quality, and the features of the μ Vision2 project manager.

4

Creating Projects

μ Vision2 includes a project manager that makes it easy to design applications for the 8051 family. You need to perform the following steps to create a new project:

- Start μ Vision2, create a project file and select a CPU from the device database.
- Create a new source file and add this source file to the project.
- Add and configure the startup code for the 8051 device
- Set tool options for target hardware.
- Build project and create a HEX file for PROM programming.

The description is a step-by-step tutorial that shows you how to create a simple μ Vision2 project.



Starting μ Vision2 and Creating a Project

μ Vision2 is a standard Windows application and started by clicking on the program icon. To create a new project file select from the μ Vision2 menu **Project – New Project...** This opens a standard Windows dialog that asks you for the new project file name.

We suggest that you use a separate folder for each project. You can simply use the icon **Create New Folder** in this dialog to get a new empty folder. Then select this folder and enter the file name for the new project, i.e. **Project1**. μ Vision2 creates a new project file with the name **PROJECT1.UV2** which contains a default target and file group name. You can see these names in the **Project Window – Files**.

Now use from the menu **Project – Select Device for Target** and select a CPU for your project. The **Select Device** dialog box shows the μ Vision2 device database. Just select the microcontroller you use. We are using for our examples the Philips 80C51RD+ CPU. This selection sets necessary tool options for the 80C51RD+ device and simplifies in this way the tool configuration.

4

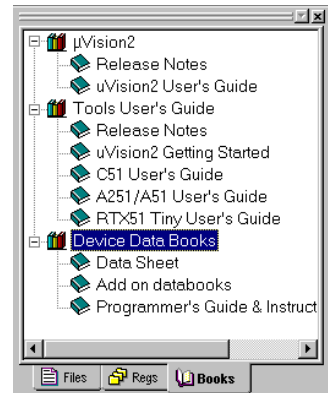
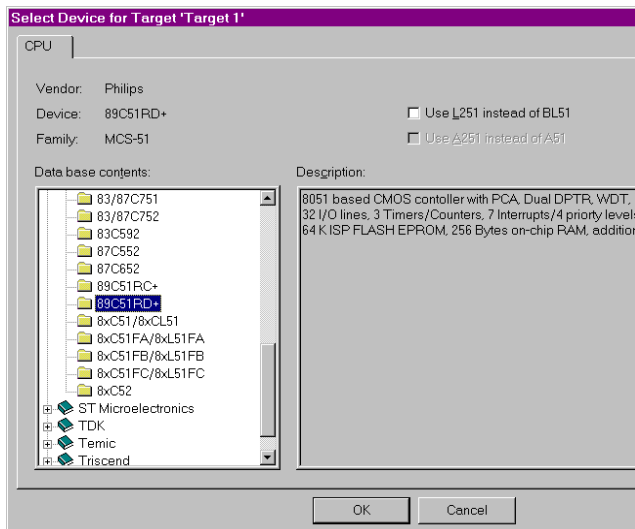

NOTE

On some devices, the μ Vision2 environment needs additional parameters that you have to enter manually. Carefully read the information provided under

Description in this dialog, since it might have additional instructions for the device configuration.

Once you have selected a CPU from the device database you can open the user manuals for that device in the **Project Window – Books** page. These user manuals are part of the Keil Development Tools CD-ROM that should be present in your CD drive.

Creating New Source Files

You may create a new source file with the menu option **File – New**. This opens an empty editor window where you can enter your source code. μ Vision2 enables the C color syntax highlighting when you save your file with the dialog **File – Save As...** under a filename with the extension *.C. We are saving our example file under the name MAIN.C.

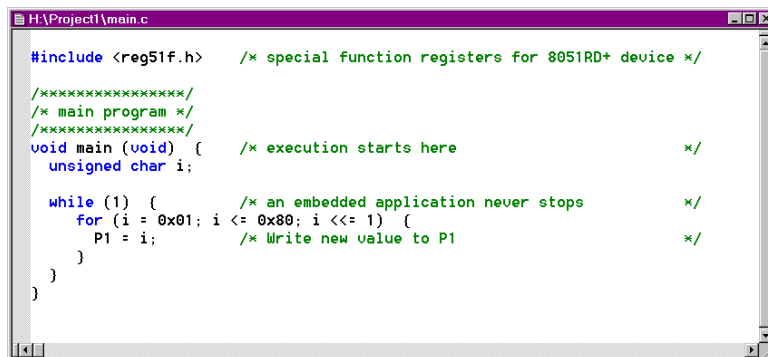

```
H:\Project1\main.c
#include <reg51f.h> /* special function registers for 8051RD+ device */
/******
/* main program */
/******
void main (Void) { /* execution starts here */
    unsigned char i;

    while (1) { /* an embedded application never stops */
        for (i = 0x01; i <= 0x80; i <<= 1) {
            P1 = i; /* Write new value to P1 */
        }
    }
}
```

Once you have created your source file you can add this file to your project. μ Vision2 offers several ways to add source files to a project. For example, you can select the file group in the **Project Window – Files** page and click with the right mouse key to open a local menu. The option **Add Files** opens the standard files dialog. Select the file MAIN.C you have just created.

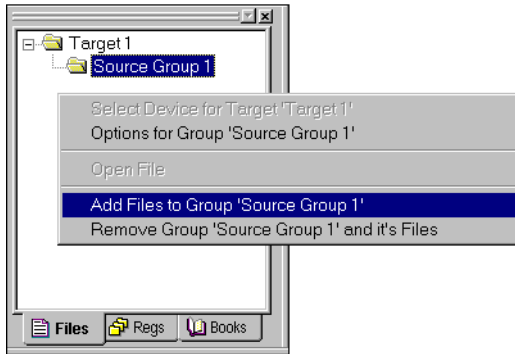

Adding and Configuring the Startup Code

4

The `STARTUP.A51` file is the startup code for the most 8051 CPU variants. The startup code clears the data memory and initializes hardware and reentrant stack pointers. In addition, some 8051 derivatives require a CPU initialization code that needs to match the configuration of your hardware design. For example, the Philips 8051RD+ offers you on-chip xdata RAM that should be enabled in the startup code. Since you need to modify that file to match your target hardware, you should copy the `STARTUP.A51` file from the folder `C:\KEIL\C51\LIB` to your project folder.

It is a good practice to create a new file group for the CPU configuration files. With **Project – Targets, Groups, Files...** you can open a dialog box where you add a group named **System Files** to your target. In the same dialog box you can use the **Add Files to Group...** button to add the `STARTUP.A51` file to your project.

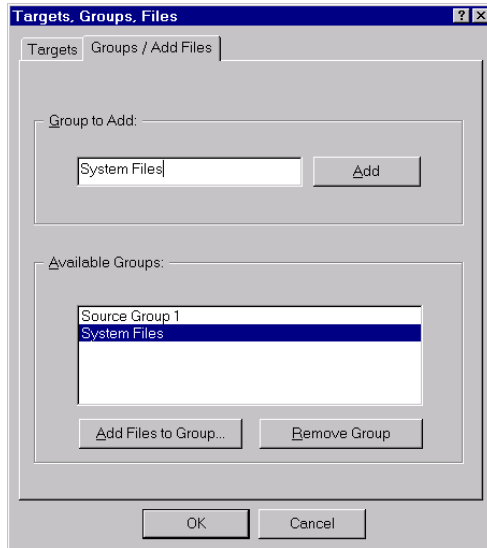

The **Project Window – Files** lists all items of your project.

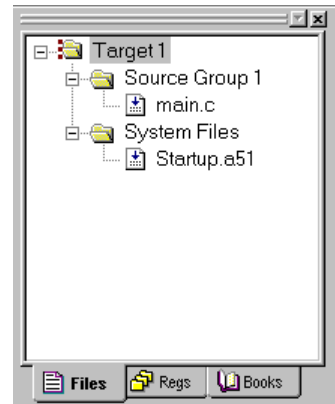

The μ Vision2 **Project Window – Files** should now show the above file structure. Open **STARTUP.A51** in the editor with a double click on the file name in the project window. Then you configure the startup code as described in “Chapter 10. CPU and C Startup Code” on page 197. If you are using on-chip RAM of your device the settings in the startup code should match the settings of the **Options – Target** dialog. This dialog is discussed in the following.



Setting Tool Options for Target

µVision2 lets you set options for your target hardware. The dialog **Options for Target** opens via the toolbar icon. In the **Target** tab you specify all relevant parameters of your target hardware and the on-chip components of the device you have selected. The following the settings for our example are shown.

4

The following table describes the options of the **Target** dialog:

Dialog Item	Description
Xtal	Specifies the CPU clock of your device. In most cases this value is identical with the XTAL frequency.
Memory Model	Specifies the C51 Compiler memory model. For starting new applications the default SMALL is a good choice. Refer to “Memory Models and Memory Types” on page 78 for a discussion of the various memory models.
Allocate On-chip ... Use multiple DPTR registers	Specifies the usage of the on-chip components that are typically enabled in the CPU startup code. If you are using on-chip xdata RAM (XRAM) you should also enable the XRAM access in the STARTUP.A51 file.
Off-chip ... Memory	Here you specify all external memory areas of the target hardware.
Code Banking Xdata Banking	Specifies the parameters for code and xdata banking. Refer to “Code Banking” on page 67 for more information.

NOTE

Several Options in the Target dialog are only available if you are using the LX51 Linker/Locator. The LX51 Linker/Locator is only available in the PK51 package.

Building Projects and Creating a HEX Files

Typical, the tool settings under **Options – Target** are all you need to start a new application. You may translate all source files and line the application with a click on the **Build Target** toolbar icon. When you build an application with syntax errors, μ Vision2 will display errors and warning messages in the **Output Window – Build** page. A double click on a message line opens the source file on the correct location in a μ Vision2 editor window.

```
Build target 'Target 1'
compiling main.c...
.MAIN.C(14): error 67: 'var': undefined identifier
.MAIN.C(15): error 67: 'Port7': undefined identifier
.MAIN.C(8): warning 47: 'j': unreferenced local variable
.MAIN.C(13): warning 47: 'lab': unreferenced label
Target not created
```

```
Build target 'Target 1'
compiling main.c...
assembling Startup.a51...
linking...
creating hex file from "Project1"...
"Project1" - 0 Error(s), 0 Warning(s).
```

Once you have successfully generated your application you can start debugging. Refer to “Chapter 5. Testing Programs” on page 93 for a discussion of the μ Vision2 debugging features. After you have tested your application, it is required to create an Intel HEX file to download the software into an EPROM programmer or simulator. μ Vision2 creates HEX files with each build process when **Create HEX file** under **Options for Target – Output** is enabled. You may start your PROM programming utility after the make process when you specify the program under the option **Run User Program #1**.

4

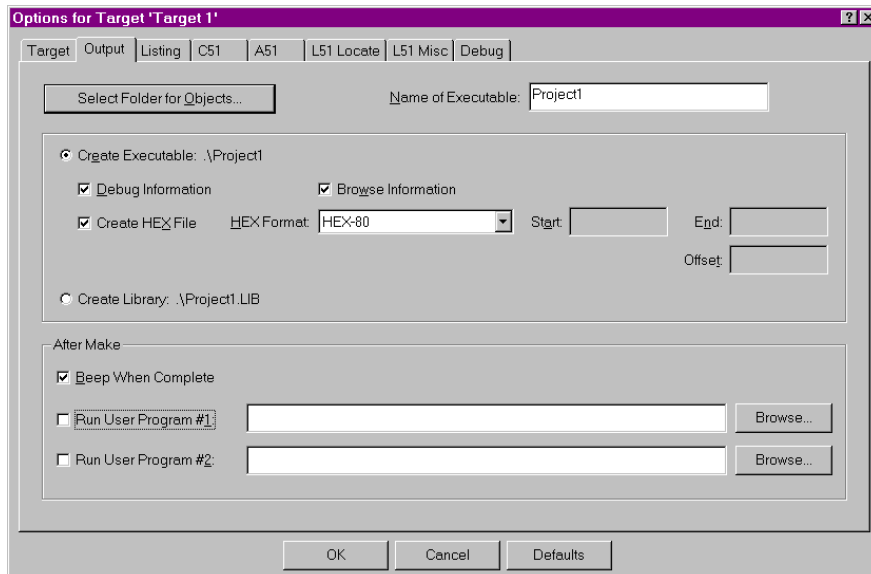

Now you can modify existing source code or add new source files to the project. The **Build Target** toolbar button translates only modified or new source files and generates the executable file. μ Vision2 maintains a file dependency list and knows all include files used within a source file. Even the tool options are saved in the file dependency list, so that μ Vision2 rebuilds files only when needed. With the **Rebuild Target** command, all source files are translated, regardless of modifications.

Project Targets and File Groups

By using different **Project Targets** μ Vision2 lets you create several programs from a single project. You may need one target for testing and another target for a release version of your application. Each target allows individual tool settings within the same project file.

Files Groups let you group associated files together in a project. This is useful for grouping files into functional blocks or for identifying engineers in your software team. We have already used file groups in our example to separate the CPU related files from other source files. With these techniques it is easily possible to maintain complex projects with several 100 files in μ Vision2.

The **Project – Targets, Groups, Files...** dialog allows you to create project targets and file groups. We have already used this dialog to add the system configuration files. An example project structure is shown below.

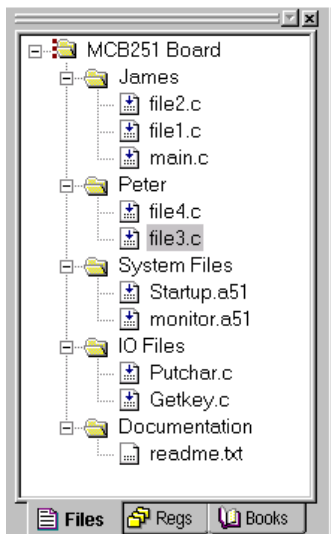

The **Project Windows** shows all groups and the related files. Files are built and linked in the same order as shown in this window. You can move file positions with **Drag & Drop**. You may select a target or group name and **Click** to rename it. The local menu opens with a right mouse **Click** and allows you to:

- Set tool options
- Add files to a group
- Remove the item
- Open the file.

In the build toolbar you can quickly change the current project target to build.

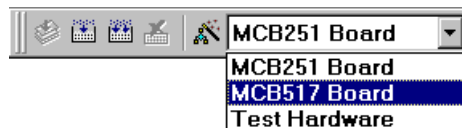

Viewing File and Group Attributes in the Project Window

Different icons are used in the **Project Window – Files** page to show the attributes of files and file groups. These icons are explained below:



Files that are translated and linked into the project are marked with an arrow in the file icon.



Files that are excluded from the link run do not have the arrow. This is typical for document files. However you may exclude also source files when you disable **Include in Target Build** in the **Properties** dialog. See also “File and Group Specific Options – Properties Dialog” on page 87.



Read only files are marked with a key. This is typical for files that are checked into a Software Version Control System, since the SVCS makes the local copy of such files read only. See also “Using the SVCS Menu” on page 76.



Files or file groups with specific options are marked with dots. Refer to “File and Group Specific Options – Properties Dialog” on page 87 for more information.

NOTE

The different icons give you quick overview of the tool settings in the various targets of a project. The icons reflect always the attributes of the current selected target. For example, if you have set specific options on a file or file group in one target, then the dots in the icon are only shown if this target is currently selected.

Overview of Configuration Dialogs

The options dialog lets you set all the tool options. Via the local menu in the **Project Window – Files** you may set different options for a file group or even a single file; in this case you get only the related dialog pages. With the context help button  you get help on most dialog items. The following table describes the options of the **Target** dialog.

Dialog Page	Description
Target	Specify the hardware of your application. See page 62 for details.
Output	Define the output files of the tool chain and allows you to start user programs after the build process. See page 82 for more information.
Listing	Specify all listing files generated by the tool chain.
C51	Set C51 Compiler specific tool options like code optimization or variable allocation. Refer to “Other C51 Compiler Directives” on page 80 for information.
A51, AX51	Set assembler specific tool options like macro processing.
L51 Locate LX51 Locate	Define the location of memory classes and segments. Typical you will enable Use Memory Layout from Target Dialog as show below to get automatic settings. Refer to “Locating Segments to Absolute Memory Locations” on page 86 for more information on this dialog.
L51 Misc LX51 Misc	Other linker related settings like Warning or memory Reserve directive.
Debug	Settings for the μ Vision2 Debugger. Refer to page 101 for more information.
Properties	File information and special options for files and groups refer to “File and Group Specific Options – Properties Dialog” on page 87.

4

Below the **L51 Locate** dialog page is shown. When you enable **Use Memory Layout from Target Dialog** μ Vision2 uses the memory information from the selected Device and the Target page. You may still add additional segments to these settings.

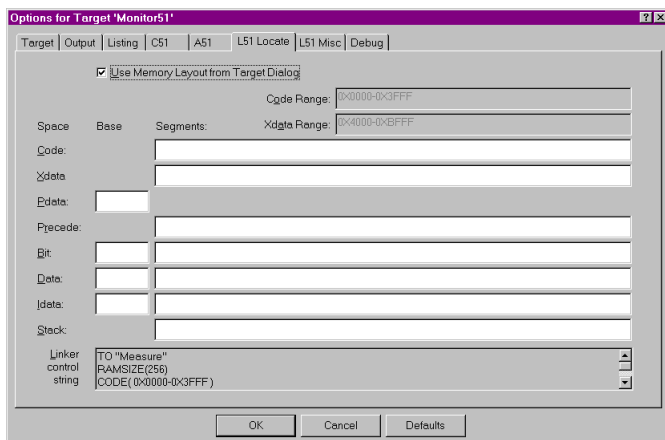

Code Banking

A standard 8051 device has an address range of 64 KBytes for code space. To expand program code beyond this 64KB limit, the Keil 8051 tools support code banking. This technique lets you manage one common area and 32 banks of up to 64 Kbytes each for a total of 2 Mbytes of bank-switched memory.

For example, your hardware design may include one 32K ROM mapped from address 0000h to 7FFFh (known as the common area or common ROM) and four 32K ROMs mapped from code address 8000h to 0FFFFh (known as the code bank ROMs). The code bank ROMs are typically selected via port bits. The figure on the right shows this memory structure.

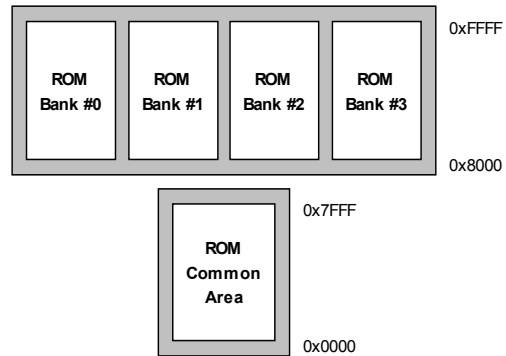

Code banking is enabled and configured in the **Options for Target – Target** dialog. Here you enter the number of code banks supported by your hardware and the banked area. For the above memory example the entries shown on the right are required.

For the configuration of your banking hardware you need to add the file `C51\LIB\L51_BANK.A51` to your project. Copy this file into the project folder together with the other source files of your project and add it to a file group. The `L51_BANK.A51` file must be modified to match the your target hardware.

For each source file or file group of your project the code bank for the program code can be specified for in the **Options – Properties** dialog.

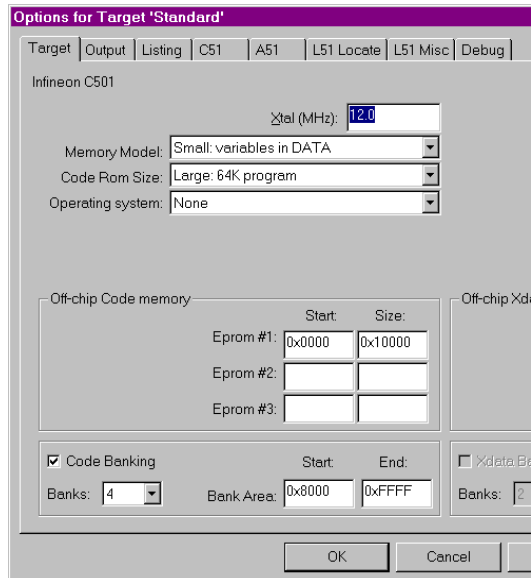

The **Options – Properties** dialog opens with a right mouse click in the project window on the file or file group. This dialog allows you to select the code bank or the common area.

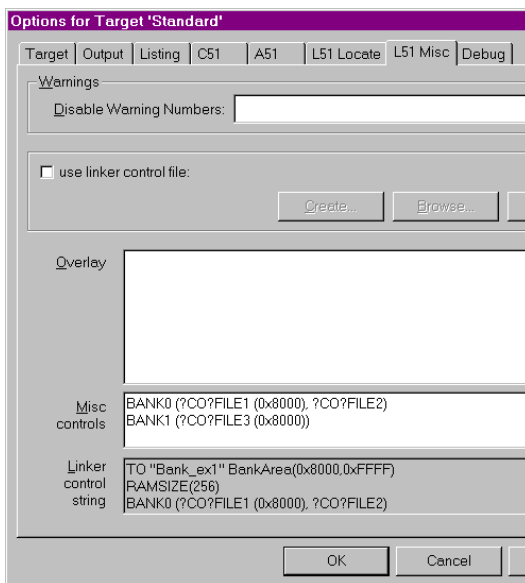
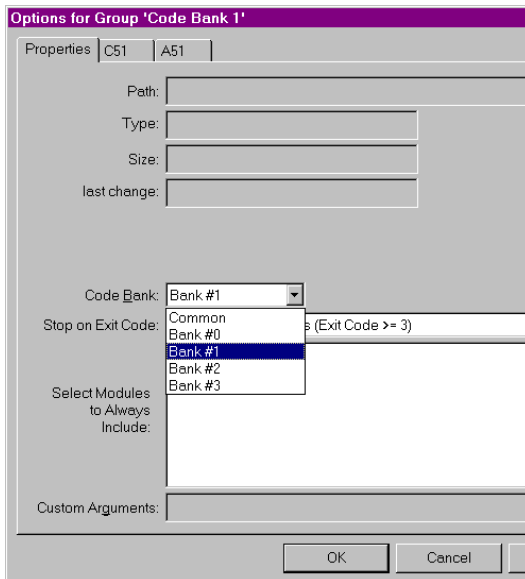
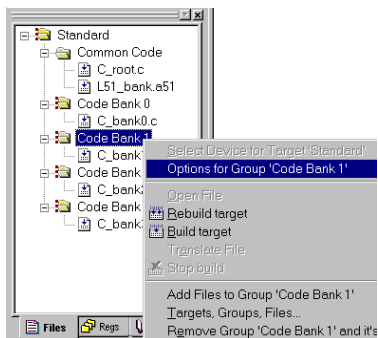

The common code area can be accessed in all code banks. The common area usually includes routines and constant data that must always be accessible, such as: interrupt routines, interrupt and reset vectors, string constants, and bank switch routines. The linker therefore locates only the program segments of a module into the bank area. However, if you can ensure that your program accesses information in constant segments only within a specific code bank, you may locate these segments into this bank using the **BANKx** linker directives in the dialog **Options for Target – L51 Misc**.

The above steps complete the configuration of a your code banking application. The μ Vision2 debugger fully supports code banking and allows you to test your program. If you enable “**Create HEX File**” in the **Options for Target – Output** dialog, the tools generate for each code bank a physical 64KB image that starts at address 0. You need to program these HEX files using your PROM programmer into the correct memory location of your EPROM.

µVision2 Utilities

µVision2 contains many powerful functions that help you during your software project. These utilities are discussed in the following section.

Find in Files

The **Edit – Find in Files** dialog performs a global text search in all specified files. The search results are displayed in the Find in Files page of the Output window. A double click in the Find in Files page positions the editor to the text line with matching string.

Source Browser

The Source Browser displays information about program symbols in your program. If **Options for Target – Output – Browser Information** is enabled when you build the target program, the compiler includes browser information into the object files. Use **View – Source Browser** to open the Browse window.

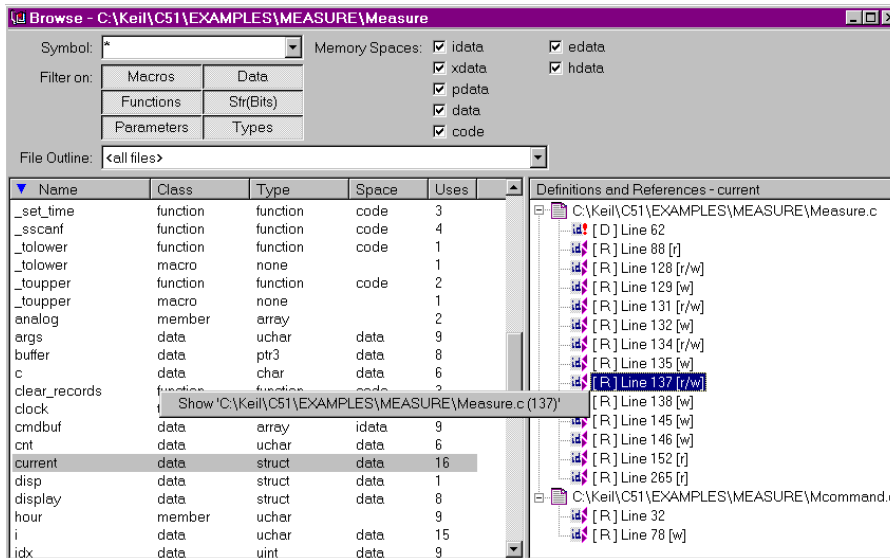

The screenshot shows the Source Browser window for the project 'C:\Keil\C51\EXAMPLES\MEASURE\Measure'. The window is divided into several sections:

- Filter on:** A table with columns for 'Macros', 'Data', 'Functions', and 'Str(Bits)'. The 'Data' and 'Types' options are selected.
- Memory Spaces:** A list of memory spaces with checkboxes: idata, xdata, pdata, data, code, edata, and hdata.
- File Outline:** A dropdown menu showing '<all files>'.
- Table:** A table listing symbols with columns: Name, Class, Type, Space, and Uses. The 'current' symbol is highlighted.
- Definitions and References - current:** A tree view showing the definition of 'current' in 'Measure.c' at line 137, and its references in 'Measure.c' at lines 62, 88, 128, 129, 131, 132, 134, 135, and 138, and in 'Mcommand.c' at line 32.

Name	Class	Type	Space	Uses
_set_time	function	function	code	3
_sscanf	function	function	code	4
_tolower	function	function	code	1
_tolower	macro	none		1
_toupper	function	function	code	2
_toupper	macro	none		1
analog	member	array		2
args	data	uchar	idata	9
buffer	data	ptr3	data	8
c	data	char	data	6
clear_records	function	function	code	2
clock	data	array	idata	9
cmdbuf	data	uchar	data	6
cnt	data	uchar	data	6
current	data	struct	data	16
disp	data	struct	data	1
display	data	struct	data	8
hour	member	uchar		9
i	data	uchar	data	15
idx	data	uint	data	9

The Browse window lists the symbol name, class, type, memory space and the number of uses. Click on the list item to sort the information. You can filter the browse information using the options described in the following table:

Browse Options	Description
Symbol	Specify a mask that is used to match symbol names. The mask may consist of alphanumeric characters plus mask characters: # matches a digit (0 – 9) \$ matches any character * matches zero or more characters.
Filter on	Select the definition type of the symbol
File Outline	Select the file for which information should be listed.
Memory Spaces	Specify the memory type for data and function symbols.

The following table provides a few examples of symbol name masks.

Mask	Matches symbol names ...
*	Matches any symbol. This is the default mask in the Symbol Browser.
##	Matches any symbol that contains one digit in any position.
_a\$##*	Matches any symbol with an underline followed by the letter a followed by any character followed by a digit ending with zero or more characters. For example, _ab1 or _a10value .
_*ABC	Matches any symbol with an underline followed by zero or more characters followed by ABC .

The local menu in the Browse window opens with a right mouse Click and allows you to open the editor on the selected reference. For functions you can also view the Call and Callers graph. The Definitions and References view gives you additional information as shown below:

Symbol	Description
[D]	Definition
[R]	Reference
[r]	read access
[w]	write access
[r/w]	read/write access
[&]	address reference

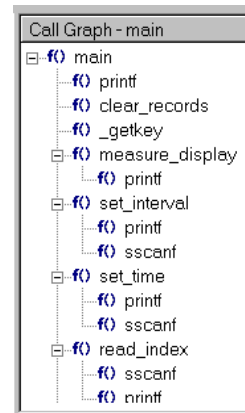

You may use the browser information within an editor window. Select the item that you want to search for and open the local menu with a right mouse click or use the following keyboard shortcuts:

Shortcut	Description
F12	Goto Definition; place cursor to the symbol definition
Shift+F12	Goto Reference; place cursor to a symbol reference
Ctrl+Num+	Goto Next Reference or Definition
Ctrl+Num-	Goto Previous Reference or Definition

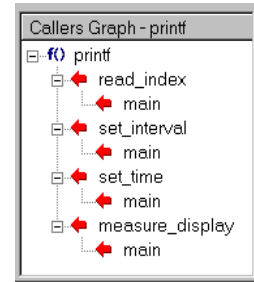

Key Sequence for Tool Parameters

A key sequence may be used to pass arguments from the μ Vision2 environment to external user programs. Key sequences can be applied in the **Tools** menu, **SVCS** menu, and the **Run User Program** arguments in the **Options for Target – Output** dialog. A key sequence is a combination of a **Key Code** and a **File Code**. The available **Key Codes** and **File Codes** are listed in the tables below:

4

Key Code	Specifies the path selected with the File Code
%	Filename with extension, but without path specification (PROJECT1.UV2)
#	Filename with complete path specification (C:\MYPROJECT\PROJECT1.UV2)
%	Filename with extension, but without path specification (PROJECT1.UV2)
@	Filename without extension and path specification (PROJECT1)
\$	Folder name of the file specified in the file code (C:\MYPROJECT)
~ †	Line number of current cursor position (only valid for file code F)
^ †	Column number of current cursor position (only valid for file code F)

† The key code ~ and ^ can be used only in combination with the file code **F**
 To use \$, #, %, @, ~ or ^ in the user program command line, use \$\$, ##, %%, @@, ~~ or ^^.
 For example, @@ gives a single @ in the user program command line.

File Code	Specifies the file name or argument inserted in the user program line
F	Selected file in the Project Window - Files page (MEASURE.C). Returns the project file if the target name is selected or the current active editor file if a group name is selected.
P	Name of the current project file (PROJECT1.UV2)
L	Linker output file, typical the executable file for debugging (PROJECT1)
H	Application HEX file (PROJECT1.H86)
X	μ Vision2 executable program file (C:\KEIL\UV2\UV2.EXE)

The following file codes are used for SVCS systems. For more information refer to "Using the SVCS Menu" on page 76.	
Q †	File name that holds comments for the SVCS system.
R †	String that holds a revision number for the SVCS system.
C †	String that holds a check point string for the SVCS system.
U †	User name specified under SVCS – Configure Version Control – User Name
V †	File name specified under SVCS – Configure Version Control – Database

† The file codes Q, R, C, U and V can be used only in combination with the key code %

Using the Tools Menu

Via the **Tools** menu, you run external programs. You may add custom programs to the **Tools** menu with the dialog **Tools – Customize Tools Menu...**. This dialog configures the parameters for external user applications. The dialog right shows a sample tool setup. The dialog options are explained below.

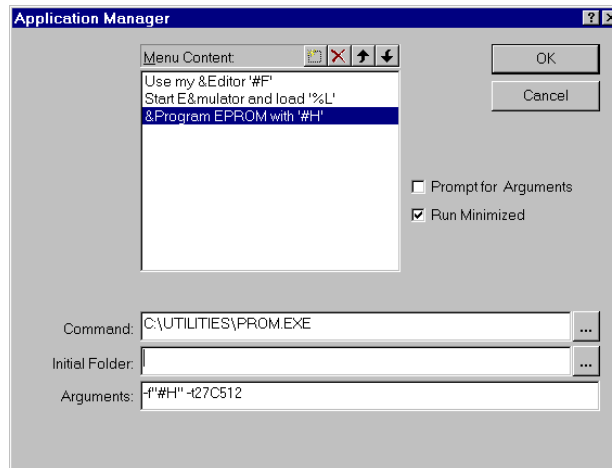

The above entries extend the **Tools** menu as shown right.

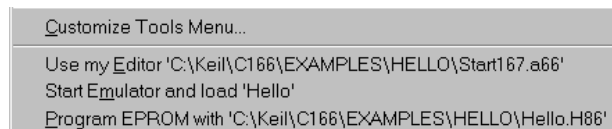

Dialog Item	Description
Menu Content	Text shown in the Tools menu. This line may contain key codes and file codes. Shortcuts are defined with an ampersand ('&') character. The current selected menu line allows you to specify the options listed below.
Prompt for Arguments	If enabled, a dialog box opens at the time you invoke the menu item that allows you to specify the command line arguments for the user program.
Run Minimized	Enable this option to execute the application with minimized window.
Command	Program file that is executed with the selected menu item.
Initial Folder	Current working folder for the application program. If this entry is empty, μ Vision2 uses the base folder of the project file.
Arguments	Command line arguments that are passed to the application program.

The output of command line based application programs is copied to a temporary file. When the application execution completes the content of this temporary file is listed in the **Output Window – Build** page.

Running PC-Lint

PC-Lint from Gimpel Software checks the syntax and semantics of C programs across all modules of your application. PC-Lint flags possible bugs and inconsistencies and locates unclear, erroneous, or non-sense C code. PC-Lint may considerably reduce the debugging effort of your target application.

Install **PC-Lint** on your PC and enter parameters in the dialog **Tools – Setup PC Lint**. The example shows a typical PC-Lint configuration.

To get correct output in the **Build** page, you should use the configuration file that is located in the folder **KEIL/C51/BIN**.

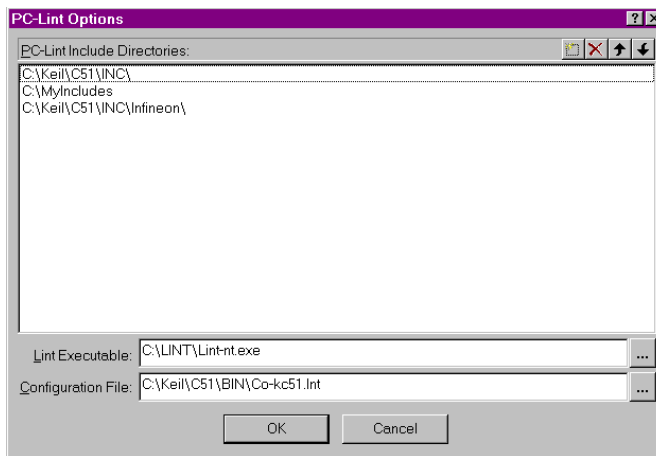

After the setup of PC-Lint you may *Lint* your source code. **Tools – Lint ...** runs PC-Lint on the current in focus editor file. **Tools – Lint All C Source Files** runs PC-Lint across all C source files of your project. The PC-Lint messages are redirected to the **Build – Output Window**. A double click on a Lint message line locates the editor to the source file position.

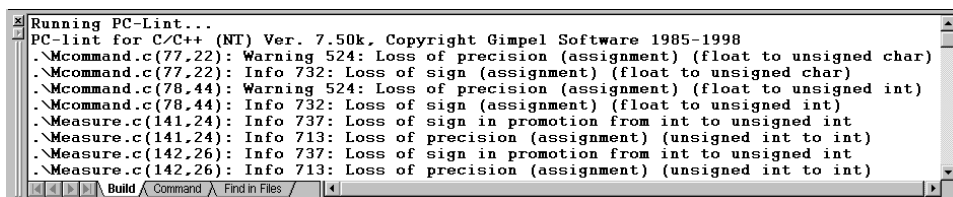

To get correct results in the **Build – Output Window**, PC-Lint needs the following option lines in the configuration file:

```
-hsb_3 // 3 lines output, column below
-format="*** LINT: (%f(%1) %)%t %n: %m" // Change message output format
-width(0,10) // Don't break lines
```

The configuration file `C:\KEIL\C51\BIN\CO-KC51.LNT` contains already these lines. It is strongly recommended to use this configuration file, since it contains also other PC-Lint options required for the Keil C51 Compiler.

Siemens Easy-Case

μ Vision2 provides a direct interface to Siemens Easy-Case. Easy-Case is a graphic editor as well as a program documentation utility. You may use Easy-Case to edit source code. Also some μ Vision2 debugger commands are available within the Easy-Case environment.

Install Easy-Case: to use μ Vision2 debugger commands within Siemens Easy-Case the configuration settings from the file `C:\KEIL\UV2\UV2EASY-CPP.INI` should be added to the file `EASY-CPP.INI` that is stored in the `WINDOWS` system directory. This may be done with any text editor or the DOS copy command:

```
C:\>CD C:\WINNT
C:\WINNT>COPY EASY-CPP.INI+C:\KEIL\UV2\UV2EASY-CPP.INI EASY-CPP.INI
```

In the μ Vision2 dialog **Tools – Setup Easy-Case** enter the path for `EASY-CPP.EXE`. This completes the configuration for Siemens Easy-Case.

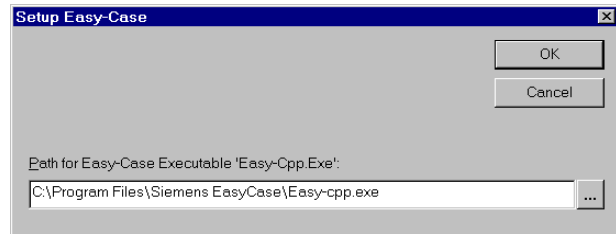

View Source Code with Easy-Case: with **Tools – Start/Stop Easy-Case** you start Easy-Case. The menu item **Tools – Show ...** opens the active μ Vision2 editor file at the current position. The Easy-Case menu **μ Vision2** offers several debug commands that allow program execution in the μ Vision2 debugger.

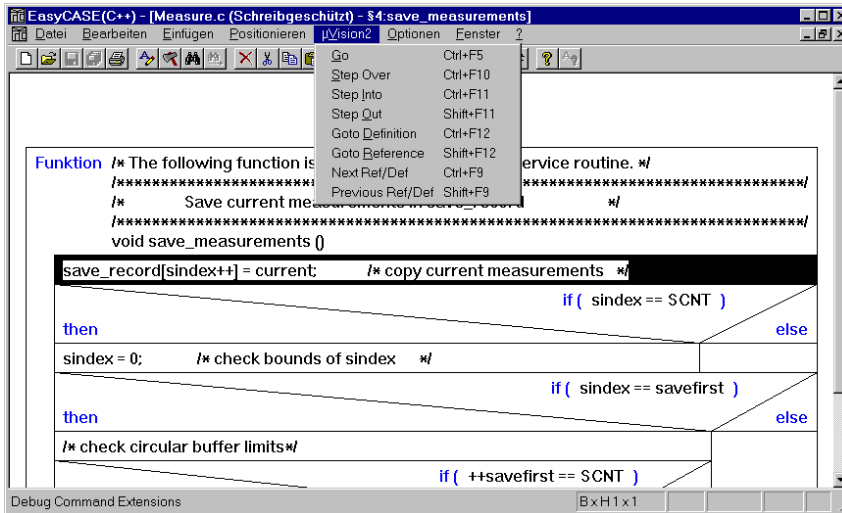

4

Using the SVCS Menu

µVision2 provides a configurable interface to Software Version Control Systems (SVCS). Pre-configured template files are provided for: Intersolv PVCS, Microsoft SourceSafe, and MKS Source Integrity.

Via the SVCS Menu you call the command line tools of your Version Control System. The configuration of the SVCS menu is stored in a **Template File**. This menu is configured with the dialog **SVCS – Customize SVCS Menu...** The dialog options are explained below.

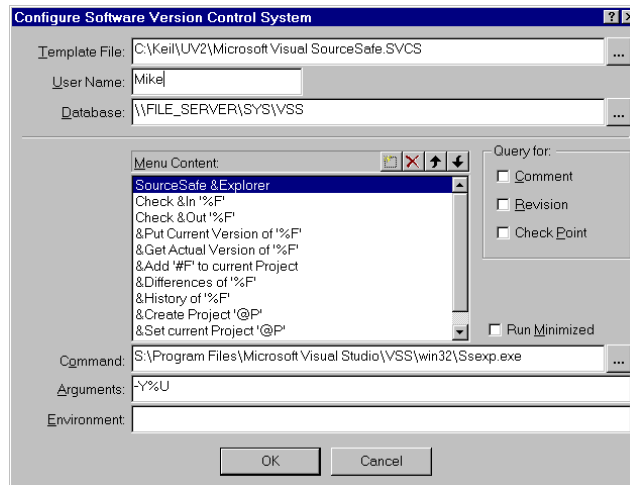

Dialog Item	Description
Template File	Name of the SVCS menu configuration file. It is recommended that all members of the software team are using the same template file. Therefore the template file should be copied to the file server.

User Name	User name that should be used to log into the SVCS system. The user name is passed with the %U file code in the argument line.
Database	File name or path for the database used by the SVCS system. The database string is passed with the %V file code in the argument line.
Menu Content	Text shown in the SVCS menu. This line may contain key codes and file codes. Shortcuts are defined with an ampersand ('&') character. The selected menu line allows you to specify the options listed below.
Query for ... Comment Revision CheckPoint	Allows you to ask for additional information when using the SVCS command. A comment is copied into a temporary file that can be passed with the file code %Q as argument to the SVCS command. Revision and CheckPoint are passed as a string with %R and %C file code.
Run Minimized	Enable this option to execute the application with minimized window.
Command	Program file that is invoked when you click on the SVCS menu item.
Arguments	Command line arguments that are passed to the SVCS program file.
Environment	Environment variables that are set before execution of the SVCS program.

The output of command line SVCS application programs is copied to a temporary file. When the SVCS command completes the content of this temporary file is listed in the **Output Window – Build** page.

A sample SVCS menu is shown on the right. A selected file in the page **Project Window – Files** is the SVCS argument. The target name selects the *.UV2 project file. The local copy of a looked file is read-only and gets a key symbol.

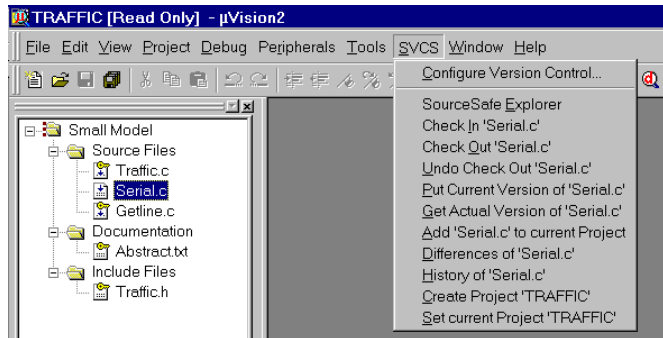

μVision2 projects are saved in two separate files. Project settings in *.UV2: this file should be looked with the SVCS and is sufficient to re-build an application. The local μVision2 configuration in *.OPT contains window positions and debugger settings.

The following table lists typical SVCS menu items. Depending on your configuration, additional or different items might be available. Include files may be added to the project as document file to access them quickly with the SVCS.

SVCS Menu Item	Description
Explorer	Start the interactive SVCS explorer.
Check In	Save the file in the SVCS database and make the local copy read-only.
Check Out	Get the actual file version from the SVCS and allows modifications.

SVCS Menu Item	Description
Undo Check Out	Undo the check out of a file.
Put Current Version	Save a local file in the SVCS database but still allow modifications to it.
Get Actual Version	Get a current read-only copy of a file from the SVCS.
Add <i>file</i> to Project	Add the file to the SVCS project.
Add <i>file</i> to Project	Add the file to the SVCS project.
Differences, History	Show SVCS information about the file.
Create Project	Create a SVCS project with the same name as the local μ Vision2 project.

NOTES

*The pre-configured *.SVCS files may be modified with a text editor to adapt program paths and tool parameters.*

*Microsoft SourceSafe requires the command **Set Current Project** after you have selected a new μ Vision2 project. Remove the **SSUSER** environment variable from the configuration to use the login name of the workstation.*

MKS Source Integrity is pre-configured to create a project database on a server and a local sandbox workspace on the workstation.

Intersolv PVCS is not pre-configured for creating and maintaining projects.

4

Writing Optimum Code

Many configuration parameters have influence on the code quality of your 8051 application. Although, for most applications the default tool setting generates very good code, you should be aware of the parameters that improve code density and execution speed. The code optimization techniques are described in this section.

Memory Models and Memory Types

The most significant impact on code size and execution speed has the memory model. The memory model influences variable accesses. Refer to “Memory Models” on page 35 for detailed information. The memory model is selected in the **Options for Target – Target** dialog page.

Global Register Optimization

The Keil 8051 tools provide support for application wide register optimization that is enabled in the Options for Target – C51 dialog with **Global Register Optimization**. With the application wide register optimization, the C51 Compiler *knows* the registers used by external functions. Registers that are not altered in external functions can be used to hold register variables. The code generated by the C compiler needs less data and code space and executes faster. To improve the register allocation, the μ Vision2 build process makes automatically iterative re-translations of C source files.

In the following example *input* and *output* are external functions, which require only a few registers.

With Global Register Optimization	Without Global Register Optimization
<pre>main () { unsigned char i; unsigned char a; while (1) { i = input (); </pre>	<pre>/* get number of values */ </pre>
<pre>?C0001: LCALL input ;- 'i' assigned to 'R6' - MOV R6,AR7 </pre>	<pre>?C0001: LCALL input MOV DPTR,#i MOV A,R7 MOV @DPTR,A </pre>
<pre> do { a = input (); </pre>	<pre>/* get input value */ </pre>
<pre>?C0005: LCALL input ;- 'a' assigned to 'R7' - MOV R5,AR7 </pre>	<pre>?C0005: LCALL input MOV DPTR,#a MOV A,R7 MOVX @DPTR,A </pre>
<pre> output (a); </pre>	<pre>/* output value */ </pre>
<pre> LCALL _output </pre>	<pre> LCALL _output </pre>
<pre> } while (--i); </pre>	<pre>/* decrement values */ </pre>
<pre> DJNZ R6,?C0005 </pre>	<pre> MOV DPTR,#i MOVX A,@DPTR DEC A MOVX @DPTR,A JNZ ?C0005 </pre>
<pre> } </pre>	
<pre> SJMP ?C0001 </pre>	<pre> SJMP ?C0001 </pre>
<pre> } </pre>	
<pre> RET </pre>	<pre> RET </pre>
Code Size: 18 Bytes	Code Size: 30 Bytes

Other C51 Compiler Directives

There are several other C51 directives that improve the code quality. These directives are enabled in the Options – C51 dialog page. You can translate the C modules in an application with different compiler settings. You may check the code quality of different compiler settings in the listing file.

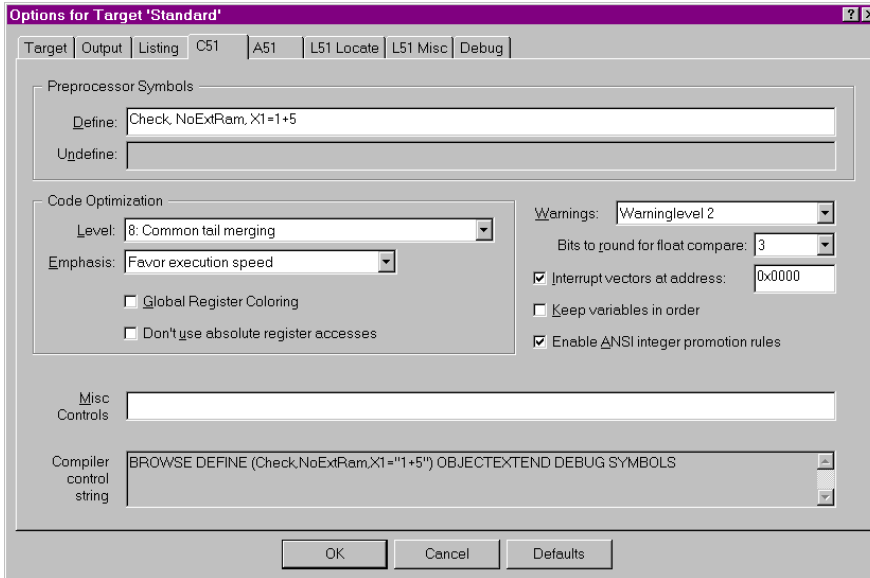

The following table describes the options of the C51 dialog page:

Dialog Item	Description
Define	outputs the C51 DEFINE directive to enter preprocessor symbols.
Undefine	is only available in the Group and File Options dialog and allows you to remove DEFINE symbols that are specified at the higher target or group level.
Code Optimization Level	specifies C51 OPTIMIZE level. Typical you will not alter the default. With the highest level “9: Common block subroutine packing” the compiler detects multiple instruction sequences and packs such code into subroutines. While analyzing the code, the compiler also tries to replace sequences with cheaper instructions. Since the compiler inserts subroutines and CALL instructions, the execution speed of the optimized code might be slower. Typical this level is interesting to optimize the code density.
Code Optimization Emphasis	You can optimize for execution speed or code size. With “Favor Code Size”, the C51 Compiler uses library calls instead of fast replacement code.
Global Register Optimization	enables the “Global Register Optimization”. Refer to page 79 for details.

Dialog Item	Description
Don't use absolute register accesses	disables absolute register addressing for registers R0 through R7. The code will be slightly longer, since C51 cannot use <i>ARx</i> symbols, i.e. in PUSH or POP instructions and needs to insert replace code. However the code will be independent of the selected register bank.
Warnings	selects the C51 warninglevel. Warninglevel 0 disables all warnings.
Bits to round for float compare	determines the number of bits to rounded before a floating-point compare is executed.
Interrupt vectors at address	instructs the C51 Compiler to generate interrupt vectors for interrupt functions and specifies the base address for the interrupt vector table.
Keep Variables in Order	tells the C51 Compiler to order the variables in memory according their definition in the C source file. This option does not influence code quality.
Enable ANSI interger promotion rules	expressions used in if statements are promoted from smaller types to integer expressions before comparison. This gives typically longer code, but is required to be ANSI compatible.
Misc Controls	allows you to enter special C51 directives. You may need such options when you are using very new 8051 devices that require special directives.
Compiler Control String	displays the C51 Compiler invocation string. Allows you can verify the compiler options currently for your source files.

Data Types

The 8051 CPU is an 8-bit microcontroller. Operations that use 8-bit types (like **char** and **unsigned char**) are more efficient than operations that use int or long types.

Tips and Tricks

The following section discusses advanced techniques you may use with the μ Vision2 project manager. You will not need the following features very often, but readers of this section get a better feeling for the μ Vision2 capabilities.

Importing Project Files from μ Vision Version 1

You can import project files from μ Vision1 with the following procedure:

1. Create a new μ Vision2 project file and select a CPU from the device database as described on page 58. It is important to create the new μ Vision2 project file in the existing μ Vision1 project folder.
2. Select the old μ Vision1 project file that exists in the project folder in the dialog **Project – Import μ Vision1 Project**. This menu option is only available, if the file list of the new **μ Vision2** project file is empty.
3. This command imports the old μ Vision1 linker settings into the linker dialogs. But, we recommend that you are using the μ Vision2 **Options for Target – Target** dialog to define the memory structure of your target hardware. Once you have done that, you should enable **Use Memory Layout from Target Dialog** in the **Options for Target – L51 Locate** dialog and remove the settings for **User Classes** and **User Sections** in this dialog.
4. Check carefully if all settings are copied correctly to the new μ Vision2 project file.
5. You may now create file groups in the new μ Vision2 project as described under “Project Targets and File Groups” on page 64. Then you can **Drag & Drop** files into the new file groups.

NOTE

It is not possible to make a 100% conversion from μ Vision1 project files since μ Vision2 differs in many aspects from the previous version. After you have imported your μ Vision1 check carefully if the tool settings are converted correctly. Some μ Vision1 project settings, for example user translator and library module lists are not converted to the μ Vision2 project. Also the dScope Debugger settings cannot be copied to the μ Vision2 project file.

Running External Tools after the Build Process

The **Options for Target – Output** dialog allows you to enter up to two users programs that are started after a successful build process. Using a key sequence you may pass arguments from the μ Vision2 project manager to these user programs. Refer to “

You may use the browser information within an editor window. Select the item that you want to search for and open the local menu with a right mouse click or use the following keyboard shortcuts:

Shortcut	Description
F12	Goto Definition; place cursor to the symbol definition
Shift+F12	Goto Reference; place cursor to a symbol reference
Ctrl+Num+	Goto Next Reference or Definition
Ctrl+Num-	Goto Previous Reference or Definition

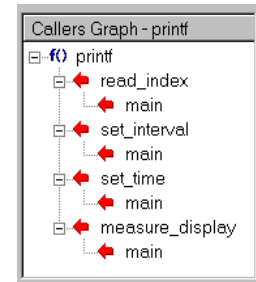

Key Sequence for Tool Parameters” on page 71.

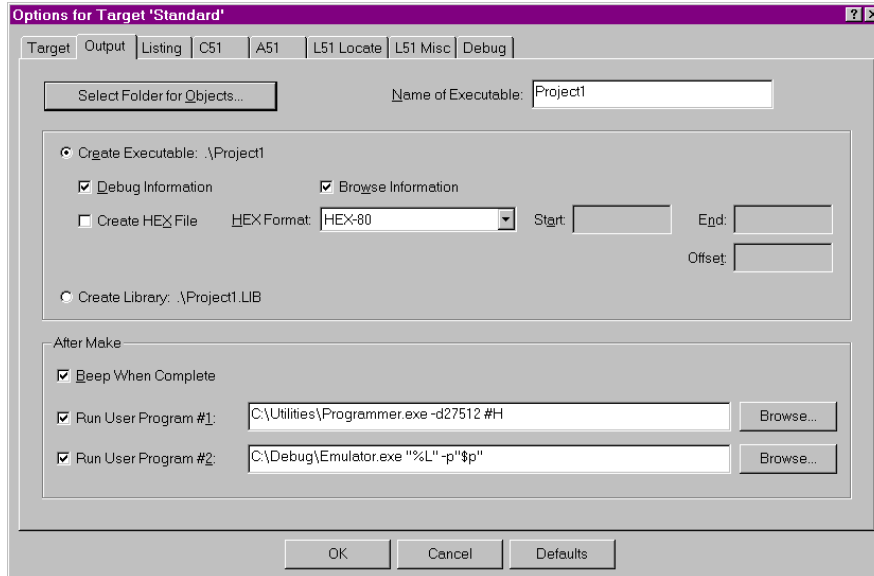

In the example above the **User Program #1** is called with the Hex Output file and the full path specification i.e. `C:\MYPROJECT\PROJECT1.HEX`. The **User program #2** will get only the name of the linker output file `PROJECT1` and as a parameter `-p` the path specification to the project `C:\MYPROJECT`. You should enclose the key sequence with quotes (“”) if you use folder names with special characters, i.e. space, ~, #.

Specifying Separate Folders for Listing Files and Object Files

You can direct the output files of the tools to different folders:

- The **Options for Target – Output** dialog lets you **Select a Folder for Objects**. When you use a separate folder for the object files of each project target, μ Vision2 has still valid object files of the previous build process. Even when you change your project target, a **Build Target** command will just re-translate the modified files.
- The **Options for Target – Listing** dialog provides the same functionality for all listing files with the **Select Folder for List Files** button.

4

Using Microcontrollers That Are Not Listed in the μ Vision2 Device Database

The μ Vision2 device database contains all 8051 standard products. However, there are some custom devices and there will be future devices that are currently not part of this database. If you need to work with an unlisted CPU you have two alternatives:

- Select a device listed under the rubric **Generic**. The **8051 (all Variants)** device allows you to configure all tool parameters and therefore supports all CPU variants. Specify the on-chip memory as External Memory in the **Options for Target – Target** dialog.
- You may enter a new CPU into the μ Vision2 device database. Open the dialog **File – Device Database** and select a CPU that comes close to the device you want to use and modify the parameters. The **CPU** setting in the **Options** box defines the basic the tool settings. The parameters are described in the following table.

Parameter	Specifies ...
IRAM (range)	Address location of the on-chip IRAM.
XRAM (range)	Address location of the on-chip XRAM.
IROM (range)	Address range of the on-chip (flash) ROM. The start address must be 0.
CLOCK (val)	Default CPU clock used when you select the device.
MODA2	Dual DPTR for Atmel device variants.
MODDP2	Dual DPTR for Dallas device variants.
MODDPX	Enables extended 24-bit DPTR register (i.e. for ADuC812).
MODP2	Dual DPTR for Philips and Temic device variants.
MOD517DP	Multiple DPTR for Infineon C500 device variants.
MOD517AU	Arithmetic Unit for Infineon C500 device variants.
MOD_CONT	Enables Dallas 390 Contiguous Mode support.
MX	Enables Philips 80C51MX support.

Other **Option** variables specify CPU data books and μ Vision2 Debugging DLLs. Leave this variables unchanged when adding a new device to the database.

Creating a Library File

Select **Create Library** in the dialog **Options for Target – Output**. μ Vision2 will call the Library Manager instead of the Linker/Locator. Since the code in the Library will be not linked and located, the entries in the **L51 Locate** and **L51 Misc** options page are ignored. Also the CPU and memory settings in the **Target** page are not relevant. Select a CPU listed under the rubric **Generic** in the device database, if you plan to use your code on different 8051 directives.

Copying Tool Settings to a New Target

Select **Copy all Settings from Current Target** when you add a new target in the **Project – Targets, Groups, Files...** dialog. Copy tool settings from an existing target to the current target in following way:

1. Use **Remove Target** to delete the current target.
2. Select the target with the tool settings you want to copy with **Set as Current Target**.
3. **Add** the again removed target with **Copy all Settings from Current Target** enabled.

Locating Segments to Absolute Memory Locations

Sometimes, it is required to locate sections to specific memory addresses. In the following example, the structure called `alarm_control` should be located at address `0xC000`. This structure is defined in a source file named `ALMCTRL.C` and this module contains only the declaration for this structure.

```
:
:
struct alarm_st {
    unsigned int alarm_number;
    unsigned char enable flag;
    unsigned int time_delay;
    unsigned char status;
};

struct alarm_st xdata alarm_control;
:
:
```

4

The C51 Compiler generates an object file for `ALMCTRL.C` and includes a segment for variables in the `xdata` memory area. The variable `alarm_control` is located in the segment `?XD?ALMCTRL`. `µVision2` allows you to specify the base address of any section under **Options for Target – L51 Locate – Users Sections**. In the following example linker/locater will locate the section named `?XD?ALMCTRL` at address `0xC000` in the physical `xdata` memory.

NOTE

C51 offers you `_at_` directive and absolute memory access macros to address absolute memory locations. For more information refer to the “C51 User's Guide”, Chapter 6.

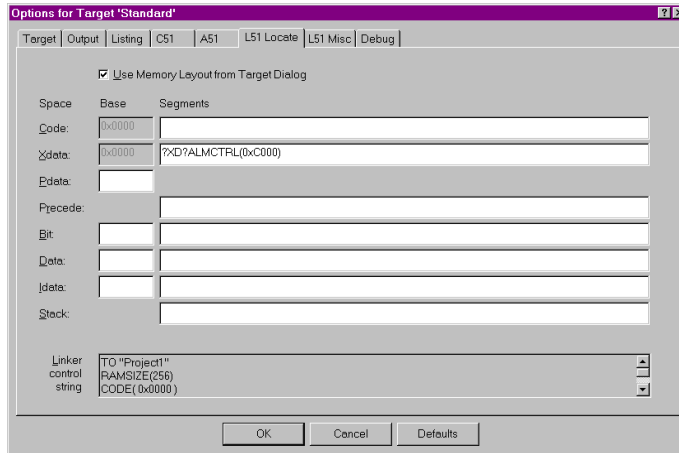

File and Group Specific Options – Properties Dialog

4

µVision2 allows you to set file and group specific options via the local menu in the **Project Window – Files** page as follows: select a file or group, click with the right mouse key and choose **Options for ...**. Then you can review information or set special options for the item selected. The dialog pages have tri-state controls. If a selection is gray or contains *<default>* the setting from the higher group or target level is active. The following table describes the options of the **Properties** dialog page:

Dialog Item	Description
Path, Type, Size Last Change	Outputs information about the file selected.
Include in Target Build	Disable this option to exclude the group or source file in this target. If this option is not set, µVision2 will not translate and not link the selected item into the current targets. This is useful for configuration files, when you are using the project file for several different hardware systems.
Always Build	Enable this option to re-translate a source module with every build process, regardless of modifications in the source file. This is useful when a file contains <code>__DATE__</code> and <code>__TIME__</code> macros that are used to stored version information in the application program.
Generate Assembler SRC File	Instructs the C51 Compiler to generate an assembler source file from this C module. Typical this option is used when the C source file contains #pragma asm / endasm sections.
Assemble SRC File	Use this option together with the Generate Assembler SRC File to translate the assembler source code generated by C51 into an object file that can be linked to the application.

Dialog Item	Description
Link Publics Only	This option is only available with Lx51 and instructs the linker to include only PUBLIC symbols from that module. Typical this option when you want to use entry or variable addresses from a different application. It refers in the most cases to an absolute object file that may be part of the project.
Stop on Exit Code	Specify an exit code when the build process should stop on translator messages. By default, μ Vision2 translates all files in a build process regardless of error or warning messages.
Select Modules to Always Include	Allows you to always include specific modules from a Library. Refer to "Always Including Specific Library Modules" on page 89 for more information.
Custom Arguments	This line is required if your project contains files that need a different translator. Refer to "Using a Custom Translator" on page 90 for more information.

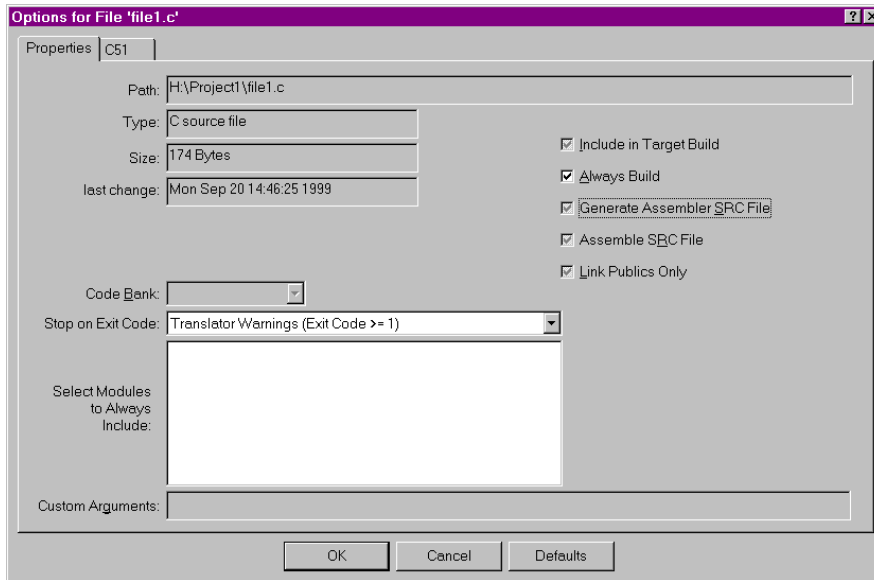

In this example we have specified for **FILE1.C** that the build process is stopped when there are translator warnings and that this file is translated with each build process regardless of modifications.

Translating a C Module with asm / endasm Sections

If you use within your C source module assembler statements, the C51 Compiler requires you to generate an assembler source file and translate this assembler source file. In this case enable the options **Generate Assembler SRC File** and **Assembler SRC File** in the properties dialog.

NOTE

Check if you can use build-in intrinsic functions to replace the assembler code. In general it better to avoid assembler code sections since you C source code will not be portable to other platforms. The C51 Compiler offers you many intrinsic functions that allow you to access all special peripherals. Typically it is not required to insert assembler instructions into C source code.

Always Including Specific Library Modules

The Properties dialog page allows you to specify library modules that should be always included in a project. This is sometimes required when you generate a boot portion of an application that should contain generic routines that are used from program parts that are reloaded later. In this case add the library that contains the desired object modules, open the **Options – Properties** dialog via the local menu in the **Project Window – Files** and **Select Modules to Always Include**.

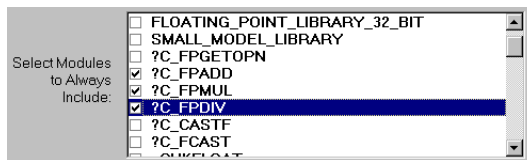

Just enable the modules you want to include in any case into your target application.

Using a Custom Translator

If you add a file with unknown file extension to a project, μ Vision2 requires you to specify the file type for this file. You may select **Custom File** and use a custom translator to process this file. The custom translator is specified along with its command line in the **Custom Arguments** line of the **Options – Properties** dialog. Typical the custom translator will generate a source file from the custom file. You need to add this source file to your project to and use A51 or C51 to generate an object file that can be linked to your application.

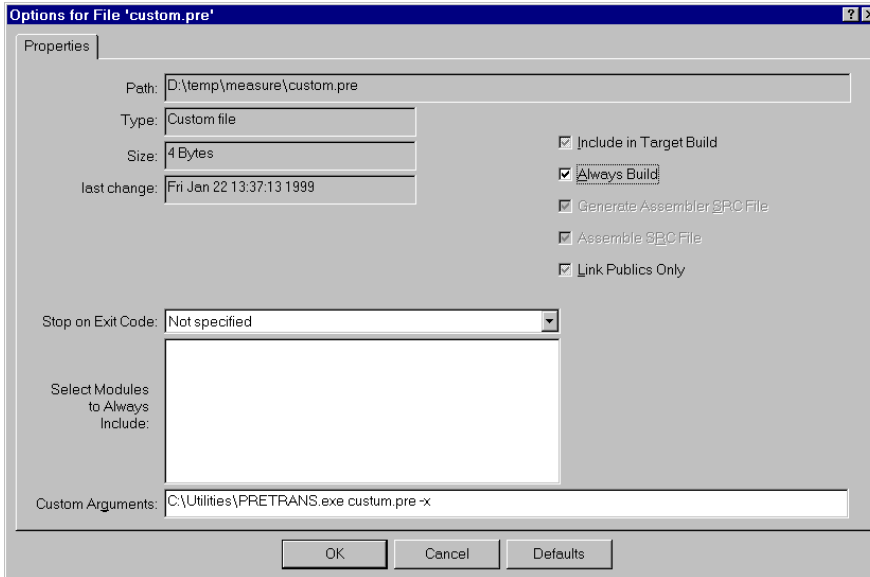

In this example we have specified for **CUSTOM.PRE** that the program **C:\UTILITIES\PRETRANS.EXE** is used with the parameter **-X** to translate the file. Note that we have used also the **Always Build** option to ensure that the file is translated with every build process.

Using Intel PL/M-51

If you still have Intel PL/M-51 source code that you want to include into your μ Vision2 project, you may add these source files as custom translated files in the μ Vision2 project tree. In addition you must insert also the *.OBJ files that are created by PL/M51 and the Intel PLM51.LIB.

The options for the PL/M-51 compiler are set in the **Options – Properties** dialog. This dialog opens with a right mouse click on the source file.

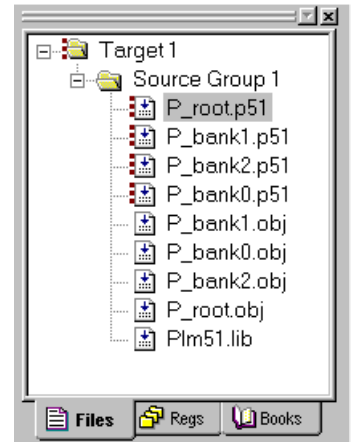

Options for the Intel PL/M-51 Compiler are entered in the Options - Properties dialog under Custom Arguments.

File Extensions

The dialog **Project – File Extensions** allows you to set the default file extension for a project. You can enter several extensions when you separate them with semi-colon characters. The file extensions are project specific.

Different Compiler and Assembler Settings

Via the local menu in the **Project Window – Files** you may set different options for a file group or even a single file. The dialog pages have tri-state controls; if an option is grayed the setting from higher level is taken. You can specify with this technique different tools for a complete file group and still change settings on a single source file within this file group.

4

Version and Serial Number Information

Detailed tool chain information is listed when you open **Help – About**. Please use this information whenever you send us problem reports.

Chapter 5. Testing Programs

μVision2 Debugger

You can use μVision2 Debugger to test the applications you develop using the C51 Compiler and A51 macro assembler. The μVision2 Debugger offers two operating modes that are selected in the **Options for Target – Debug** dialog:

Use Simulator allows you to configure the μVision2 Debugger as *software-only product* that simulates most features of the 8051 microcontroller family without actually having target hardware. You can test and debug your embedded application before the hardware is ready. μVision2 simulates a wide variety of peripherals including the serial port, external I/O, and timers. The peripheral set is selected when you select a CPU from the device database for your target.

Use Advance GDI drivers, like **Keil Monitor 51** interface. With the Advanced GDI interface you may connect the environment directly to emulators or the Keil Monitor program. For more information refer to “Chapter 11. Using Monitor-51” on page 199.

CPU Simulation

μ Vision2 simulates up to 16 Mbytes of memory from which areas can be mapped for read, write, or code execution access. The μ Vision2 simulator traps and reports illegal memory accesses.

In addition to memory mapping, the simulator also provides support for the integrated peripherals of the various 8051 derivatives. The on-chip peripherals of the CPU you have selected are configured from the Device Database selection you have made when you create your project target. Refer to page 58 for more information about selecting a device.

You may select and display the on-chip peripheral components using the **Debug** menu. You can also change the aspects of each peripheral using the controls in the dialog boxes.



Start Debugging

5

You start the debug mode of μ Vision2 with the **Debug – Start/Stop Debug Session** command. Depending on the **Options for Target – Debug** configuration, μ Vision2 will load the application program and run the startup code. For information about the configuration of the μ Vision2 debugger refer to page 101. μ Vision2 saves the editor screen layout and restores the screen layout of the last debug session. If the program execution stops, μ Vision2 opens an editor window with the source text or shows CPU instructions in the disassembly window. The next executable statement is marked with a yellow arrow.

During debugging, most editor features are still available. For example, you can use the find command or correct program errors. Program source text of your application is shown in the same windows. The μ Vision2 debug mode differs from the edit mode in the following aspects:

- The “Debug Menu and Debug Commands” described on page 28 are available. The additional debug windows are discussed in the following.
- The project structure or tool parameters cannot be modified. All build commands are disabled.

Disassembly Window

The Disassembly window shows your target program as mixed source and assembly program or just assembly code. A trace history of previously executed instructions may be displayed with **Debug – View Trace Records**. To enable the trace history, set **Debug – Enable/Disable Trace Recording**.

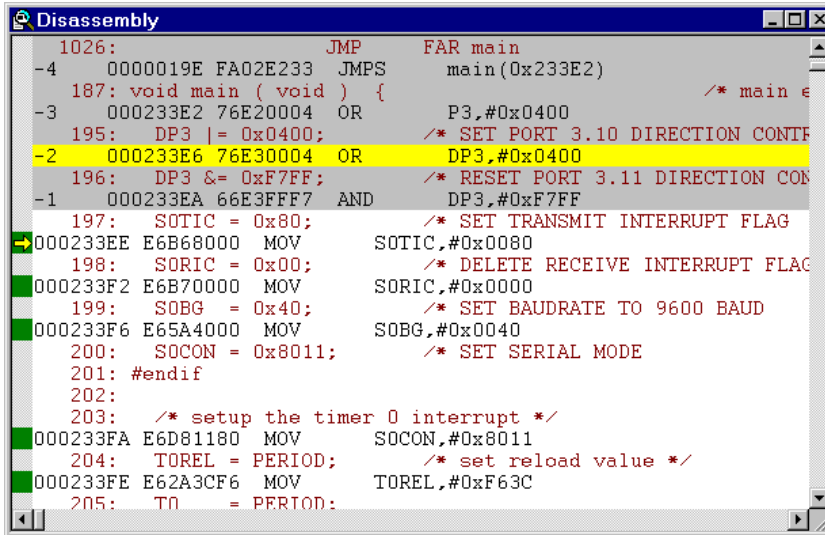

```

Disassembly
1026:                JMP     FAR main
-4: 0000019E FA02E233 JMPS   main(0x233E2)
187: void main ( void ) { /* main e
-3: 000233E2 76E20004 OR     P3,#0x0400
195: DP3 |= 0x0400; /* SET PORT 3.10 DIRECTION CONF
-2: 000233E6 76E30004 OR     DP3,#0x0400
196: DP3 &= 0xF7FF; /* RESET PORT 3.11 DIRECTION CON
-1: 000233EA 66E3FFF7 AND    DP3,#0xF7FF
197: SOTIC = 0x80; /* SET TRANSMIT INTERRUPT FLAG
->000233EE E6B68000 MOV    SOTIC,#0x0080
198: SORIC = 0x00; /* DELETE RECEIVE INTERRUPT FLAG
000233F2 E6B70000 MOV    SORIC,#0x0000
199: SOBG = 0x40; /* SET BAUDRATE TO 9600 BAUD
000233F6 E65A4000 MOV    SOBG,#0x0040
200: SOCON = 0x8011; /* SET SERIAL MODE
201: #endif
202:
203: /* setup the timer 0 interrupt */
000233FA E6D81180 MOV    SOCON,#0x8011
204: TOREL = PERIOD; /* set reload value */
000233FE E62A3CF6 MOV    TOREL,#0xF63C
205: T0 = PERIOD;
  
```

If you select the Disassembly Window as the active window all program step commands work on CPU instruction level rather than program source lines. You can select a text line and set or modify code breakpoints using toolbar buttons or the context menu commands.

You may use the dialog **Debug – Inline Assembly...** to modify the CPU instructions. That allows you to correct mistakes or to make temporary changes to the target program you are debugging.

Breakpoints

µVision2 lets you define breakpoints in several different ways. You may already set **Execution Breaks** during editing of your source text, even before the program code is translated. Breakpoints can be defined and modified in the following ways:

- With the **File Toolbar** buttons. Just select the code line in the **Editor** or **Disassembly** window and click on the breakpoint buttons.
- With the breakpoint commands in the local menu. The local menu opens with a right mouse click on the code line in the **Editor** or **Disassembly** window.
- The **Debug – Breakpoints...** dialog lets you review, define and modify breakpoint settings. This dialog allows you to define also access breakpoints with different attributes. Refer to the examples below.
- In the **Output Window – Command** page you can use the **BreakSet**, **BreakKill**, **BreakList**, **BreakEnable**, and **BreakDisable** commands.

The **Breakpoint** dialog lets you view and modify breakpoints. You can quickly disable or enable the breakpoints with a mouse click on the check box in the **Current Breakpoints** list. A double click in the **Current Breakpoints** list allows you to modify the selected break definition.

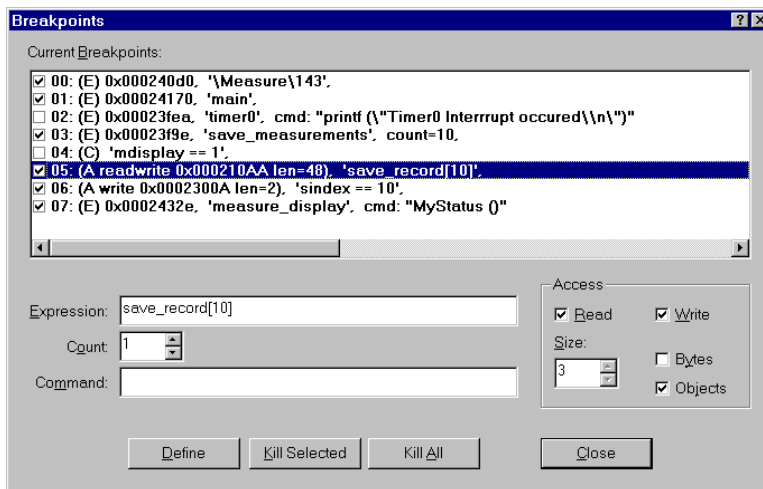

You define a breakpoint by entering an **Expression** in the Breakpoint dialog. Depending on the expression one of the following breakpoint types is defined:

- When the expression is a code address, an **Execution Break (E)** is defined that becomes active when the specified code address is reached. The code address must refer to the first byte of a CPU instruction.
- When a memory **Access** (Read, Write or both) is selected an **Access Break (A)** is defined that becomes active when the specified memory access occurs. You can specify the size of the memory access window in bytes or object size of the expression. Expressions for an **Access Break** must reduce to a memory address and memory type. The operators (&, &&, <, <=, >, >=, ==, and !=) can be used to compare the variable values before the **Access Break** halts program execution or executes the **Command**.
- When the expression cannot be reduced to an address a **Conditional Break (C)** is defined that becomes active when the specified conditional expression becomes true. The conditional expression is recalculated after each CPU instruction, therefore the program execution speed may slow down considerably.

When you specify a **Command** for a breakpoint, μ Vision2 executes the command and resumes executing your target program. The command you specify here may be a μ Vision2 debug or signal function. To halt program execution in a μ Vision2 function, set the `_break_` system variable. For more information refer to “System Variables” on page 113.

The **Count** value specifies the number of times the breakpoint expression is true before the breakpoint is triggered.

Breakpoint Examples:

The following description explains the definitions in the Breakpoint dialog shown above. The **Current Breakpoints** list summarizes the breakpoint type and the physical address along with the **Expression**, **Command** and **Count**.

```
Expression:  \Measure\143
```

Execution Break (E) that halts when the target program reaches the code line 143 in the module MEASURE.

```
Expression:  main
```

Execution Break (E) that halts when the target program reaches the **main** function.

```
Expression: timer0 Command: printf ("Timer0 Interrupt occurred\n")
```

Execution Break (E) that prints the text "Timer0 Interrupt occurred" in the **Output Window – Command** page when the target program reaches the **timer0** function. This breakpoint is disable in the above Breakpoint dialog.

```
Expression: save_measurements Count: 10
```

Execution Break (E) that halts when the target program reaches the function **save_measurements** the 10th time.

```
Expression: mcommand == 1
```

Contional Break (C) that halts program execution when the expression **mcommand == 1** becomes true. This breakpoint is disable in the above Breakpoint dialog.

```
Expression: save_record[10] Access: Read Write Size: 3 Objects
```

Access Break (A) that halts program execution when an read or write access occurs to **save_record[10]** and the following 2 objects. Since **save_record** is a structure with size 16 bytes this break defines an access region of 48 bytes.

```
Expression: sindex == 10 Access: Write
```

Access Break (A) that halts program execution when the value 10 is written to the variable **sindex**.

```
Expression: measure_display Command: MyStatus ()
```

Execution Break (E) that executes the μ Vision2 debug function **MyStatus** when the target program reaches the function **measure_display**. The target program execution resumes after the debug function **MyStatus** has been executed.

Target Program Execution

µVision2 lets execute your application program in several different ways:

- With the **Debug Toolbar** buttons and the “Debug Menu and Debug Commands” as described on page 28.
- With the **Run till Cursor line** command in the local menu. The local menu opens with a right mouse click on the code line in the **Editor** or **Disassembly** window.
- In the **Output Window – Command** page you can use the **Go**, **Ostep**, **Pstep**, and **Tstep** commands.

Watch Window

The Watch window lets you view and modify program variables and lists the current function call nesting. The contents of the Watch Window are automatically updated whenever program execution stops. You can enable **View – Periodic Window Update** to update variable values while a target program is running.

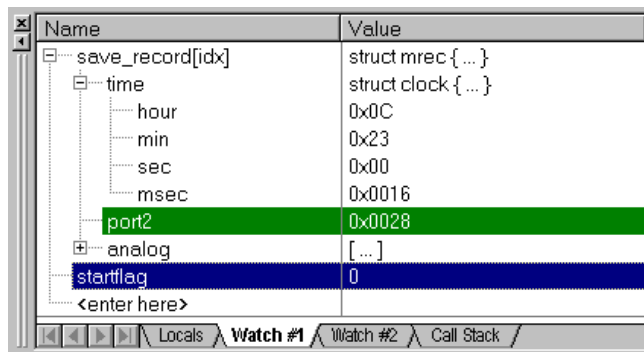

The **Locals** page shows all local function variables of the current function. The **Watch** pages display user-specified program variables. You add variables in three different ways:

- Select the text **<enter here>** with a mouse click and wait a second. Another mouse click enters edit mode that allows you to add variables. In the same way you can modify variable values.
- In an editor window open the context menu with a right mouse click and use **Add to Watch Window**. µVision2 automatically selects the variable name

under the cursor position, alternatively you may mark an expression before using that command.

- In the **Output Window – Command** page you can use the **WatchSet** command to enter variable names.

To remove a variable, click on the line and press the **Delete** key.

The current function call nesting is shown in the **Call Stack** page. You can double click on a line to show the invocation an editor window.



CPU Registers

The CPU registers are displayed and **Project Window – Regs** page and can be modified in the same way as variables in the **Watch Window**.



Memory Window

The Memory window displays the contents of the various memory areas. Up to four different areas can be review in the different pages. The context menu allows you to select the output format.

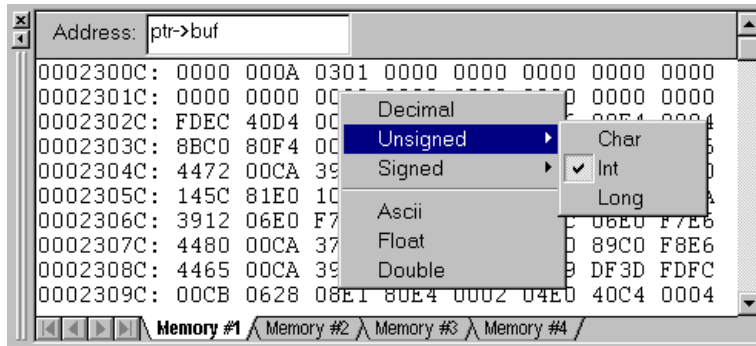

In the **Address** field of the Memory Window, you can enter any expression that evaluates to a start address of the area you want to display. To change the memory contents, double click on a value. This opens an edit box that allows you to enter new memory values. To update the memory window while a target program is running enable **View – Periodic Window Update**.

Toolbox

The **Toolbox** contains user-configurable buttons. Click on a **Toolbox** button to execute the associated command. Toolbox buttons may be executed at any time, even while running the test program.

Toolbox buttons are defined in the **Output Window – Command** page with the DEFINE BUTTON command. The general syntax is:

```
>DEFINE BUTTON "button_label", "command"
```

button_label is the name to display on the button in the Toolbox.

command is the μ Vision2 command to execute when the button is pressed.

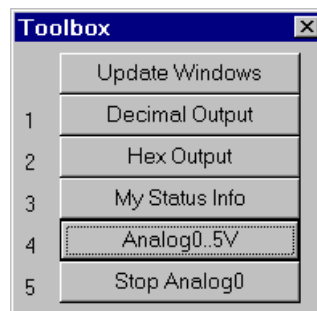

The following examples show the define commands used to create the buttons in the **Toolbox** shown above:

```
>DEFINE BUTTON "Decimal Output", "radix=0x0A"
>DEFINE BUTTON "Hex Output", "radix=0x10"
>DEFINE BUTTON "My Status Info", "MyStatus ()" /* call debug function */
>DEFINE BUTTON "Analog0.5V", "analog0 ()" /* call signal function */
>DEFINE BUTTON "Show R15", "printf (\ "R15=%04XH\n\ ")"
```

NOTE

The `printf` command defined in the last button definition shown above introduces nested strings. The double quote (") and backslash (\) characters of the format string must be escaped with \ to avoid syntax errors.

You may remove a **Toolbox** button with the **KILL BUTTON** command and the button number. For example:

```
>Kill Button 5 /* Remove Show R15 button */
```

NOTE

The **Update Windows** button in the Toolbox is created automatically and cannot be removed. The **Update Windows** button updates several debug windows during program execution.



Set Debug Options

The dialog **Options for Target - Debug** configures the μ Vision2 debugger.

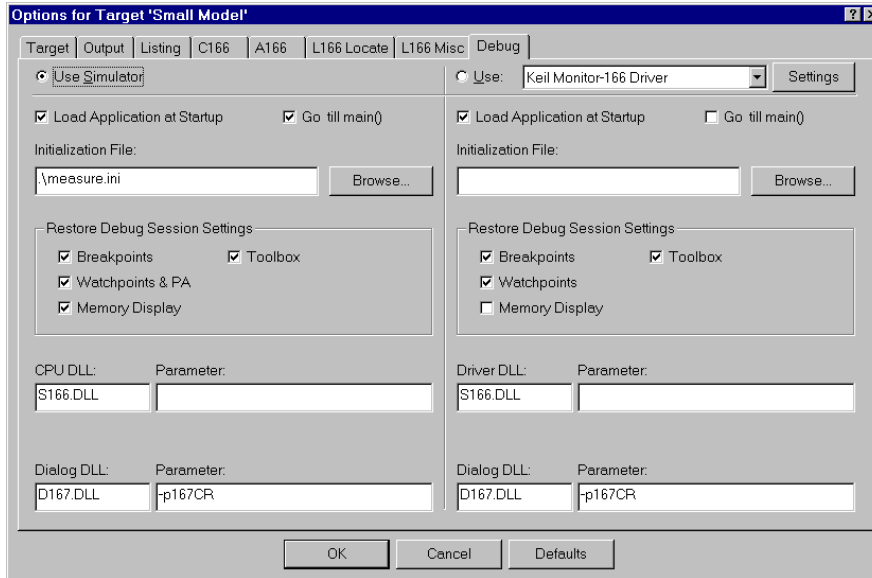

5

The following table describes the options of the **Debug** dialog page:

Dialog Item	Description
Use Simulator	Select the μ Vision2 Simulator as Debug engine.
Use Keil Monitor-51 Driver	Select the Advanced GDI driver to connect to your debug hardware. The Keil Monitor-51 Driver allows you to connect a target board with the Keil Monitor. There are μ Vision2 emulator and OCDS drivers in preparation.
Settings	Opens the configuration dialog of the selected Advanced GDI driver.
Other dialog options are available separately for the Simulator and Advanced GDI section.	
Load Application at Startup	Enable this option to load your target application automatically when you start the μ Vision2 debugger.
Go till main ()	Start program execution till the main label when you start the debugger.
Initialization File	Process the specified file as command input when starting a debug session.
Breakpoints	Restore breakpoint settings from the previous debug session.
Toolbox	Restore toolbox buttons from the previous debug session.
Watchpoints & PA	Restore Watchpoint and Performance Analyzer settings from the previous debug session.
Memory Display	Restore the memory display settings from the previous debug session.
CPU DLL Driver DLL Parameter	Configures the internal μ Vision2 debug DLLs. The settings are taken from the device database. Please do not modify the DLL or DLL parameters.

Serial Window

μ Vision2 provides two Serial Windows for serial input and output. Serial data output from the simulated CPU is displayed in this window. Characters you type in the **Serial Window** are input to the simulated CPU.

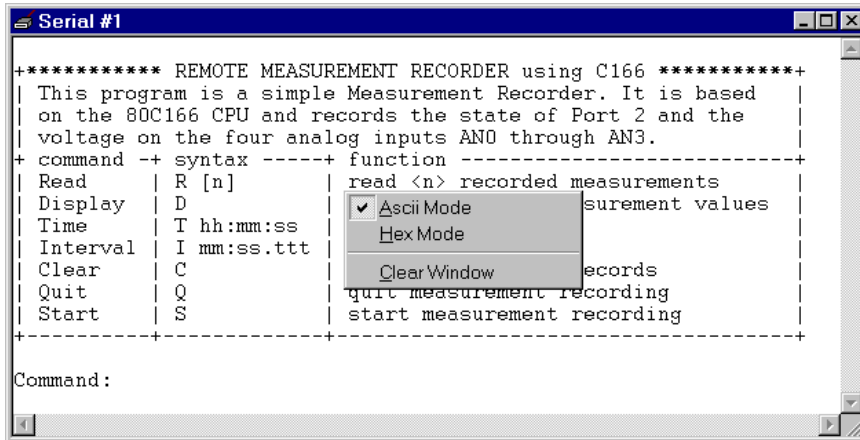

This lets you simulate the CPU's UART without the need for external hardware. The serial output may be also assigned to a PC COM port using the ASSIGN command in the **Output Window – Command** page.

5

Performance Analyzer

The μ Vision2 Performance Analyzer displays the execution time recorded for functions and address ranges you specify.

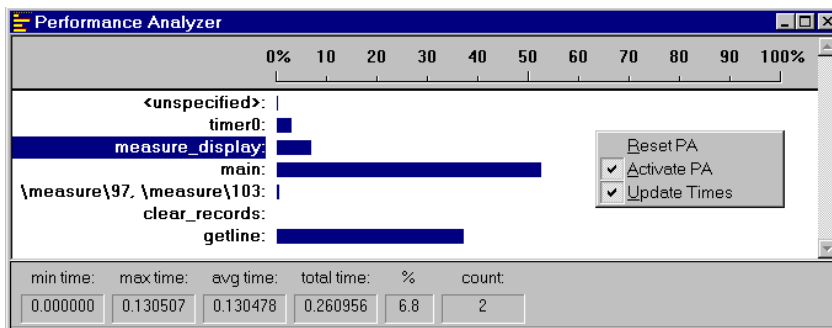

The **<unspecified>** address range is automatically generated. It shows the amount of time spent executing code that is not included in the specified functions or address ranges.

Results display as bar graphs. Information such as invocation count, minimum time, maximum time, and average time is displayed for the selected function or address range. Each of these statistics is described in the following table.

Label	Description
min time	The minimum time spent in the selected address range or function.
max time	The maximum time spent in the selected address range or function.
avg time	The average time spent in the selected address range or function.
total time	The total time spent in the selected address range or function.
%	The percent of the total time spent in the selected address range or function.
count	The total number of times the selected address range or function was executed.

To setup the Performance Analyzer use the menu command **Debug – Performance Analyzer**. You may enter the **PA** command in the command window to setup ranges or print results.

5



Code Coverage

The μ Vision2 debugger provides a code coverage function that marks the code that has been executed. In the debug window, lines of code that have been executed are marked green in the left column. You can use this feature when you test your embedded application to determine the sections of code that have not yet been exercised.

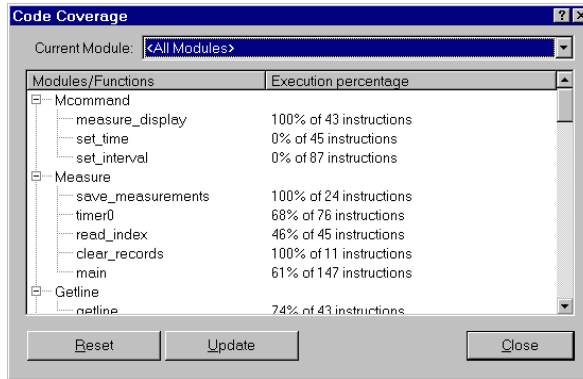

The Code Coverage dialog provides information and statistics. You can output this information in the **Output Window – Command page** using the **COVERAGE** command.

Memory Map

The Memory Map dialog box lets you specify the memory areas your target program uses for data storage and program execution. You may also configure the target program's memory map using the **MAP** command.

When you load a target application, μ Vision2 automatically maps all address ranges of your application. Typically it is not required to map additional address ranges. You need to map only memory areas that are accessed without explicit variable declarations, i.e. memory mapped I/O space.

The dialog opens via the menu **Debug – Memory Map...**

As your target program runs, μ Vision2 uses the memory map to verify that your program does not access invalid memory areas. For each memory range, you may specify the access method: **Read**, **Write**, **Execute**, or a combination.

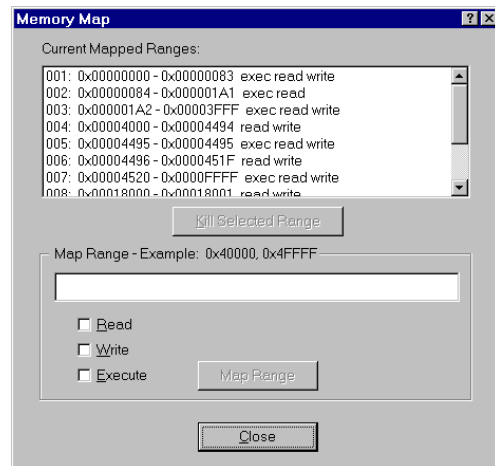

View – Symbols Window

The Symbols Window displays public symbols, local symbols, line number information, and CPU-specific SFRs defined in the currently loaded application.

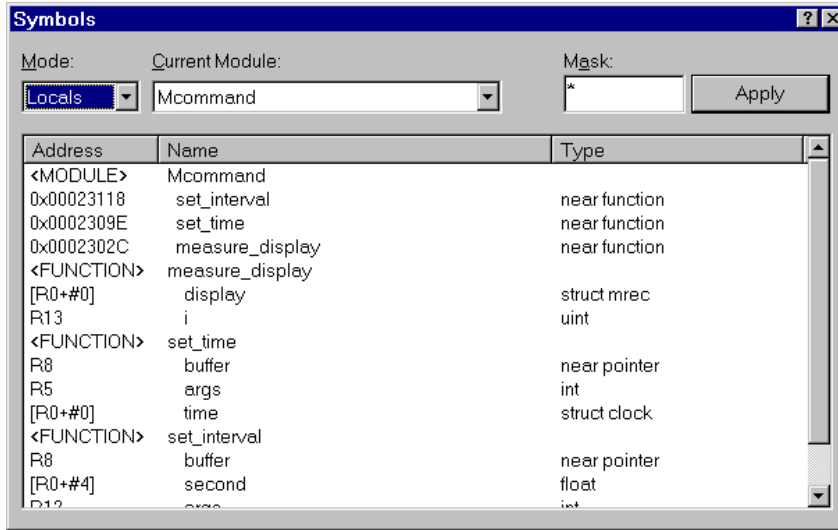

5

You may select the symbol type and filter symbols displayed.

Options	Description
Mode	select PUBLIC, LOCALS or LINE. Public symbols have application-wide scope. The scope of local symbols is limited to a module or function. Lines refer to the line number information of the source text.
Current Module	select the source module where information should be displayed.
Mask	specify a mask that is used to match symbol names. The mask may consist of alphanumeric characters plus mask characters: # matches a digit (0 – 9) \$ matches any character * matches zero or more characters.
Apply	applies the mask and displays the update symbol list.

The following table provides a few examples of masks for symbol name.

Mask	Matches symbol names ...
*	Matches any symbol. This is the default mask in the Symbol Browser.
*##	... that contain one digit in any position.
<u>_a\$#</u> *	... with an underline, followed by the letter a , followed by any character, followed by a digit, ending with zero or more characters. For example, _ab1 or _a10value .
<u>_*</u> ABC	... with an underline, followed by zero or more characters, followed by ABC .

Debug Commands

You may interact with the μ Vision2 debugger by entering commands in the **Output Window – Command** page. In the following tables all available μ Vision2 debug commands are listed in categories. Use the underlined characters in the command names to enter commands. For example, the **WATCHSET** command must be entered as **WS**.

During command entry, the syntax generator displays possible commands, options and parameters. As you enter commands μ Vision2 reduces the list of likely commands to coincide with the characters you type.

If you type **B**, the syntax generator reduces the commands listed.

```
>B
BreakDisable BreakEnable BreakKill BreakList BreakSet
|<< >>| Build | Command | Find in Files |
```

Available command options are listed if the command is clear.

```
>BS
READ WRITE READWRITE <break expression>
|<< >>| Build | Command | Find in Files |
```

The syntax generator leads you through the command entry and helps you to avoid errors.

```
>BS WRITE saverecords[0], 1, "_break_ = 1"
"<command>" <cr>
|<< >>| Build | Command | Find in Files |
```

Memory Commands

The following memory commands let you display and alter memory contents.

Command	Description
<u>A</u>SM	Assembles in-line code.
<u>D</u>EFINE	Defines typed symbols that you may use with μ Vision2 debug functions.
<u>D</u>ISPLAY	Display the contents of memory.
<u>E</u>NTER	Enters values into a specified memory area.
<u>E</u>VALUATE	Evaluates an expression and outputs the results.
<u>M</u>AP	Specifies access parameters for memory areas.
<u>U</u>NASSEMBLE	Disassembles program memory.
<u>W</u>ATCHSET	Adds a watch variable to the Watch window.

Program Execution Commands

Program commands let you run code and step through your program one instruction at a time.

5

Command	Description
Esc	Stops program execution.
<u>G</u>O	Starts program execution.
<u>P</u>STEP	Steps over instructions but does not step into procedures or functions.
<u>O</u>STEP	Steps out of the current function.
<u>I</u>STEP	Steps over instructions and into functions.

Breakpoint Commands

μ Vision2 provides breakpoints you may use to conditionally halt the execution of your target program. Breakpoints can be set on read operations, write operations and execution operations.

Command	Description
<u>B</u>BREAKDISABLE	Disables one or more breakpoints.
<u>B</u>BREAKENABLE	Enables one or more breakpoints.
<u>B</u>BREAKKILL	Removes one or more breakpoints from the breakpoint list.
<u>B</u>BREAKLIST	Lists the current breakpoints.
<u>B</u>BREAKSET	Adds a breakpoint expression to the list of breakpoints.

General Commands

The following general commands do not belong in any other particular command group. They are included to make debugging easier and more convenient.

Command	Description
<u>ASSIGN</u>	Assigns input and output sources for the Serial window.
<u>COVERAGE</u>	List code coverage statistics.
<u>DEFINE BUTTON</u>	Creates a Toolbox button.
<u>DIR</u>	Generates a directory of symbol names.
<u>EXIT</u>	Exits the μ Vision2 debug mode.
<u>INCLUDE</u>	Reads and executes the commands in a command file.
<u>KILL</u>	Deletes μ Vision2 debug functions and Toolbox buttons.
<u>LOAD</u>	Loads CPU drivers, object modules, and HEX files.
<u>LOG</u>	Creates log files, queries log status, and closes log files for the Debug window.
<u>MODE</u>	Sets the baud rate, parity, and number of stop bits for PC COM ports.
<u>PerformanceAnalyze</u>	Setup the performance analyzer or list PA information.
<u>RESET</u>	Resets CPU, memory map assignments, Performance Analyzer or predefined variables.
<u>SAVE</u>	Saves a memory range in an Intel HEX386 file.
<u>SCOPE</u>	Displays address assignments of modules and functions of a target program.
<u>SET</u>	Sets the string value for predefined variable.
<u>SETMODULE</u>	Assigns a source file to a module.
<u>SIGNAL</u>	Displays signal function status and removes active signal functions.
<u>SLOG</u>	Creates log files, queries log status, and closes log files for the Serial window.

You can interactively display and change variables, registers, and memory locations from the command window. For example, you can type the following text commands at the command prompt:

Text	Effect
MDH	Display the MDH register.
R7 = 12	Assign the value 12 to register R7 .
time.hour	Displays the member hour of the time structure.
time.hour++	Increments the member hour of the time structure.
index = 0	Assigns the value 0 to index .

Expressions

Many debug commands accept numeric expressions as parameters. A numeric expression is a number or a complex expressions that contains numbers, debug objects, or operands. An expression may consist of any of the following components.

Component	Description
Bit Addresses	Bit addresses reference bit-addressable data memory.
Constants	Constants are fixed numeric values or character strings.
Line Numbers	Line numbers reference code addresses of executable programs. When you compile or assemble a program, the compiler and assembler include line number information in the generated object module.
Operators	Operators include +, -, *, and /. Operators may be used to combine subexpressions into a single expression. You may use all operators that are available in the C programming language.
Program Variables (Symbols)	Program variables are those variables in your target program. They are often called symbols or symbolic names.
System Variables	System variables alter or affect the way μ Vision2 operates.
Type Specifications	Type specifications let you specify the data type of an expression or subexpression.

Constants

The μ Vision2 accepts decimal constants, HEX constants, octal constants, binary constants, floating-point constants, character constants, and string constants.

Binary, Decimal, HEX, and Octal Constants

By default, numeric constants are decimal or base ten numbers. When you enter 10, this is the number ten and not the HEX value 10_h. The following table shows the prefixes and suffixes that are required to enter constants in base 2 (binary), base 8 (octal), base 10 (decimal), and base 16 (HEX).

Base	Prefix	Suffix	Example
Binary:	None	Y or y	11111111Y
Decimal:	None	T or none	1234T or 1234
Hexadecimal:	0x or 0X	H or h	1234H or 0x1234
Octal:	None	Q , q , O , or o	777q or 777Q or 777o

Following are a few points to note about numeric constants.

- Numbers may be grouped with the dollar sign character (“\$”) to make them easier to read. For example, 1111\$1111_y is the same as 11111111_y.
- HEX constants must begin prefixed with a leading zero when the first digit in the constant is A-F.
- By default, numeric constants are 16-bit values. They may be followed with an **L** to make them long, 32-bit values. For example: **0x1234L**, **1234L**, **1255HL**.
- When a number is entered that is larger than the range of a 16-bit integer, the number is promoted automatically to a 32-bit integer.

Floating-Point Constants

Floating-point constants are entered in one of the following formats.

number . number

number e $[+|-]$ *number*

number . number $[e [+|-]$ *number* $]$

For example, 4.12, 0.1e3, and 12.12e-5. In contrast with the C programming language, floating-point numbers must have a digit before the decimal point. For example, .12 is not allowed. It must be entered as 0.12.

Character Constants

The rules of the C programming language for character constants apply to the μ Vision2 debugger. For example, the following are all valid character constants.

```
'a', '1', '\n', '\v', '\x0FE', '\015'
```

Also escape sequences are supported as listed in the following table:

5

Sequence	Description
\\	Backslash character (“\”).
\"	Double quote.
'	Single quote.
\a	Alert, bell.
\b	Backspace.
\f	Form feed.

Sequence	Description
\n	Newline.
\r	Carriage return.
\t	Tab.
\0nn	Octal constant.
\Xnnn	HEX constant.

String Constants

The rules of the C programming language for string constants also apply to μ Vision2. For example:

```
"string\x007\n"                                "value of %s = %04XH\n"
```

Nested strings may be required in some cases. For example, double quotes for a nested string must be escaped. For example:

```
"printf (\\"hello world!\n\")"
```

In contrast with the C programming language, successive strings are not concatenated into a single string. For example, "string1+" "string2" is not combined into a single string.

System Variables

System variables allow access to specific functions and may be used anywhere a program variable or other expression is used. The following table lists the available system variables, the data types, and their uses.

Variable	Type	Description
\$	unsigned long	Represents the program counter. You may use \$ to display and change the program counter. For example, \$ = C:0x4000 sets the program counter to address C:0x4000.
break	unsigned int	Allows you to stop executing the target program. When you set _break_ to a non-zero value, μ Vision2 halts target program execution. You may use this variable in user and signal functions to halt program execution. Refer to "Chapter 6. μ Vision2 Debug Functions" on page 131 for more information.
iip	unsigned char	Indicates the number of interrupts that are currently nested. Debug functions may use this system variable to determine if an interrupt is currently in process.
states	unsigned long	Current value of the CPU instruction state counter; starts counting from 0 when your target program begins execution and increases for each instruction that is executed. NOTE: <i>states</i> is a read-only variable.
itrace	unsigned int	Indicates whether or not trace recording is performed during target program execution. When itrace is 0, no trace recording is performed. When itrace has a non-zero value, trace information is recorded. Refer to page 95 for more information.
radix	unsigned int	Determines the base used for numeric values displayed. radix may be 10 or 16. The default setting is 16 for HEX output.

On-chip Peripheral Symbols

μ Vision2 automatically defines a number of symbols depending on the CPU you have selected for your project. There are two types of symbols that are defined: special function registers (SFRs) and CPU pin registers (VTREGs).

Special Function Registers (SFRs)

μ Vision2 supports all special function registers of the microcontroller you have selected. Special function registers have an associated address and may be used in expressions.

CPU Pin Registers (VTREGs)

CPU pin registers, or VTREGs, let you use the CPU's simulated pins for input and output. VTREGs are not public symbols nor do they reside in a memory space of the CPU. They may be used in expressions, but their values and utilization are CPU dependent. VTREGs provide a way to specify signals coming into the CPU from a simulated piece of hardware. You can list these symbols with the **DIR VTREG** command.

The following table describes the VTREG symbols. The VTREG symbols that are actually available depend on the selected CPU.

VTREG	Description
AINx	An analog input pin on the chip. Your target program may read values you write to AINx VTREGs.
CLOCK	The internal CPU clock frequency; specifies the number of instruction states executed within one second in the target CPU. The system variable states and the VTREG CLOCK are used to calculate the CPU execution time in seconds. CLOCK is read-only and derived from the XTAL frequency entry in the Options – Target dialog.
PORTx	A group of I/O pins for a port on the chip. For example, PORT2 refers to all 8 or 16 pins of P2. These registers allow you to simulate port I/O.
SxIN	The input buffer of serial interface x . You may write 8-bit or 9-bit values to SxIN . These are read by your target program. You may read SxIN to determine when the input buffer is ready for another character. The value 0xFFFF signals that the previous value is completely processed and a new value may be written.
SxOUT	The output buffer of serial interface x . μ Vision2 copies 8-bit or 9-bit values (as programmed) to the SxOUT VTREG.
SxTIME	Defines the baudrate timing of the serial interface x . When SxTIME is 1, μ Vision2 simulates the timing of the serial interface using the programmed baudrate. When SxTIME is 0 (the default value), the programmed baudrate timing is ignored and serial transmission time is instantaneous.
XTAL	The XTAL frequency of the simulated CPU as defined in the Options – Target dialog.

NOTE

You may use the VTREGs to simulate external input and output including interfacing to internal peripherals like interrupts and timers. For example, if you toggle bit 2 of PORT3 (on the 8051 drivers), the CPU driver simulates external interrupt 0.

For the C517 CPU the following VTREG symbols for the on-chip peripheral registers are available:

CPU-pin Symbol	Description
AIN0	Analog input line AIN0 (floating-point value)
AIN1	Analog input line AIN1 (floating-point value)
AIN2	Analog input line AIN2 (floating-point value)
AIN3	Analog input line AIN3 (floating-point value)
AIN4	Analog input line AIN4 (floating-point value)
AIN5	Analog input line AIN5 (floating-point value)
AIN6	Analog input line AIN6 (floating-point value)
AIN7	Analog input line AIN7 (floating-point value)
AIN8	Analog input line AIN8 (floating-point value)
AIN9	Analog input line AIN9 (floating-point value)
AIN10	Analog input line AIN10 (floating-point value)
AIN11	Analog input line AIN11 (floating-point value)
CLOCK	Internal CPU clock frequency for instruction execution
PORT0	Digital I/O lines of PORT 0 (8-bit)
PORT1	Digital I/O lines of PORT 1 (8-bit)
PORT2	Digital I/O lines of PORT 2 (8-bit)
PORT3	Digital I/O lines of PORT 3 (8-bit)
PORT4	Digital I/O lines of PORT 4 (8-bit)
PORT5	Digital I/O lines of PORT 5 (8-bit)
PORT6	Digital I/O lines of PORT 6 (8-bit)
PORT7	Digital I/O lines of PORT 7 (8-bit)
PORT8	Digital I/O lines of PORT 8 (8-bit)
S0IN	Serial input for SERIAL CHANNEL 0 (9-bit)
S0OUT	Serial output for SERIAL CHANNEL 0 (9-bit)
S1IN	Serial input for SERIAL CHANNEL 1 (9-bit)
S1OUT	Serial output for SERIAL CHANNEL 1 (9-bit)
STIME	Serial timing enable
VAGND	Analog reference voltage VAGND (floating-point value)
VAREF	Analog reference voltage VAREF (floating-point value)
XTAL	Oscillator frequency

The following examples show how VTREGs may be used to aid in simulating your target program. In most cases, you use VTREGs in signal functions to simulate some part of your target hardware.

I/O Ports

μ Vision2 defines a VTREG for each I/O port: i.e. **PORT2**. Do not confuse these VTREGs with the SFRs for each port (i.e. **P2**). The SFRs can be accessed inside the CPU memory space. The VTREGs are the signals present on the pins.

With μ Vision2, it is easy to simulate input from external hardware. If you have a pulse train coming into a port pin, you can use a signal function to simulate the signal. For example, the following signal function inputs a square wave on P2.1 with a frequency of 1000Hz.

```
signal void one_thou_hz (void) {
    while (1) {
        PORT2 |= 1;
        twatch ((CLOCK / 2) / 2000);
        PORT2 &= ~1;
        twatch ((CLOCK / 2) / 2000);
    }
}
```

The following command starts this signal function:

```
one_thou_hz ()
```

Refer to “Chapter 6. μ Vision2 Debug Functions” on page 131 for more information about user and signal functions.

Simulating external hardware that responds to output from a port pin is only slightly more difficult. Two steps are required. First, write a μ Vision2 user or signal function to perform the desired operations. Second, create a breakpoint that invokes the user function.

Suppose you use an output pin (P2.0) to enable or disable an LED. The following signal function uses the **PORT2** VTREG to check the output from the CPU and display a message in the Command window.

```
signal void check_p20 (void) {
    if (PORT2 & 1) {
        printf ("LED is ON\n");
    } else {
        printf ("LED is OFF\n");
    }
}
```

Now, you must add a breakpoint for writes to port 1. The following command line adds a breakpoint for all writes to PORT2.

```
BS WRITE PORT2, 1, "check_p20 ()"
```

Now, whenever your target program writes to PORT2, the `check_P20` function prints the current status of the LED. Refer to page 96 for more information about setting breakpoints.

Serial Ports

The on-chip serial port is controlled with: **S0TIME**, **S0IN**, and **S0OUT**. **S0IN** and **S0OUT** represent the serial input and output streams on the CPU. **S0TIME** lets you specify whether the serial port timing is instantaneous (**STIME** = 0) or the serial port timing is relative to the specified baudrate (**SxTIME** = 1). When **S0TIME** is 1, serial data displayed in the Serial window is output at the specified baudrate. When **S0TIME** is 0, serial data is displayed in the Serial window much more quickly.

Simulating serial input is just as easy as simulating digital input. Suppose you have an external serial device that inputs specific data periodically (every second). You can create a signal function that feeds the data into the CPU's serial port.

```
signal void serial_input (void) {
    while (1) {                               /* repeat forever */
        twatch (CLOCK);                       /* Delay for 1 second */

        S0IN = 'A';                            /* Send first character */
        twatch (CLOCK / 900);                 /* Delay for 1 character time */
                                                /* 900 is good for 9600 baud */
        S0IN = 'B';                            /* Send next character */
        twatch (CLOCK / 900);
        S0IN = 'C';                            /* Send final character */
    }                                           /* repeat */
}
```

When this signal function runs, it delays for 1 second, inputs 'A', 'B', and 'C' into the serial input line and repeats.

Serial output is simulated in a similar fashion using a user or signal function and a write access breakpoint as described above.

Program Variables (Symbols)

µVision2 lets you access variables, or symbols, in your target program by simply typing their name. Variable names, or symbol names, represent numeric values and addresses. Symbols make the debugging process easier by allowing you to use the same names in the debugger as you use in your program.

When you load a target program module and the symbol information is loaded into the debugger. The symbols include local variables (declared within functions), the function names, and the line number information. You must enable **Options for Target – Output – Debug Information**. Without debug information, µVision2 cannot perform source-level and symbolic debugging.

Module Names

A module name is the name of an object module that makes up all or part of a target program. Source-level debugging information as well as symbolic information is stored in each module.

The module name is derived from the name of the source file. If the target program consists of a source file named **MCOMMAND.C** and the C compiler generates an object file called **MCOMMAND.OBJ**, the module name is **MCOMMAND**.

5

Symbol Naming Conventions

The following conventions apply to symbols.

- The case of symbols is ignored: **SYMBOL** is equivalent to **Symbol**.
- The first character of a symbol name must be: ‘A’-‘Z’, ‘a’-‘z’, ‘_’, or ‘?’.
- Subsequent characters may be: ‘A’-‘Z’, ‘a’-‘z’, ‘0’-‘9’, ‘_’, or ‘?’.

NOTE

*When using the ternary operator (“?:”) in µVision2 with a symbol that begins with a question mark (“?”), you must insert a space between the ternary operator and the symbol name. For example, **R5 = R6 ? ?symbol : R7**.*

Fully Qualified Symbols

Symbols may be entered using a fully qualified name that includes the name of the module and name of the function in which the symbol is defined. A fully qualified symbol name is composed of the following components:

- **Module Name** identifies the module where a symbol is defined.
- **Line Number** identifies the address of the code generated for a particular line in the module.
- **Function Name** identifies the function in a module where a local symbol is defined.
- **Symbol Name** identifies the name of the symbol.

This components may combined as shown in the following table:

Symbol Components	Full Qualified Symbol Name addresses ...
<code>\ModuleName\LineNumber</code>	... line number <i>LineNumber</i> in <i>ModuleName</i> .
<code>\ModuleName\FunctionName</code>	... <i>FunctionName</i> function in <i>ModuleName</i> .
<code>\ModuleName\SymbolName</code>	... global symbol <i>SymbolName</i> in <i>ModuleName</i> .
<code>\ModuleName\FunctionName\SymbolName</code>	... local symbol <i>SymbolName</i> in the <i>FunctionName</i> function in <i>ModuleName</i> .

Examples of fully qualified symbol names:

Full Qualified Symbol Name	Identifies ...
<code>\MEASURE\clear_records\idx</code>	... local symbol <i>idx</i> in the <i>clear_records</i> function in the MEASURE module.
<code>\MEASURE\MAIN\cmdbuf</code>	... <i>cmdbuf</i> local symbol in the MAIN function in the MEASURE module.
<code>\MEASURE\sindx</code>	... <i>sindex</i> symbol in the MEASURE module.
<code>\MEASURE\225</code>	... line number 225 in the MEASURE module.
<code>\MCOMMAND\82</code>	... line number 82 in the MCOMMAND module.
<code>\MEASURE\TIMER0</code>	... the TIMER0 symbol in the MEASURE module. This symbol may be a function or a global variable.

Non-Qualified Symbols

Symbols may be entered using the only name of the variable or function they reference. These symbols are not fully qualified and searched in a number of tables until a matching symbol name is found. This search works as follows:

1. **Register Symbols** of the CPU: R0 – R15, RL0 – RH7, DPP0 – DPP3.
2. **Local Variables in the Current Function** in the target program. The current function is determined by the value of the program counter.
3. **Static Variables in the Current Module.** As with the current function, the current module is determined by the value of the program counter. Symbols in the current module represent variables that were declared in the module but outside a function.
4. **Global or Public Symbols** of your target program. SFR symbols defined by μ Vision2 are considered to be public symbols and are also searched.
5. **Symbols Created with the μ Vision2 DEFINE Command.** These symbols are used for debugging and are not a part of the target program.
6. **System Variables** that monitor and change debugger characteristics. They are not a part of the target program. Refer to “System Variables” on page 113 for more information.
7. **CPU Driver Symbols (VTREGs)** defined by the CPU driver. Refer to “CPU Pin Registers (VTREGs)” on page 114 for a description of VTREG symbols.

5

NOTES

The search order for symbols changes when creating user or signal functions. μ Vision2 first searches the table of symbols defined in the user or signal function. Then, the above list is searched. Refer to “Chapter 6. μ Vision2 Debug Functions” on page 131 for more information about user and signal functions.

*A literal symbol that is preceded with a back quote character (‘) modifies the search order: **CPU driver symbols (VTREGs)** are searched instead of **CPU register symbols**.*

Literal Symbols

With the back quote character (`) you get a literal symbol name. Literal symbols must be used to access:

- A program variable or symbol which is identical with a predefined **Reserved Word**. **Reserved Words** are μ Vision2 debug commands & options, data type names, CPU register names and assembler mnemonics.
- A CPU driver symbol (VTREG) that is identical to program variable name.

If a literal symbol name is given, μ Vision2 changes the search order for non-qualified symbols that is described above. For a literal symbol **CPU Driver Symbols (VTREGs)** are searched instead of **CPU Register Symbols**.

Examples for using Literal Symbols

If you define a variable named **R5** in your program and you attempt to access it, you will actually access the **R5** CPU register. To access the **R5** variable, you must prefix the variable name with the back quote character.

Accessing the R5 Register

```
>R5 = 121
```

Accessing the R5 Variable

```
>`R5 = 212
```

If your program contains a function named **clock** and you attempt to **clock** VTREG, you will get the address of the **clock** function. To access the **clock** VTREG, you must prefix the variable name with the back quote character.

Accessing the *clock* function

```
>clock  
0x00000DB2
```

Accessing the clock VTREG

```
>`clock  
20000000
```

Line Numbers

Line numbers enable source-level debugging and are produced by the compiler or assembler. The line number specifies the physical address in the source module of the associated program code. Since a line number represents a code address, μ Vision2 lets you use in an expression. The syntax for a line number is shown in the following table.

Line Number Symbol	Code Address ...
<code>\LineNumber</code>	... for line number <i>LineNumber</i> in the current module.
<code>\ModuleName\LineNumber</code>	... for line number <i>LineNumber</i> in <i>ModuleName</i> .

Example

```
\measure\108          /* Line 108 in module "MEASURE" */
\143                  /* Line 143 in the current module */
```

Bit Addresses

Bit addresses represent bits in the memory. This includes bits in special function registers. The syntax for a bit address is *expression . bit_position*

Examples

```
ACC.2                /* Bit 2 of register A */
0x20.5               /* Value of the 8051 bit space */
```

Memory Spaces

The 8051 microcontrollers provide different memory areas for variables and program code. These memory areas are reflected in the prefixes that might be used with expressions. The prefixes available are listed in the following table.

Prefix	Memory Space	Description
B:	BIT	Bit-addressable RAM.
C:	CODE	Code Memory.
Bx:	CODE BANK	Code Memory Bank; x specifies a bank number, example B1:
D:	DATA	Internal, directly-addressable RAM.
I:	IDATA	Internal, indirectly-addressable RAM.
X:	XDATA	Xdata RAM.

NOTE

Prefixes are not necessary with symbols since symbolic names typically have an associated memory space.

Examples

```
C:0x100      /* Address 0x100 in code memory */
I:100       /* Address 0x64 in internal RAM of the 8051 */
X:0FFFFH    /* Address 0xFFFF in the external data memory */
B:0x7F      /* Bit address 127 or 2FH.7 */
B2:0x9000   /* Address 0x9000 in code bank 2 */
```

5

Type Specifications

μ Vision2 automatically performs implicit type casting in an expression. You may explicitly cast expressions to specific data types. Type casting follows the conventions used in the C programming language. Example:

```
(unsigned int) 31.2 /* gives unsigned int 31 from the float value */
```

Operators

μ Vision2 supports all operators of the C programming language. The operators have the same meaning as their C equivalents.

Differences Between μ Vision2 and C

There are a number of differences between expressions in μ Vision2 and expressions in the C programming language:

- μ Vision2 does not differentiate between uppercase and lowercase characters for symbolic names and command names.
- μ Vision2 does not support converting an expression to a typed pointer like **char *** or **int ***. Pointer types are obtained from the symbol information in the target program. They cannot be created.
- Function calls entered in the μ Vision2 Output Window – Command page refer to debug functions. You cannot invoke functions in your target from the command line. Refer to “Chapter 6. μ Vision2 Debug Functions” on page 131 for more information.
- μ Vision2 does not support structure assignments.

Expression Examples

The following expressions were entered in the Command page of the Output Window. All applicable output is included with each example. The MEASURE example program was used for all examples.

5

Constant

```
>0x1234 /* Simple constant */
0x1234 /* Output */
>EVAL 0x1234
4660T 11064Q 1234H '...4' /* Output in several number bases */
```

Register

```
>R1 /* Interrogate value of register R1 */
0x000A /* Address from ACC = 0xE0, mem type = D: */
>R1 = --R7 /* Set R1 and R7 equal to value R7-1 */
```

Function Symbol

```
>main /* Get address of main() from MEASURE.C */
0x00233DA /* Reply, main starts at 0x233DA */

>&main /* Same as before */
0x00233DA

>d main /* Display: address = main */
0x0233DA: 76 E2 00 04 76 E3 00 04 - 66 E3 FF F7 E6 B6 80 00 v...v...f.....
0x0233EA: E6 B7 00 00 E6 5A 40 00 - E6 D8 11 80 E6 2A 3C F6 .....Z@.....*<
```

```
0x0233FA: E6 28 3C F6 E6 CE 44 00 - BF 88 E6 A8 40 00 BB D8 .(<...D.....@..
0x02340A: E6 F8 7A 40 CA 00 CE 39 - E6 F8 18 44 CA 00 CE 39 ..z@...9...D...
```

Address Utilization Examples

```
>&\measure\main\cmdbuf[0] + 10 /* Address calculation */
0x23026

>_RBYTE (0x233DA) /* Read byte from code address 0x233DA */
0x76 /* Reply */
```

Symbol Output Examples

```
>dir \measure\main /* Output symbols from main() in module MEASURE */
R14 idx . . . uint /* Output */
R13 i . . . uint
0x0002301C cmdbuf . . . array[15] of char
```

Program Counter Examples

```
>$ = main /* Set program counter to main() */
>dir /* points to local mem sym. from main() */
R14 idx . . . uint /* Output */
R13 i . . . uint
0x0002301C cmdbuf . . . array[15] of char
```

Program Variable Examples

```
>cmdbuf /* Interrogate address from cmdbuf */
0x0002301C /* Output of address due to aggregate type (Array)*/
>cmdbuf[0] /* Output contents of first array element */
0x00
>I /* Output contents from i */
0x00
>idx /* Output contents from idx */
0x0000
>idx = DPP2 /* Set contents from index equal to register DPP2 */
>idx /* Output contents from idx */
0x0008
```

Line Number Examples

```
>\163 /* Address of the line number #104 */
0x000230DA /* Reply */
>\MCOMMAND\91 /* A line number of module "MCOMMAND" */
0x000231F6
```

Operator Examples

```
>--R5 /* Auto-decrement also for CPU registers */
0xFE
>mdisplay /* Output a PUBLIC bit variable */
0
>mdisplay = 1 /* Change */
>mdisplay /* Check result */
1
```

Structure Examples

```
>save_record[0] /* Address of a record */
0x002100A
>save_record[0].time.hour = DPP3 /* Change struct element of records */

>save_record[0].time.hour /* Interrogation */
0x03
```

µVision2 Debug Function Invocation Examples

```
>printf ("uVision2 is coming!\n") /* String constant within printf() */
uVision2 is coming! /* Output */
>_WBYTE(0x20000, _RBYTE(0x20001)) /* Read & Write Memory Byte */
> /* example useful in debug functions */
>interval.min = getint ("enter integer: ");
```

Fully Qualified Symbol Examples

```
>--\measure\main\idx /* Auto INC/DEC valid for qualified symbol */
0xFFFF
```

Tips and Tricks

The following section discusses advanced techniques that you may use with the µVision2 debugger. You will not need the following features very often, but readers of this section get a better feeling for the µVision2 debugger capabilities.

5

Simulating I/O Ports

µVision2 provides dialogs that show the status of all I/O ports. The I/O Pins are represented with VTREGs. You may use this VTREGs also together with signal functions or breakpoints as shown in the following example program.

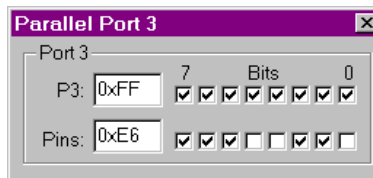

```
// in your C user program
p1value = P1; // read Port 1 input
P3 = p1value; // write to Port 3
```

Breakpoints that you define in the µVision2 simulator:

```
bs write PORT3, 1, "printf (\\"Port3 value=%X\\n\\", PORT3)"
bs read PORT1, 1, "PORT1 = getint (\\"Input Port1 value\\")"
```

When you execute your C program, µVision2 asks you for a Port1 input value. If a new

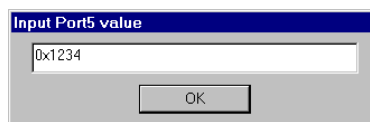

output value is written to Port3, a message is printed in the **Output Window - Command** page. Refer also to “CPU Pin Registers (VTREGs)” on page 114.

Simulating Interrupts and Clock Inputs

µVision2 simulates the behavior of the I/O inputs. If an I/O pin is configured as counter input the count value increments when the pin toggles. The following example shows how to simulate input for Counter 3:

```
// in your C user program
T3CON = 0x004B; // set T3 Counter Mode
```

You may toggle the counter input P3.6 with the VTREG PORT3, i.e. with a signal function:

```
signal void ToggleT3Input (void) {
    while (1) {
        PORT3 = PORT3 ^ 0x40; // toggle P3.6
        twatch (CLOCK / 100000); // with 100kHz
    }
}
```

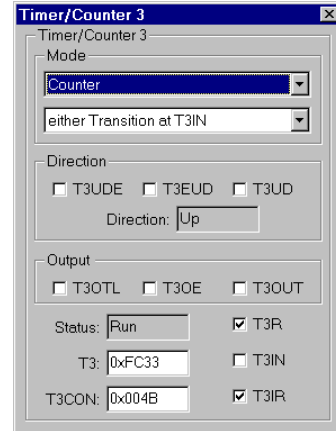

View the Counter 3 status with the Peripheral dialog.

Also interrupt inputs are simulated: if a port pin is used as interrupt input, the interrupt request will be set if you toggle the associated I/O pin.

5

Simulating External I/O Devices

External I/O devices are typical memory mapped. You may simulate such I/O devices with the **Memory Window** provided in the µVision2 debugger. Since the C user program does not contain any variable declarations for such memory regions it is required that you map this memory with the MAP command:

```
MAP X:0x1000, X:0x1FFF READ WRITE /* MAP memory for I/O area */
```

You may use breakpoints in combination with debug functions to simulate the logic behind the I/O device. Refer to “User Functions” on page 141 for more information. Example for a breakpoint definition:

```
BS WRITE 0x100000, 1, "IO_access ()"
```

Assigning Serial I/O to a PC COM Port

The ASSIGN command allows you to use a PC COM Port as input for an UART in the μ Vision2 simulator. If you enter the following commands, serial I/O is performed via the COM2: interface of your PC. The STIME variable allows you to ignore the timing of the simulated serial interface.

```
>MODE COM2 9600, 0, 8, 1 /*9600 bps, no parity, 8 data & 1 stop bit*/
>ASSIGN COM2 <S0IN >S0OUT /*ASC0 output & input is done with COM2:*/
>SOTIME = 0 /*ignore timing of simulated ASC0 interface*/
```

Checking Illegal Memory Accesses

Sometimes it is required to trap illegal memory accesses. The μ Vision2 access breakpoints might be used together with the system variable `_break_`. In the following example the program execution stops when the array `save_record` is accessed outside of the function `clear_records`.

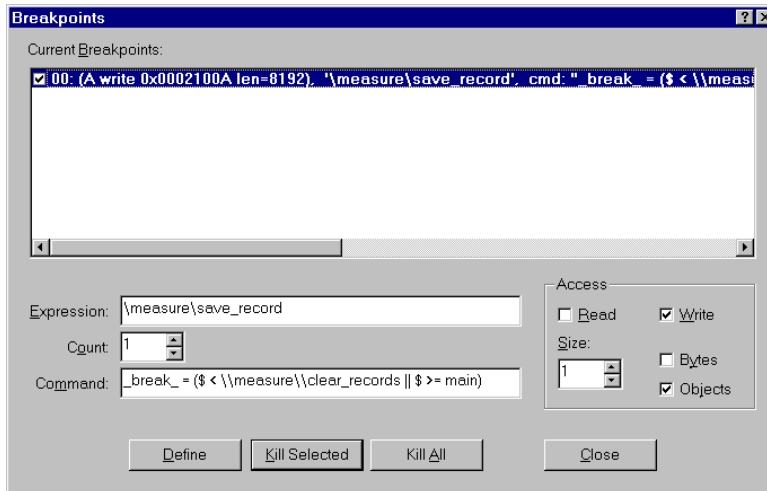

Command Input from File

Commands for the μ Vision2 debugger might be read from file with the INCLUDE command. Under **Options for Target - Debug** you may also specify an **Initialization File** with debug commands. Refer to page 102 for more information.

Presetting I/O Ports or Memory Contents

Some applications require that I/O port values or memory contents are set to specific values before program simulation. In the debug **Initialization File** you may include the commands that are required to preset the simulator. Example:

```
PORT3 = 0          /* set Port3 to zero          */
LOAD MEMORY.HEX   /* load hex file contents to memory          */
/* use the SAVE command to save memory contents */
```

Writing Debug Output to a File

The commands **LOG** and **SLOG** can be used to write debug output files. You may run the μ Vision2 debugger in batch files and use a debug **Initialization File** that contains these commands to automate program test. Refer to “ μ Vision 2 Command Line Invocation” on page 211 for additional information.

```
>LOG >>C:\TMP\DEBUGOUT.TXT /* protocol Output Window - Command page*/
>SLOG >>C:\TMP\DEBUGOUT.TXT /* protocol Serial Window output          */
>/* Output of the Command page and the Serial Window written to file */
>LOG OFF                /* stop Output Window protocol          */
>SLOG OFF                /* stop Serial Window protocol          */
```

Using Keyboard Shortcuts

View – Options allows you to configure shortcut keys for all menu items. With this dialog you may personalize μ Vision2 to your needs. For example, you may add a shortcut key to insert/remove breakpoints in an editor window.

NOTE

The assignment of shortcut keys is saved in the file C:\KEIL\UV2\UV2.MAC.

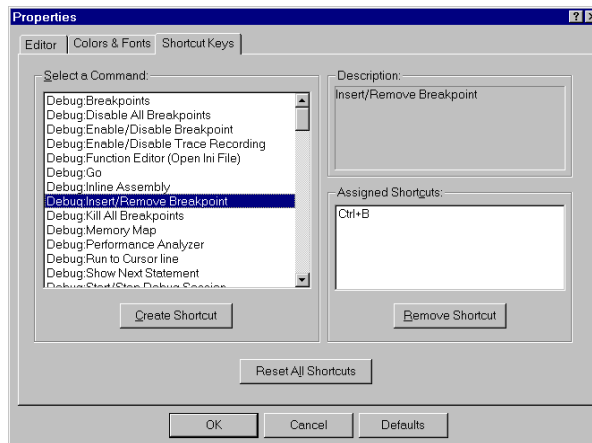

Kernel Aware Debugging

μ Vision2 supports Kernel Awareness for operating systems with debug DLLs. Refer to “RTX Kernel Aware Debugging” on page 180 for details on testing programs that use the RTX-51 Tiny real-time operating system. RTX-51 Full applications are tested with similar features. μ Vision2 allows you to add own debug DLLs that display the status information for operating systems or other applications. We will provide an **Application Note** on www.keil.com that explains how to write user-specific debug DLLs for the μ Vision2 debugger.

Chapter 6. μ Vision2 Debug Functions

This chapter discusses a powerful aspect of the μ Vision2: debug functions. You may use functions to extend the capabilities of the μ Vision2 debugger. You may create functions that generate external interrupts, log memory contents to a file, update analog input values periodically, and input serial data to the on-chip serial port.

NOTE

*Do not confuse μ Vision2 debug functions with functions of your target program. μ Vision2 debug functions aids you in debugging of your application and are entered or with the **Function Editor** or on μ Vision2 command level.*

μ Vision2 debug functions utilize a subset of the C programming language. The basic capabilities and restrictions are as follows:

- Flow control statements **if**, **else**, **while**, **do**, **switch**, **case**, **break**, **continue**, and **goto** may be used in debug functions. All of these statements operate in μ Vision2 debug functions as they do in ANSI C.
- Local scalar variables are declared in debug functions in the same way they are declared in ANSI C. Arrays are not allowed in debug functions.

For a complete description of the “Differences Between Debug Functions and C” refer to page 147.

Creating Functions

μ Vision2 has a built-in debug function editor which opens with **Debug – Function Editor**. When you start the function editor, the editor asks for a file name or opens the file specified under **Options for Target – Debug – Initialization File**. The debug function editor works in the same way as the build-in μ Vision2 editor and allows you to enter and compile debug functions.

```

Function Editor - measure.ini
Open New... Save Save As... Compile
Compile Errors:
/*-----*/
/* MyStatus shows analog and other values ... */
/*-----*/

FUNC void MyStatus (void) {
printf ("=====\n");
printf (" Analog-Input-0:  %f\n", ain0);
printf (" Analog-Input-1:  %f\n", ain1);
printf (" Analog-Input-2:  %f\n", ain2);
printf (" Analog-Input-3:  %f\n", ain3);
printf (" Registers (CP):  %04X\n", CP);
printf (" Program Counter: %06LXH\n", $);
printf ("=====\n");
}

```

Options	Description
Open	open an existing file with μ Vision2 debug functions or commands.
New	create a new file
Save	save the editor content to file.
Save As	specify a file for saving the debug functions.
Compile	send current editor content to the μ Vision2 command interpreter. This compiles all debug functions.
Compile Errors	shows a list of all errors. Choose an error, this locates the cursor to the erroneous line in the editor window.

6

Once you have created a file with μ Vision2 debug functions, you may use the **INCLUDE** command to read and process the contents of the text file. For example, if you type the following command in the command window, μ Vision2 reads and interprets the contents of **MYFUNCS.INI**.

```
>INCLUDE MYFUNCS.INI
```

MYFUNCS.INI may contain debug commands and function definitions. You may enter this file also under **Options for Target – Debug - Initialization File**. Every time you start the μ Vision2 debugger, the contents of **MYFUNCS.INI** will be processed.

Functions that are no longer needed may be deleted using the **KILL** command.

Invoking Functions

To invoke or run a debug function you must type the name of the function and any required parameters in the command window. For example, to run the **printf** built-in function to print “Hello World,” enter the following text in the command window:

```
>printf ("Hello World\n")
```

The μ Vision2 debugger responds by printing the text “Hello World” in the Command page of the Output Window.

Function Classes

μ Vision2 supports the following three classes of functions: Predefined Functions, User Functions, and Signal Functions.

- **Predefined Functions** perform useful tasks like waiting for a period of time or printing a message. Predefined functions cannot be removed or redefined.
- **User Functions** extend the capabilities of μ Vision2 and can process the same expressions allowed at the command level. You may use the predefined function **exec**, to execute debug commands from user and signal functions.
- **Signal Functions** simulate the behavior of a complex signal generator and lets you create various input signals to your target application. For example, signals can be applied on the input lines of the CPU under simulation. Signal functions run in the background during your target program’s execution. Signal functions are coupled via a CPU states counter that has a resolution of one instruction state. A maximum of 64 signal functions may be active simultaneously.

As functions are defined, they are entered into the internal table of user or signal functions. You may use the **DIR** command to list the predefined, user, and signal functions available.

DIR BFUNC displays the names of all built-in functions. **DIR UFUNC** displays the names of all user functions. **DIR SIGNAL** displays the names of all signal functions. **DIR FUNC** displays the names of all user, signal, and built-in functions.

Predefined Functions

μ Vision2 includes a number of predefined debug functions that are always available for use. They cannot be redefined or deleted. Predefined functions are provided to assist the user and signal functions you create.

The following table lists all predefined μ Vision2 debug functions.

Return	Name	Parameter	Description
void	<code>exec</code>	("command_string")	Execute Debug Command
double	<code>getdbl</code>	("prompt_string")	Ask the user for a double number
int	<code>getint</code>	("prompt_string")	Ask the user for a int number
long	<code>getlong</code>	("prompt_string")	Ask the user for a long number
void	<code>memset</code>	(start_addr, len, value)	fill memory with constant value
void	<code>printf</code>	("string", ...)	works like the ANSI C printf function
int	<code>rand</code>	(int seed)	return a random number in the range -32768 to +32767
void	<code>rwatch</code>	(address)	Delay execution of signal function until the specified memory address is read.
void	<code>wwatch</code>	(address)	Delay execution of signal function until the specified memory address is written.
void	<code>swatch</code>	(ulong states)	Delay execution of signal function for the specified number of seconds.
void	<code>twatch</code>	(float seconds)	Delay execution of signal function for the specified number of CPU states.
int	<code>_TaskRunning_</code>	(ulong func_address)	Checks if the specified task function is the current running task. Only available if a DLL for RTX Kernel Awareness is used.
uchar	<code>_RBYTE</code>	(address)	Read char on specified memory address
uint	<code>_RWORD</code>	(address)	Read int on specified memory address
ulong	<code>_RDWORD</code>	(address)	Read long on specified memory address
float	<code>_RFLOAT</code>	(address)	Read float on specified memory address
double	<code>_RDOUBLE</code>	(address)	Read double on specified memory address
void	<code>_WBYTE</code>	(address, uchar val)	Write char on specified memory address
void	<code>_WORD</code>	(address, uint val)	Write int on specified memory address
void	<code>_DWORD</code>	(address, ulong val)	Write long on specified memory address
void	<code>_WFLOAT</code>	(address, float val)	Write float on specified memory address
void	<code>_WDOUBLE</code>	(address, double val)	Write double on specified memory address

The predefined functions are described below.

void exec (“command_string”)

The `exec` function lets you invoke μ Vision2 debug commands from within your user and signal functions. The *command_string* may contain several commands separated by semicolons.

The *command_string* is passed to the command interpreter and must be a valid debug command.

Example

```
>exec ("DIR PUBLIC; EVAL R7")  
>exec ("BS timer0")  
>exec ("BK *")
```

double getdbl (“prompt_string”), int getint (“prompt_string”), long getlong (“prompt_string”)

This functions prompts you to enter a number and, upon entry, returns the value of the number entered. If no entry is made, the value 0 is returned.

Example

```
>age = getint ("Enter Your Age")
```

void memset (start address, ulong length, uchar value)

The `memset` function sets the memory specified with start address and length to the specified value.

Example

```
>MEMSET (0x20000, 0x1000, 'a') /* Fill 0x20000 to 0x20FFF with "a" */
```

void printf (“format_string”, ...)

The **printf** function works like the ANSI C library function. The first argument is a format string. Following arguments may be expressions or strings. The conventional ANSI C formatting specifications apply to **printf**.

Example

```
>printf ("random number = %04XH\n", rand(0))
random number = 1014H

>printf ("random number = %04XH\n", rand(0))
random number = 64D6H

>printf ("%s for %d\n", "uVision2", 8051)
uVision2 for 8051

>printf ("%lu\n", (ulong) -1)
4294967295
```

int rand (int seed)

The **rand** function returns a random number in the range -32768 to +32767. The random number generator is reinitialized each time a non-zero value is passed in the *seed* argument. You may use the **rand** function to delay for a random number of clock cycles or to generate random data to feed into a particular algorithm or input routine.

Example

```
>rand (0x1234)          /* Initialize random generator with 0x1234 */
0x3B98

>rand (0)              /* No initialization */
0x64BD
```

void twatch (long states)

The **twatch** function may be used in a signal function to delay continued execution for the specified number of CPU *states*. μ Vision2 updates the state counter while executing your target program.

Example

The following signal function toggles the INT0 input (P3.2) every second.

```
signal void int0_signal (void) {
  while (1) {
    PORT3 |= 0x04;      /* pull INT0 (P3.2) high */
    PORT3 &= ~0x04;    /* pull INT0 (P3.2) low and generate interrupt */
    PORT3 |= 0x04;      /* pull INT0 (P3.2) high again */
    twatch (CLOCK);    /* wait for 1 second */
  }
}
```

NOTE

The **twatch** function may be called only from within a signal function. Calls outside a signal function are not allowed and result in an error message.

void swatch (float seconds)

The **swatch** function may be used in a signal function to delay continued execution for the specified number of *seconds*.

Example

The following signal function toggles the INT0 input (P3.2) every half second.

```
signal void int0_signal (void) {
  while (1) {
    PORT3 |= 0x04;      /* pull INT0 (P3.2) high */
    PORT3 &= ~0x04;    /* pull INT0 (P3.2) low and generate interrupt */
    PORT3 |= 0x04;      /* pull INT0 (P3.2) high again */
    swatch (0.5);      /* wait for 1 second */
  }
}
```

NOTE

The **swatch** function may be called only from within a signal function. Calls outside a signal function are not allowed and result in an error message.

void rwatch (address)

The **rwatch** function may be used in a signal function to delay continued execution until the specified memory address is read from.

Example

The following signal function toggles Port 1.0 each time XDATA address 0x1234 is read.

```
signal void my_signal (void) {
    while (1) {
        PORT1 ^= 0x01;          /* toggle P1.0 */
        rwatch (X:0x1234);     /* wait until X:0x1234 is read */
    }
}
```

NOTE

*The **rwatch** function may be called only from within a signal function. Calls outside a signal function are not allowed and result in an error message.*

void wwatch (address)

The **wwatch** function may be used in a signal function to delay continued execution until the specified memory address is written to.

Example

The following signal function toggles Port 1.0 each time XDATA address 0x4000 is written.

```
signal void my_signal (void) {
    while (1) {
        PORT1 ^= 0x01;          /* toggle P1.0 */
        wwatch (X:0x4000);     /* wait until X:0x4000 is written */
    }
}
```

NOTE

*The **wwatch** function may be called only from within a signal function. Calls outside a signal function are not allowed and result in an error message.*

int `_TaskRunning_` (ulong *func_address*)

This function checks if the specified task function is the current running task. `_TaskRunning_` is only available if you select an **Operating System** under **Options for Target – Target**. μ Vision2 loads an additional DLL that kernel awareness for operating systems. Refer to “RTX Kernel Aware Debugging” on page 180 for more information.

The result of the debug function `_TaskRunning_` may be assigned to the `_break_` system variable to stop program execution when a specific task is active. An example is shown on page 182.

Example

```
> _TaskRunning_ (command)      /* check if task 'command' is running */
0001                          /* returns 1 if task is running      */
> _break = _TaskRunning_ (init) /* stop program when 'init' is running */
```

uchar `_RBYTE` (*address*),
uint `_RWORD` (*address*),
ulong `_RDWORD` (*address*),
float `_RFLOAT` (*address*),
double `_RDOUBLE` (*address*)

These functions return the content of the specified memory *address*.

Example

```
> _RBYTE (0x20000)             /* return the character at 0x20000 */
> _RFLOAT (0xE000)            /* return the float value at 0xE000 */
> _RDWORD (0x1000)           /* return the long value at 0x1000 */
```

`_WBYTE` (*address*, *uchar value*),
`_WWORD` (*address*, *uint value*),
`_WDWORD` (*address*, *ulong value*),
`_WFLOAT` (*address*, *float value*,
`_WDOUBLE` (*address*, *double value*)

These functions write a *value* to the specified memory *address*.

Example

```
> _WBYTE (0x20000, 0x55)      /* write the byte 0x33 at 0x20000 */  
> _RFLOAT (0xE000, 1.5)     /* write the float value 1.5 at 0xE000 */  
> _RDWORD (0x1000, 12345678) /* write the long value 12345678 at 0x1000*/
```

User Functions

User functions are functions you create to use with the μ Vision2 debugger. You may enter user functions directly in the function editor or you may use the **INCLUDE** command to load a file that contains one or more user functions.

NOTE

*μ Vision2 provides a number of system variables you may use in user functions. Refer to “**System Variables**” on page 113 for more information.*

User functions begin with **FUNC** keyword and are defined as follows:

```
FUNC return_type fname (parameter_list) {  
    statements  
}
```

return_type is the type of the value returned by the function and may be: **bit**, **char**, **float**, **int**, **long**, **uchar**, **uint**, **ulong**, **void**. You may use **void** if the function does not return a value. If no return type is specified the type **int** is assumed.

fname is the name of the function.

parameter_list is the list of arguments that are passed to the function. Each argument must have a type and a name. If no arguments are passed to the function, use **void** for the *parameter_list*. Multiple arguments are separated by commas.

statements are instructions the function carries out.

{ is the open curly brace. The function definition is complete when the number of open braces is balanced with the number of the closing braces (}).

Example

The following user function displays the contents of several CPU registers. For more information about “Creating Functions” refer to page 131.

```
FUNC void MyRegs (void) {
    printf ("----- MyRegs() -----\n");
    printf (" R4  R8  R9  R10 R11 R12\n");
    printf (" %04X %04X %04X %04X %04X %04X\n",
            R4, R8, R9, R10, R11, R12);
    printf ("-----\n");
}
```

To invoke this function, type the following in the command window.

```
MyRegs ()
```

When invoked, the **MyRegs** function displays the contents of the registers and appears similar to the following:

```
----- MyRegs () -----
R4  R8  R9  R10 R11 R12
B02C 8000 0001 0000 0000 0000
-----
```

You may define a toolbox button to invoke the user function with:

```
DEFINE BUTTON "My Registers", "MyRegs ()"
```

Restrictions

- μ Vision2 checks that the return value of a user function corresponds to the function return type. Functions with a **void** return type must not return a value. Functions with a non-**void** return type must return a value. Note that μ Vision2 does not check each return path for a valid return value.
- User functions may not invoke signal functions or the **twatch** function.
- The value of a local object is undefined until a value is assigned to it.
- Remove user functions using the **KILL FUNC** command.

Signal Functions

A Signal function let you repeat operations, like signal inputs and pulses, in the background while μ Vision2 executes your target program. Signal functions help you simulate and test serial I/O, analog I/O, port communications, and other repetitive *external* events.

Signal functions execute in the background while μ Vision2 simulates your target program. Therefore, a signal function must call the **twatch** function at some point to delay and let μ Vision2 run your target program. μ Vision2 reports an error for signal functions that never call **twatch**.

NOTE

μ Vision2 provides a number of system variables you may use in your signal functions. Refer to “System Variables” on page 113 for more information.

Signal functions begin with the **SIGNAL** keyword and are defined as follows:

```
SIGNAL void fname (parameter_list) {  
    statements  
}
```

fname is the name of the function.

parameter_list is the list of arguments that are passed to the function. Each argument must have a type and a name. If no arguments are passed to the function, use **void** for the *parameter_list*. Multiple arguments are separated by commas.

statements are instructions the function carries out.

{ is the open curly brace. The function definition is complete when the number of open braces is balanced with the number of the closing braces (“}”).

Example

The following example shows a signal function that puts the character ‘A’ into the serial input buffer once every 1,000,000 CPU states. For more information about “Creating Functions” refer to page 131.

```
SIGNAL void StuffS0in (void) {  
    while (1) {  
        S0IN = 'A';  
        twatch (1000000);  
    }  
}
```

To invoke this function, type the following in the command window.

```
StuffS0in()
```

When invoked, the **StuffS0in** signal function puts an ASCII character ‘A’ in the serial input buffer, delays for 1,000,000 CPU states, and repeats.

Restrictions

The following restrictions apply to signal functions:

- The return type of a signal function must be **void**.
- A signal function may have a maximum of eight function parameters.
- A signal function may invoke other predefined functions and user functions.
- A signal function may not invoke another signal function.
- A signal function may be invoked by a user function.
- A signal function must call the **twatch** function at least once. Signal functions that never call **twatch** do not allow the target program time to execute. Since you cannot use **Ctrl+C** to abort a signal function, μ Vision2 may enter an infinite loop.

Managing Signal Functions

μ Vision2 maintains a queue for active signal functions. A signal function may either be either idle or running. A signal function that is idle is delayed while it waits for the number of CPU states specified in a call to **twatch** to expire. A signal function that is running is executing statements inside the function.

When you invoke a signal function, μ Vision2 adds that function to the queue and marks it as running. Signal functions may only be activated once, if the function is already in the queue, a warning is displayed. View the state of active signal functions with the command **SIGNAL STATE**. Remove active signal functions from the queue with the command **SIGNAL KILL**.

When a signal function invokes the **twatch** function, it goes in the idle state for the number of CPU states passed to **twatch**. After the user program has executed the specified number of CPU states, the signal function becomes running. Execution continues at the statement after **twatch**.

If a signal function exits, because of a return statement, it is automatically removed from the queue of active signal functions.

Analog Example

The following example shows a signal function that varies the input to analog input 0 on a 8051 device with A/D converter. The function increases and decreases the input voltage by 0.5 volts from 0V and an upper limit that is specified as the signal function's only argument. This signal function repeats indefinitely, delaying 200,000 states for each voltage step.

```
signal void analog0 (float limit) {
    float volts;

    printf ("Analog0 (%f) entered.\n", limit);
    while (1) {
        /* forever */
        volts = 0;
        while (volts <= limit) {
            ain0 = volts;    /* analog input-0 */
            twatch (200000); /* 200000 states Time-Break */
            volts += 0.1;    /* increase voltage */
        }
        volts = limit;
        while (volts >= 0.0) {
            ain0 = volts;
            twatch (200000); /* 200000 states Time-Break */
            volts -= 0.1;    /* decrease voltage */
        }
    }
}
```

The signal function **analog0** can then be invoked as follows:

```
>ANALOG0 (5.0)                                     /* Start of 'ANALOG()' */
ANALOG0 (5.000000) ENTERED
```

The **SIGNAL STATE** command to displays the current state of the **analog0**:

```
>SIGNAL STATE
1 idle      Signal = ANALOG0 (line 8)
```

μ Vision2 lists the internal function number, the status of the signal function: idle or running, the function name and the line number that is executing.

Since the status of the signal function is idle, you can infer that **analog0** executed the **twatch** function (on line 8 of **analog0**) and is waiting for the specified number of CPU states to elapse. When 200,000 states pass, **analog0** continues execution until the next call to **twatch** in line 8 or line 14.

The following command removes the **analog0** signal function from the queue of active signal functions.

```
>SIGNAL KILL ANALOG0
```

Differences Between Debug Functions and C

There are a number of differences between ANSI C and the subset of features support in μ Vision2 debug user and signal functions.

- μ Vision2 does not differentiate between uppercase and lowercase. The names of objects and control statements may be written in either uppercase or lowercase.
- μ Vision2 has no preprocessor. Preprocessor directives like **#define**, **#include**, and **#ifdef** are not supported.
- μ Vision2 does not support global declarations. Scalar variables must be declared within a function definition. You may define symbols with the **DEFINE** command and use them like you would use a global variable.
- In μ Vision2, variables may not be initialized when they are declared. Explicit assignment statements must be used to initialize variables.
- μ Vision2 functions only support scalar variable types. Structures, arrays, and pointers are not allowed. This applies to the function return type as well as the function parameters.
- μ Vision2 functions may only return scalar variable types. Pointers and structures may not be returned.
- μ Vision2 functions cannot be called recursively. During function execution, μ Vision2 recognizes recursive calls and aborts function execution if one is detected.
- μ Vision2 functions may only be invoked directly using the function name. Indirect function calls via pointers are not supported.
- μ Vision2 supports only the ANSI style for function declarations with a parameter list. The old K&R format is not supported. For example, the following ANSI style function is acceptable.

```
func test (int pa1, int pa2) { /* ANSI type, correct */
/* ... */
}
```

The following K&R style function is not acceptable.

```
func test (pa1, pa2) /* Old K&R style is */
int pa1, pa2; /* not supported */
{
/* ... */
}
```

Differences Between dScope and the μ Vision2 Debugger

The μ Vision2 debugger replaces the Keil dScope for Windows. dScope debug functions require the following modifications for correct execution in the μ Vision2 debugger.

- In dScope the **memset** debug function parameters are different. The μ Vision2 **memset** debug function parameters are now identical with the ANSI C **memset** function.
- The dScope debug function **bit** is no longer available and needs to be replaced with **_RBYTE** and **_WBYTE** function calls. With dScope debug functions **char**, **uchar**, **int**, **uint**, **long**, **ulong**, **float**, and **double** it is possible to read and write memory. Replace these debug functions in μ Vision2 according the following list.

dScope Memory Access Function	μ Vision2 Debugger Replacement	
	Memory Read	Memory Write
bit	_RBYTE	combine _RBYTE and _WBYTE
char, uchar	_RBYTE	_WBYTE
int, uint	_RWORD	_WWORD
long, ulong	_RDWORD	_WDWORD
float	_RFLOAT	_WFLOAT
double	_RDOUBLE	_WDOUBLE

Chapter 7. Sample Programs

This section describes the sample programs that are included in our tool kits. The sample programs are ready for you to run. You can use the sample programs to learn how to use our tools. Additionally, you can copy the code from our samples for your own use.

The sample programs are found in the `C:\KEIL\C51\EXAMPLES\` folder. Each sample program is stored in a separate folder along with project files that help you quickly build and evaluate each sample program.

The following table lists the sample programs and their folder names.

Example	Description
BADCODE	Program with syntax errors and warnings. You may use the μ Vision2 editor to correct these.
BANK_EX1	A simple code banking application.
CSAMPLE	Simple addition and subtraction calculator that shows how to build a multi- module project with μ Vision2.
DHRY	Dhrystone benchmark. Calculates the dhrystones factor for the target CPU.
HELLO	Hello World program. Try this first when you begin using μ Vision2. It prints Hello World on the serial interface and helps you confirm that the development tools work correctly. Refer to "HELLO: Your First 8051 C Program" on page 150 for more information about this sample program.
MEASURE	Data acquisition system that collects analog and digital signals. Refer to "MEASURE: A Remote Measurement System" on page 155 for more information about this sample program.
RTX_EX1	Demonstrates round-robin multitasking using RTX-51 Tiny.
RTX_EX2	Demonstrates an RTX-51 Tiny application that uses signals.
SIEVE	Benchmark that calculates prime numbers.
TRAFFIC	Shows how to control a traffic light using the RTX-51 Tiny real-time executive.
WHETS	Benchmark program that calculates the whetstones factor for the target CPU.

To begin using one of the sample projects, use the μ Vision2 menu **Project – Open Project** and load the project file.

The following sections in this chapter describe how to use the tools to build the following sample programs:

- HELLO: Your First 8051 C Program
- MEASURE: A Remote Measurement System

HELLO: Your First 8051 C Program

The HELLO sample program is located in `C:\KEIL\C51\EXAMPLES\HELLO\`. HELLO does nothing more than print the text “Hello World” to the serial port. The entire program is contained in a single source file `HELLO.C`.

This small application helps you confirm that you can compile, link, and debug an application. You can perform these operations from the DOS command line, using batch files, or from μ Vision2 for Windows using the provided project file.

The hardware for HELLO is based on the standard 8051 CPU. The only on-chip peripheral used is the serial port. You do not actually need a target CPU because μ Vision2 lets you simulate the hardware required for this program.

HELLO Project File

In μ Vision, applications are maintained in a project file. A project file has been created for HELLO. To load this project, select **Open Project** from the **Project** menu and open `HELLO.UV2` from the folder `... \C51\EXAMPLES\HELLO`.

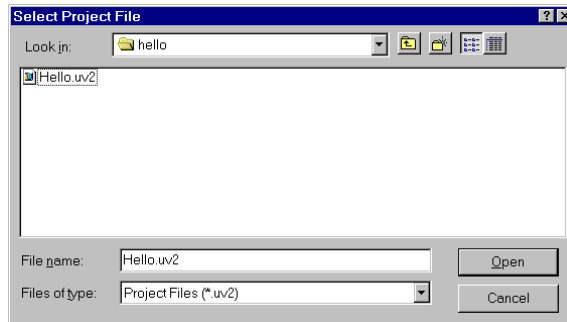

Editing HELLO.C

You can now edit `HELLO.C`. Double click on `HELLO.C` in the Files page of the Project Window. μ Vision2 loads and displays the contents of `HELLO.C` in an editor window.

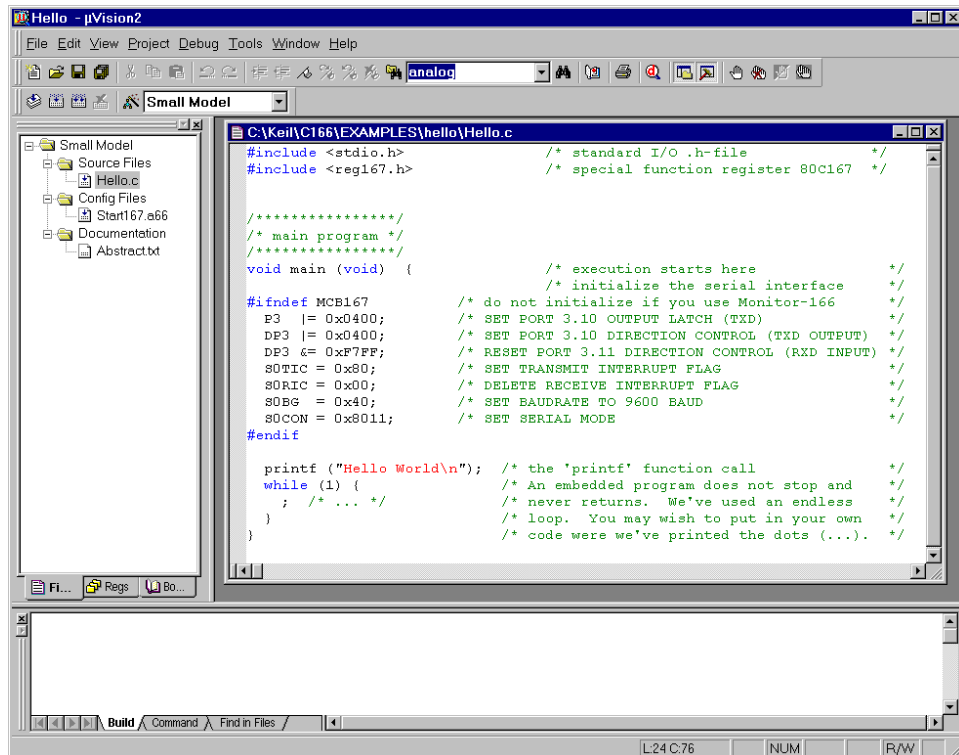

Compiling and Linking HELLO

When you are ready to compile and link your project, use the **Build Target** command from the **Project** menu or the Build toolbar. μ Vision2 begins to translate and link the source files and creates an absolute object module that you can load into the μ Vision2 debugger for testing. The status of the build process is listed in the **Build** page of the **Output Window**.



NOTE

You should encounter no errors when you use μ Vision2 with the provided sample projects.

Testing HELLO

Once the HELLO program is compiled and linked, you can test it with the μ Vision2 debugger. In μ Vision2, use the **Start/Stop Debug Session** command from the **Debug** menu or toolbar. μ Vision2 initializes the debugger and starts program execution till the main function. The following screen displays.

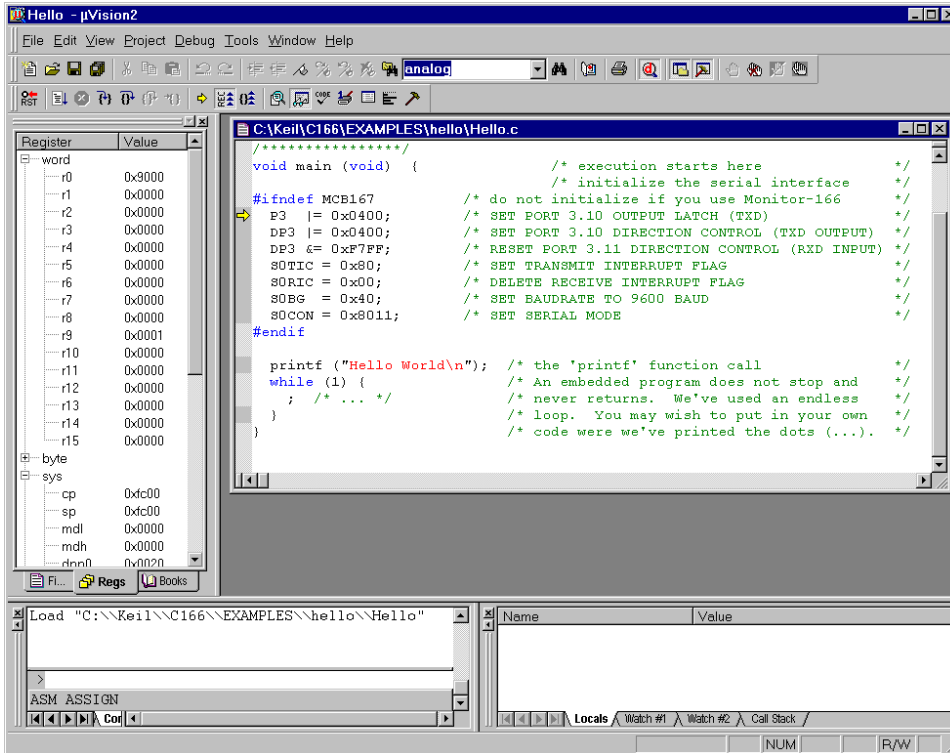

Open **Serial Window #1** that displays the serial output of the application with the **Serial Window #1** command from the **View** menu or the **Debug** toolbar.



Run HELLO with the **Go** command from the **Debug** menu or toolbar. The HELLO program executes and displays the text “Hello World” in the serial window. After HELLO outputs “Hello World,” it begins executing an endless loop.



Stop Running HELLO with the **Halt** command from the **Debug** menu or the toolbar. You may also type **ESC** in the Command page of the Output window.

During debugging μ Vision2 will show the following output:

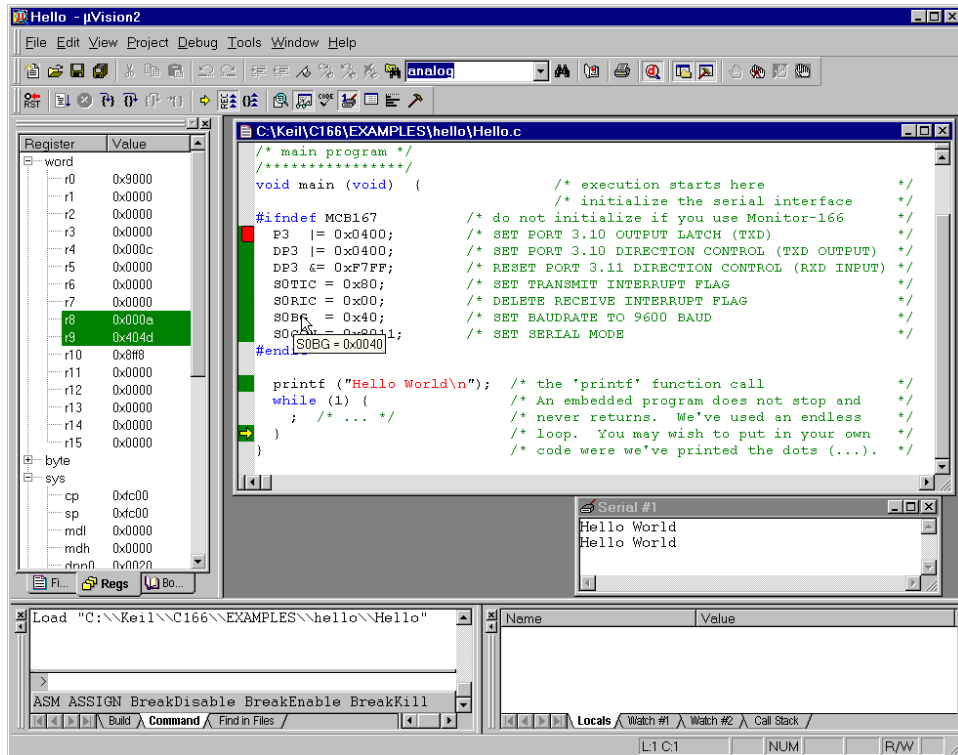

Single-Stepping and Breakpoints



Use the **Insert/Remove Breakpoints** command from the toolbar or the local editor menu that opens with a right mouse click and set a breakpoint at the beginning of the main function.



Use the **Reset CPU** command from the Debug menu or toolbar. If you have halted HELLO start program execution with **Run**, μ Vision2 will stop the program at the breakpoint.



You can single-step through the HELLO program using the Step buttons in the debug toolbar. The current instruction is marked with a yellow arrow. The arrow moves each time you step



Place the mouse cursor over a variable to view their value.



You may stop debugging at any time with **Start/Stop Debug Session** command.

command.

MEASURE: A Remote Measurement System

The MEASURE sample program is located in the `\C51\EXAMPLES\MEASURE\` folder. MEASURE runs a remote measurement system that collects analog and digital data like a data acquisition systems found in a weather stations and process control applications. MEASURE is composed of three source files: `GETLINE.C`, `MCOMMAND.C`, and `MEASURE.C`.

This implementation records data from two digital ports and four A/D inputs. A timer controls the sample rate. The sample interval can be configured from 1 millisecond to 60 minutes. Each measurement saves the current time and all of the input channels to a RAM buffer.

Hardware Requirements

The hardware for MEASURE is based on the C515 CPU. This microcontroller provides analog and digital input capability. Port 4 and port 5 is used for the digital inputs and AN0 through AN3 are used for the analog inputs. You do not actually need a target CPU because μ Vision2 lets you simulate all the hardware required for this program.

MEASURE Project File

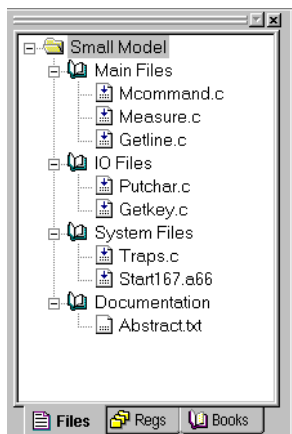

The project file for the MEASURE sample program is called `MEASURE.UV2`. To load this project file, use **Open Project** from the **Project** menu and select `MEASURE.UV2` in the folder `C:\KEIL\C51\EXAMPLES\MEASURE`.

The Files page in the Project Window shows the source files that compose the MEASURE project. The three application related source files that are located in the **Main Files** group. The function of the source files is described below. To open a source file, double-click on the filename.

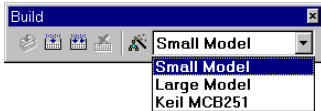

The project contains several targets for different test environments. For debugging with the simulator select the target Small Model in the Build toolbar.

- MEASURE.C** contains the main C function for the measurement system and the interrupt routine for timer 0. The main function initializes all peripherals of the C515 and performs command processing for the system. The timer interrupt routine, timer0, manages the real-time clock and the measurement sampling of the system.
- MCOMMAND.C** processes the display, time, and interval commands. These functions are called from main. The display command lists the analog values in floating-point format to give a voltage between 0.00V and 5.00V.
- GETLINE.C** contains the command-line editor for characters received from the serial port.



Compiling and Linking MEASURE

When you are ready to compile and link MEASURE, use the **Build Target** command from the Project menu or the toolbar. μ Vision2 begins to compile and link the source files in MEASURE and displays a message when the build is finished.

Once the project is build, you are ready to browse the symbol information or begin testing the MEASURE program.

Browse Symbols

The MEASURE project is configured to generate full browse and debug information. To view the information, use the **Source Browse** command from the View menu or the toolbar. For more information refer to “Source Browser” on page 69.

Testing MEASURE

The MEASURE sample program is designed to accept commands from the on-chip serial port. If you have actual target hardware, you can use a terminal simulation to communicate with the C515 CPU. If you do not have target hardware, you can use μ Vision2 to simulate the hardware. You can also use the serial window in μ Vision2 to provide serial input.

Once the MEASURE program is build, you can test it. Use the **Start/Stop Debug Session** command from the **Debug** menu to start the μ Vision2 debugger.

Remote Measurement System Commands

The serial commands that MEASURE supports are listed in the following table. These commands are composed of ASCII text characters. All commands must be terminated with a carriage return. You can enter these commands in the **Serial Window #1** during debugging.

Command	Serial Text	Description
Clear	C	Clears the measurement record buffer.
Display	D	Displays the current time and input values.
Time	T <i>hh:mm:ss</i>	Sets the current time in 24-hour format.
Interval	I <i>mm:ss.ttt</i>	Sets the interval time for the measurement samples. The interval time must be between 0:00.001 (for 1ms) and 60:00.000 (for 60 minutes).
Start	S	Starts the measurement recording. After receiving the start command, MEASURE samples all data inputs at the specified interval.
Read	R [<i>count</i>]	Displays the recorded measurements. You may specify the number of most recent samples to display with the read command. If no count is specified, the read command transmits all recorded measurements. You can read measurements on the fly if the interval time is more than 1 second. Otherwise, the recording must be stopped.
Quit	Q	Quits the measurement recording.



View Program Code

μ Vision2 lets you view the program code in the Disassembly Window that opens with the View menu or the toolbar button. The Disassembly Window shows intermixed source and assembly lines. You may change the view mode or use other commands from the local menu that opens with the right mouse button.

```

165: static char near cmdbuf [15];          /* c
166: unsigned char i;                      /* i
167: unsigned int idx;                     /* i
168:
169: #ifndef MCB167                          /* no init of serial interf
170: /* initialize the serial interface */
171: P3 |= 0x0400;                          /* SET PORT 3.10 OUTPUT LAT
000233DA 76E20004 OR P3,#0x0400
172: DP3 |= 0x0400;                          /* SET PORT 3.10 DIRECTION
000233DE 76E30004 OR
173: DP3 &= 0xF7FF;
000233E2 66E3FFF7 AND
174: SOTIC = 0x80;
000233E6 E6B68000 MOV
175: SORIC = 0x00;
000233EA E6B70000 MOV
176: SUBG = 0x40;
000233EE E65A4000 MOV
177: SOCON = 0x8011;
178: #endif
180: /* setup the timer
000233F2 E6D81180 MOV
181: TOREL = PERIOD;
000233F6 E62A3CF6 MOV
182: TO
  
```



View Memory Contents

μ Vision2 displays memory in various formats. The Memory Window opens via the View menu or the toolbar button. You can enter the address of four different memory areas in the pages. The local menu allows you to modify the memory contents or select different output formats.

```

Address: save_record
0002100A: FF 00 00 00 00 00 00 00 00 00 00 00
00021016: 00 00 00 00 FF 00 00 00 00 00 00 00
00021022: 00 01
0002102E: 00 01
0002103A: 00 01
00021046: 00 01
00021052: 00 01
0002105E: 00 01
0002106A: 00 01
00021076: 00 01
00021082: 00 01
0002108E: 00 00 00 00 00 00 00 00 00 00 00 00
0002109A: 00 00 00 00 00 00 00 00 00 00 00 00
000210A6: 00 00 00 00 00 00 00 00 00 00 00 00
  
```

Program Execution



Before you begin simulating MEASURE, open the **Serial Window #1** that displays the serial output with the **View** menu or the **Debug** toolbar. You

may disable other windows if your screen is not large enough.

You can use the Step toolbar buttons on assembler instructions or source code lines. If the Disassembly Window is active, you single step at assembly instruction basis. If an editor window with source code is active, you single step at source code level.



The **StepInto** toolbar button lets you single-step through your application and into function calls.



StepOver executes a function call as single entity and is not interrupt unless a breakpoint occurs.



On occasion, you may accidentally step into a function unnecessarily. You can use **StepOut** to complete execution of that function and return to the statement immediately following the function call.



A yellow arrow marks the current assembly or high-level statement. You may use the you may accidentally step into a function unnecessarily. You can use **StepOut** to complete execution of that function and return to the statement immediately following the function call.



The toolbar or local menu command **Run till Cursor Line** lets you use the current cursor line as temporary breakpoint.



With **Insert/Remove Breakpoints** command you can set or remove breakpoints on high-level source lines or assembler statements.



Call Stack

µVision2 internally tracks function nesting as the program executes. The **Call Stack** page of the **Watch Window** shows the current function nesting. A double click on a line displays the source code that called the selected function.

Callee	Caller
000: \Measure\save_measurements	\Measure\timer0\75
001: 0x00000080	\Putchar\putchar\51
002: \Putchar\putchar	\PRINTF\SaveCh
003: \?C?PRNFMT\print_formatter	\?C?PRNFMT\print_formatter
004: \PRINTF\printf	\Measure\main\191
005: \Measure\main	0x00000000

Trace Recording

It is common during debugging to reach a breakpoint where you require information like register values and other circumstances that led to the breakpoint. If **Enable/Disable Trace Recording** is set you can view the CPU instructions that were executed by reaching the breakpoint. The **Regs** page of the **Project Window** shows the CPU register contents for the selected instruction.

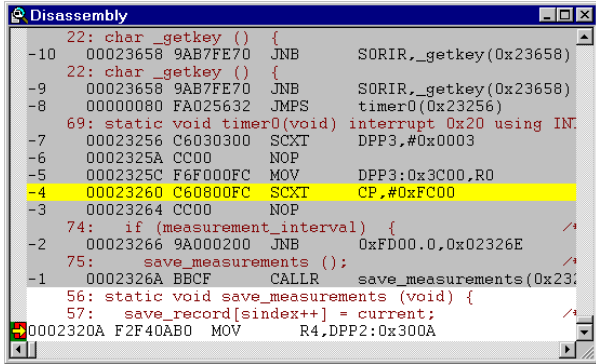

```

Disassembly
-10 00023658 9AB7FE70 JNB     SORIR,_getkey(0x23658)
22: char_getkey () {
-9 00023658 9AB7FE70 JNB     SORIR,_getkey(0x23658)
timer0(0x23256)
-8 00000080 FA025632 JMPS   timer0(0x23256)
69: static void timer0(void) interrupt 0x20 using INT
-7 00023256 C6030300 SCXT   DPP3,#0x0003
-6 0002325A CC00   NOP
-5 0002325C F6F000FC MOV   DPP3:0x3C00,R0
-4 00023260 C60800FC SCXT   CP,#0xFC00
-3 00023264 CC00   NOP
74: if (measurement_interval) {
-2 00023266 9A000200 JNB     0xFD00.0,0x02326E
75: save_measurements ();
-1 0002326A BBCE   CALLR save_measurements(0x23
56: static void save_measurements (void) {
57: save_record[sindex++] = current;
0002320A F2F40AB0 MOV   R4,DPP2:0x300A

```

Breakpoints Dialog

μ Vision2 also supports complex breakpoints as discussed on page 96. You may want to halt program execution when a variable contains a certain value. The example shows how to stop when the value 3 is written to **current.time.sec**.

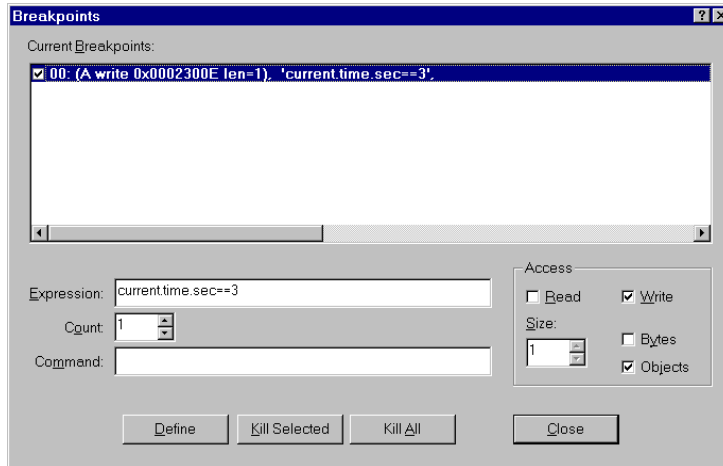

Open the **Breakpoints** dialog from the **Debug** menu. Enter as expression **current.time.sec==3**. Select the Write check box (this option specifies that the break condition is tested only when the expression is written to). Click on the Define button to set the breakpoint.

To test the breakpoint condition perform the following steps:



Reset CPU.



If program execution is halted begin executing the MEASURE program.

After a few seconds, μ Vision2 halts execution. The program counter line in the debug window marks the line in which the breakpoint occurred.

Watch Variables

You may constantly view the contents of variables, structures, and arrays. Open the **Watch Window** from the View menu or with the toolbar. The **Locals** page shows all local symbols of the current function. The Watch #1 and Watch #2 pages allow you to enter any program variables as described in the following:

- Select the text **<enter here>** with a mouse click and wait a second. Another mouse click enters edit mode that allows you to add variables. In the same way you can modify variable values.
- Select a variable name in an **Editor Window** and open the local menu with a right mouse click and use the command **Add to Watch Window**.
- You can enter **WatchSet** in the **Output Window – Command** page.

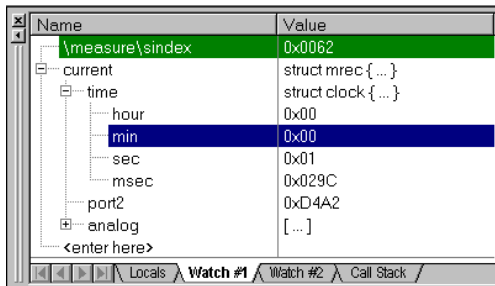

Name	Value
ymeasure\index	0x0062
current	struct mrec {...}
time	struct clock {...}
hour	0x00
min	0x00
sec	0x01
msec	0x029C
port2	0xD4A2
analog	[...]
<enter here>	[...]

To remove a variable, click on the line and press the **Delete** key.

Structures and arrays open on demand when you click on the [+] symbol. Display lines are indented to reflect the nesting level.

The Watch Window updates at the end of each execution command. You may enable **Periodic Window Update** in the View menu to update the watch window during program execution.

Viewing and Modifying On-Chip Peripherals

μ Vision2 provides several ways to view and modify the on-chip peripherals used in your target program. You may directly view the results of the example below when you perform the following steps:



Reset CPU and kill all defined breakpoints.



If program execution is halted begin executing the MEASURE program.



Open the **Serial Window #1** and enter the 'd' command for the MEASURE application. MEASURE shows the values from I/O Port2 and A/D input 0 – 3. The Serial Window shows the following output:

A screenshot of a serial window titled 'Serial #1'. The window has a purple title bar and standard window controls. The text inside the window reads: 'Command: d', 'Display current Measurements: (ESC to abort)', and 'Time: 0:01:45.323 P4:D1 P5:1F AN0:2.70V AN1:1.39V AN2:4.18V AN3:3.18V'. There are scroll bars on the right side of the text area.

```
Serial #1
Command: d
Display current Measurements: (ESC to abort)
Time: 0:01:45.323 P4:D1 P5:1F AN0:2.70V AN1:1.39V AN2:4.18V AN3:3.18V
```

You may now use the following procedures to supply input to the I/O pins.

Using Peripheral Dialog Boxes

µVision2 provides dialogs for: I/O Ports, Interrupts, Timers, A/D Converter, Serial Ports, and chip-specific peripherals. These dialogs can be opened from the Debug menu. For the MEASURE application you may open I/O Ports:Port4 and A/D Converter. The dialogs show the current status of the peripherals and you may directly change the input values.

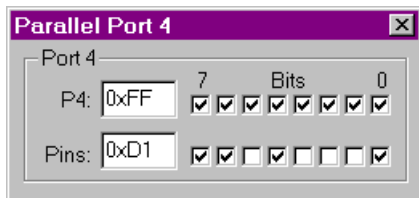

Each of these dialogs lists the related SFR symbols and shows the current status of the peripherals. To change the inputs, change the values of the Pins or Analog Input Channels.

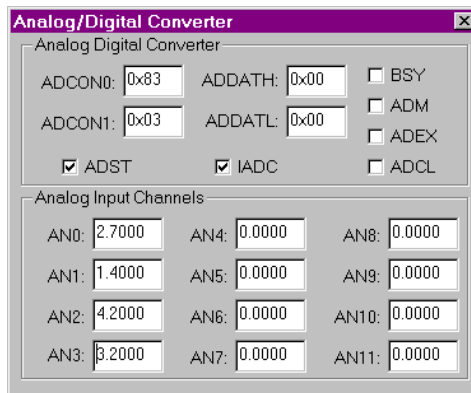

Using VTREG Symbols

You may use the “CPU Pin Registers (VTREGs)” described on page 114 to change input signals. In the **Command** page of the **Output Window**, you may make assignments to the VTREG symbols just like variables and registers. For example:

```
PORT4=0xDA          set digital input PORT4 to 0xDA.
AIN1=3.3            set analog input AIN1 to 3.3 volts.
```

Using User and Signal Functions

You may combine the use of VTREG symbols defined by the CPU driver and μ Vision2 user and signal functions to create a sophisticated method of providing external input to your target programs. The “Analog Example” on page 146 shows a signal function that provides input to AIN0. The signal function is included in the MEASURE example and may be quickly invoked with the Toolbox button **Analog0..5V** and changes constantly the voltage on the input AIN0.

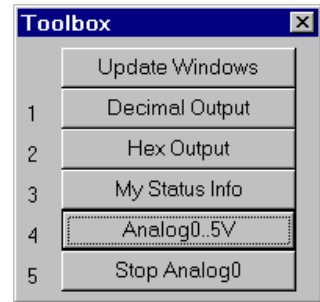



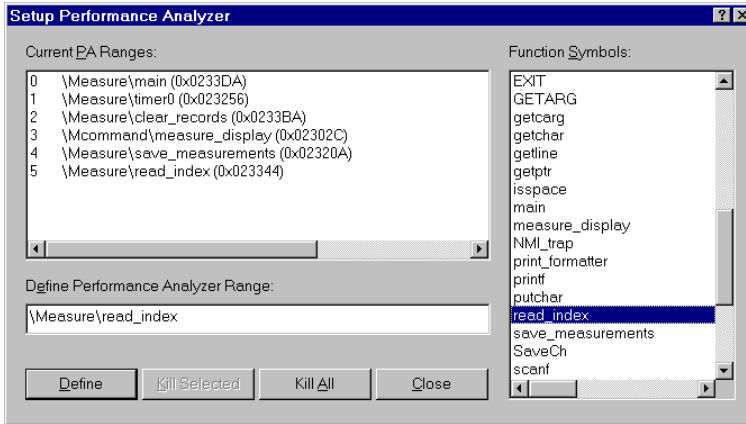

Using the Performance Analyzer

μVision2 lets you perform timing analysis of your applications using the integrated performance analyzer. To prepare for timing analysis, halt program execution and open the Setup **Performance Analyzer** dialog with the **Debug** menu.



You may specify the function names dialog box available from the Setup menu.

Perform the following steps to see the performance analyzer in action:

-  Open the Performance Analyzer using the **View** menu or toolbar.
-  Reset CPU and kill all breakpoints.
-  If program execution is halted begin executing the MEASURE program.
-  Select the **Serial Window #1** and type the commands **S Enter D Enter**

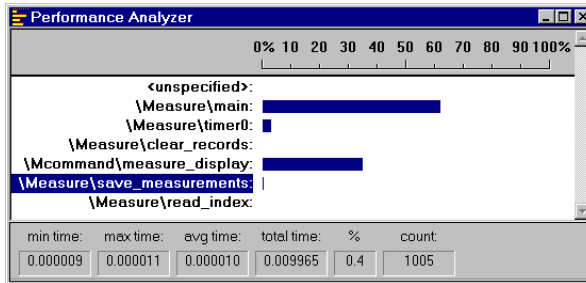

The Performance Analyzer shows a bar graph for each range. The bar graph shows the percent of the time spent executing code in each range. Click on the range to see detailed timing statistics. Refer to page 103 for more information.

The MEASURE application may be also tested on a Keil MCB517 board or other C515 or C517 starter kits. Refer to “Debugging with Monitor-51” on page 209.

Chapter 8. RTX-51 Real-Time Operating System

RTX51 is a multitasking real-time operating system for the 8051 family. RTX51 simplifies system and software design of complex and time-critical projects. RTX51 is a powerful tool to manage several jobs (tasks) on a single CPU. There are two distinct versions of **RTX51**:

RTX51 Full which performs both round-robin and preemptive task switching with 4 task priorities and can be operated with interrupt functions in parallel. RTX51 supports signal passing; message passing with a mailbox system and semaphores. The `os_wait` function of RTX51 can wait for the following events: interrupt; timeout; signal from task or interrupt; message from task or interrupt; semaphore.

RTX51 Tiny which is a subset of RTX51 Full. RTX51 Tiny easily runs on single-chip systems without off-chip memory. However, program using RTX51 Tiny can access off-chip memory. RTX51 Tiny allows round-robin task switching, supports signal passing and can be operated with interrupt functions in parallel. The `os_wait` function of RTX51 Tiny can wait for the following events: timeout; interval; signal from task or interrupt.

The rest of this section uses RTX-51 to refer to RTX-51 Full and RTX-51 Tiny. Differences between the two are stated where applicable.

Introduction

Many microcontroller applications require simultaneous execution of multiple jobs or tasks. For such applications, a real-time operating system (RTOS) allows flexible scheduling of system resources (CPU, memory, etc.) to several tasks. RTX-51 implements a powerful RTOS that is easy to use. RTX-51 works with all 8051 derivatives.

You write and compile RTX-51 programs using standard C constructs and compiling them with C51. Only a few deviations from standard C are required in order to specify the task ID and priority. RTX-51 programs also require that you include the `RTX51.H` or `RTX51TNY.H` header file. When you select in the μ Vision2 dialog Options for Target - Target the operating system, the linker adds the appropriate RTX-51 library file.

Single Task Program

A standard C program starts execution with the main function. In an embedded application, main is usually coded as an endless loop and can be thought of as a single task that is executed continuously. For example:

```
int counter;

void main (void) {
    counter = 0;

    while (1) {
        counter++;
    }
}
```

/* repeat forever */
/* increment counter */

Round-Robin Task Switching

RTX51 Tiny allows a quasi-parallel, simultaneous execution of several tasks. Each task is executed for a predefined timeout period. A timeout suspends the execution of a task and causes another task to be started. The following example uses this round-robin task switching technique.

Simple C Program using RTX51

```
#include <rtx51tiny.h> /* Definitions for RTX51 Tiny */
int counter0;
int counter1;

job0 () _task_ 0 {

    os_create_task (1); /* Mark task 1 as "ready" */

    while (1) {
        counter0++; /* Endless loop */
    } /* Increment counter 0 */
}

job1 () _task_ 1 {
    while (1) {
        counter1++; /* Endless loop */
    } /* Increment counter 1 */
}
```

8

RTX51 starts the program with task 0 (assigned to job0). The function `os_create_task` marks task 1 (assigned to job1) as ready for execution. These two functions are simple count loops. After the timeout period has been completed, RTX51 interrupts job0 and begins execution of job1. This function even reaches the timeout and the system continues with job0.

The os_wait Function

The `os_wait` function provides a more efficient way to allocate the available processor time to several tasks. `os_wait` interrupts the execution of the current task and waits for the specified event. During the time in which a task waits for an event, other tasks can be executed.

Wait for Timeout

RTX51 uses an 8051 timer in order to generate cyclic interrupts (timer ticks). The simplest event argument for `os_wait` is a timeout, where the currently executing task is interrupted for the specified number of timer ticks. The following uses timeouts for the time delay.

Program with os_wait Function

```
#include <rtx51tiny.h>          /* Definitions for RTX51 Tiny */

int counter0;
int counter1;

job0 () _task_ 0 {

    os_create_task (1);

    while (1) {
        counter0++;           /* Increment counter 0          */
        os_wait (K_TMO, 3, 0); /* Wait 3 timer ticks      */
    }
}

job1 () _task_ 1 {
    while (1) {
        counter1++;           /* Increment counter 1          */
        os_wait (K_TMO, 5, 0); /* Wait 5 timer ticks          */
    }
}
```

This program is similar to the previous example with the exception that `job0` is interrupted with `os_wait` after `counter0` has been incremented. RTX51 waits three timer ticks until `job0` is ready for execution again. During this time, `job1` is executed. This function also calls `os_wait` with a timeout of 5 ticks. The result: `counter0` is incremented every three ticks and `counter1` is incremented every five timer ticks.

Wait for Signal

Another event for `os_wait` is a signal. Signals are used for task coordination: if a task waits with `os_wait` until another task issues a signal. If a signal was previously sent, the task is immediately continued.

Program with Wait for Signal.

```
#include <rtx51tiny.h>          /* Definitions for RTX51 Tiny */

int counter0;
int counter1;

job0 () _task_ 0 {

    os_create_task (1);

    while (1) {
        if (++counter0 == 0) {    /* On counter 0 overflow      */
            os_send_signal (1);  /* Send signal to task 1  */
        }
    }
}

job1 () _task_ 1 {
    while (1) {
        os_wait (K_SIG, 0, 0);   /* Wait for signal; no timeout */
        counter1++;              /* Increment counter 1        */
    }
}
```

In this example, task 1 waits for a signal from task 0 and therefore processes the overflow from counter0.

Preemptive Task Switching

The full version of RTX51 provides preemptive task switching. This feature is not included in RTX51 Tiny. It is explained here to provide a complete overview of multitasking concepts.

In the previous example, task 1 is not immediately started after a signal has arrived, but only after a timeout occurs for task 0. If task 1 is defined with a higher priority than task 0, by means of preemptive task switching, task 1 is started immediately after the signal has arrived. The priority is specified in the task definition (priority 0 is the default value).

RTX51 Technical Data

Description	RTX-51 Full	RTX-51 Tiny
Number of tasks	256; max. 19 tasks active	16
RAM requirements	40 .. 46 bytes DATA 20 .. 200 bytes IDATA (user stack) min. 650 bytes XDATA	7 bytes DATA 3 * <task count> IDATA
Code requirements	6KB .. 8KB	900 bytes
Hardware requirements	timer 0 or timer 1	timer 0
System clock	1000 .. 40000 cycles	1000 .. 65535 cycles
Interrupt latency	< 50 cycles	< 20 cycles
Context switch time	70 .. 100 cycles (fast task) 180 .. 700 cycles (standard task) depends on stack load	100 .. 700 cycles depends on stack load
Mailbox system	8 mailboxes with 8 integer entries each	not available
Memory pool system	up to 16 memory pools	not available
Semaphores	8 * 1 bit	not available

Overview of RTX51 Routines

The following table lists some of the RTX-51 functions along with a brief description and execution timing (for RTX-51 Full).

Function	Description	CPU Cycles
isr_recv_message †	Receive a message (call from interrupt).	71 (with message)
isr_send_message †	Send a message (call from interrupt).	53
isr_send_signal	Send a signal to a task (call from interrupt).	46
os_attach_interrupt †	Assign task to interrupt source.	119
os_clear_signal	Delete a previously sent signal.	57
os_create_task	Move a task to execution queue.	302
os_create_pool †	Define a memory pool.	644 (size 20 * 10 bytes)
os_delete_task	Remove a task from execution queue.	172
os_detach_interrupt †	Remove interrupt assignment.	96
os_disable_isr †	Disable 8051 hardware interrupts.	81
os_enable_isr †	Enable 8051 hardware interrupts.	80
os_free_block †	Return a block to a memory pool.	160
os_get_block †	Get a block from a memory pool.	148
os_send_message †	Send a message (call from task).	443 with task switch
os_send_signal	Send a signal to a task (call from tasks).	408 with task switch 316 with fast task switch 71 without task switch
os_send_token †	Set a semaphore (call from task).	343 with fast task switch 94 without task switch
os_set_slice †	Set the RTX-51 system clock time slice.	67
os_wait	Wait for an event.	68 for pending signal 160 for pending message

† These functions are available only in RTX-51 Full.

Additional debug and support functions in RTX-51 Full include the following:

Function	Description
oi_reset_int_mask	Disables interrupt sources external to RTX-51.
oi_set_int_mask	Enables interrupt sources external to RTX-51.
os_check_mailbox	Returns information about the state of a specific mailbox.
os_check_mailboxes	Returns information about the state of all mailboxes in the system.
os_check_pool	Returns information about the blocks in a memory pool.
os_check_semaphore	Returns information about the state of a specific semaphore.
os_check_semaphores	Returns information about the state of all semaphores in the system.
os_check_task	Returns information about a specific task.

Function	Description
<code>os_check_tasks</code>	Returns information about all tasks in the system.

CAN Functions

The CAN functions are available only with RTX-51 Full. CAN controllers supported include the Philips 82C200 and 80C592 and the Intel 82526. More CAN controllers are in preparation.

CAN Function	Description
<code>can_bind_obj</code>	Bind an object to a task; task is started when object is received.
<code>can_def_obj</code>	Define communication objects.
<code>can_get_status</code>	Get CAN controller status.
<code>can_hw_init</code>	Initialize CAN controller hardware.
<code>can_read</code>	Directly read an object's data.
<code>can_receive</code>	Receive all unbound objects.
<code>can_request</code>	Send a remote frame for the specified object.
<code>can_send</code>	Send an object over the CAN bus.
<code>can_start</code>	Start CAN communications.
<code>can_stop</code>	Stop CAN communications.
<code>can_task_create</code>	Create the CAN communication task.
<code>can_unbind_obj</code>	Disconnect the binding between a task and an object.
<code>can_wait</code>	Wait for reception of a bound object.
<code>can_write</code>	Write new data to an object without sending it.

TRAFFIC: RTX-51 Tiny Example Program

The TRAFFIC example is a pedestrian traffic light controller that shows the usage of multitasking RTX-51 Tiny Real-time operating system. During a user-defined time interval, the traffic light is operating. Outside this time interval, the yellow light flashes. If a pedestrian pushes the request button, the traffic light goes immediately into *walk* state. Otherwise, the traffic light works continuously.

Traffic Light Controller Commands

The serial commands that TRAFFIC supports are listed in the following table. These commands are composed of ASCII text characters. All commands must be terminated with a carriage return.

Command	Serial Text	Description
Display	D	Display clock, start, and ending times.
Time	T <i>hh:mm:ss</i>	Set the current time in 24-hour format.
Start	S <i>hh:mm:ss</i>	Set the starting time in 24-hour format. The traffic light controller operates normally between the start and end times. Outside these times, the yellow light flashes.
End	E <i>hh:mm:ss</i>	Set the ending time in 24-hour format.

Software

The TRAFFIC application is composed of three files that can be found in the `\KEIL\C51\EXAMPLES\TRAFFIC` folder.

`TRAFFIC.C` contains the traffic light controller program that is divided into the following tasks:

- **Task 0 init:** initializes the serial interface and starts all other tasks. Task 0 deletes itself since initialization is needed only once.
- **Task 1 command:** is the command processor for the traffic light controller. This task controls and processes serial commands received.
- **Task 2 clock:** controls the time clock.
- **Task 3 blinking:** flashes the yellow light when the clock time is outside the active time range.
- **Task 4 lights:** controls the traffic light phases while the clock time is in the active time range (between the start and end times).
- **Task 5 keyread:** reads the pedestrian push button and sends a signal to the task lights.
- **Task 6 get_escape:** If an ESC character is encountered in the serial stream the command task gets a signal to terminate the display command.

`SERIAL.C` implements an interrupt driven serial interface. This file contains the functions *putchar* and *getkey*. The high-level I/O functions *printf* and *getline* call these basic I/O routines. The traffic light application will also operate without using interrupt driven serial I/O. but will not perform as well.

`GETLINE.C` is the command line editor for characters received from the serial port. This source file is also used by the MEASURE application.

TRAFFIC Project



Open the TRAFFIC.UV2 project file that is located in \KEIL\C51\EXAMPLES\TRAFFIC folder with μ Vision2. The source files for the TRAFFIC project will be shown in the **Project Window – Files** page.

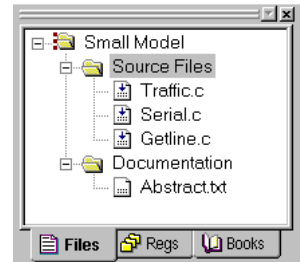

The RTX-51 Tiny Real-Time OS is selected under Options for Target.

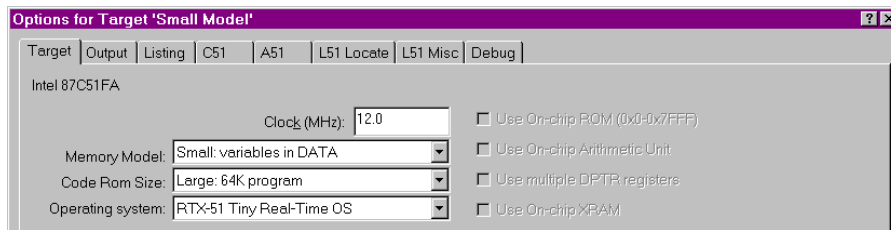

Build the TRAFFIC program with **Project - Build** or the toolbar button.



Run the TRAFFIC Program

You can test TRAFFIC with the μ Vision2 simulator.



The watch variables shown on the right allow you to view port status that drives the lights.

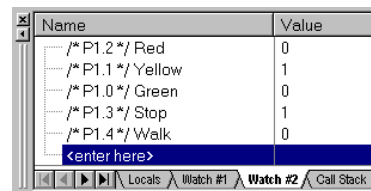

The **push_key** signal function simulates the pedestrian push key that switches the light system to *walk* state. This function is called with the **Push for**

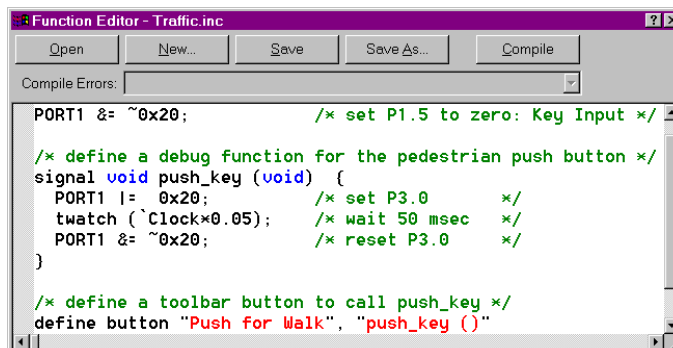

Use **Debug – Function Editor** to open TRAFFIC.INC. This file is specified

the **Push for Walk** toolbar button.

under **Options for Target – Debug – Initialization File** and defines the signal function **push_key**, the port initialization and the toolbar button.

Note: the VTREG symbol *Clock* is literalized with a back quote (`), since there is a C function named *clock* in the **TRAFFIC.C** module. Refer to “Literal Symbols” on page 121 for more information.



Now run the **TRAFFIC** application. Enable **View – Periodic Window Update** to view the lights in the watch window during program execution.



The **Serial Window #1** displays the *printf* output and allows you to enter the traffic light controller commands described in the table above.

Set the clock time outside of the start/end time interval to flash the yellow light.

```

Serial #1
| with pedestrian self-service. Outside of this time range
| the yellow caution lamp is blinking.
+-----+-----+-----+
| command  +- syntax  +-----+ function
| Display  | D          |         | display times
| Time     | T hh:mm:ss |         | set clock time
| Start    | S hh:mm:ss |         | set start time
| End      | E hh:mm:ss |         | set end time
+-----+-----+-----+

Command: d
Start Time: 07:30:00      End Time: 18:30:00
Clock Time: 12:02:44

```

RTX Kernel Aware Debugging

A RTX application can be tested with the same methods and commands as standard 8051 applications. When you select an **Operating System** under **Options for Target – Target**, μ Vision2 enables additional debugging features: a dialog lists the operating system status and with the `_TaskRunning_` debug function you may stop program execution when a specific task is active.

The following section exemplifies RTX debugging with the TRAFFIC example.



Stop program execution, reset the CPU and kill all breakpoints.



An RTX-51 application can be tested in the same way as standard applications. You may open source files, set break points and single step through the code. The TRAFFIC application starts with task 0 *init*.



```

C:\Keil\C51\EXAMPLES\TRAFFIC\TRAFFIC.C
/*****
/*      Task 0 'init': Initialize
*****/
void init (void) _task_INIT {          /* program execution start
serial_init ();                       /* initialize the serial i
os_create_task (CLOCK);               /* start clock task
os_create_task (COMMAND);            /* start command task
os_create_task (LIGHTS);             /* start lights task
os_create_task (KEYREAD);            /* start keyread task
os_delete_task (INIT);               /* stop init task (no long
}
  
```



μ Vision2 is completely kernel aware. You may display the task status with the menu command **Peripherals – RTX Tiny Tasklist**.

TID	Task Name	State	Wait for Event	Sig	Timer	Stack
0	init	Deleted		0	0x31	0x7F
1	command	Running		0	0x31	0x7F
2	clock	Waiting	Timeout	0	0x25	0xF7
3	blinking	Deleted		0	0x31	0xF9
4	lights	Waiting	Signal & TimeOut	0	0x34	0xF9
5	keyread	Waiting	Timeout	0	0x01	0xFB
6	get_escape	Ready		0	0x31	0xFD

The dialog **RTX51 Tiny Tasklist** gives you the following information:

Heading	Description
TID	<i>task_id</i> used in the definition of the task function.
Task Name	name of the task function.
State	task state of the function; explained in detail in the next table.
Wait for Event	event the task is waiting for; the following events are possible (also in combination): Timeout: the task Timer is set to the duration is specified with the <i>os_wait</i> function call. After the Timer decrements to zero, the task goes into Ready state. Interval: the time interval specified with <i>os_wait</i> is added to the task Timer value. After the Timer decrements to zero, the task goes into Ready state. Signal: the <i>os_wait</i> function was called with K_SIG and the task waits for Sig = 1 .
Sig	status of the Signal bit that is assigned to this task.
Timer	value of the Timer that is assigned to this task. The Timer value decrements with every RTX system timer tick. If the Timer becomes zero and the task is waiting for Timeout or Interval the task goes into Ready state.
Stack	value of the stack pointer (SP) that is used when this task is Running .

RTX-51 Tiny contains an efficient stack management that is explained in the "RTX51 Tiny" User's Guide, Chapter 5: RTX51 Tiny, Stack Management.

This manual provides detailed information about the **Stack** value.

State	Task State of a RTX51 Task Function
Deleted	Tasks that are not started are in the Deleted state.
Ready	Tasks that are waiting for execution are in the Ready state. After the currently Running task has finished processing, RTX starts the next task that is in the Ready state.
Running	The task currently being executed is in the Running state. Only one task is in the Running state at a time.
Timeout	Tasks that were interrupted by a round-robin timeout are in the Timeout state. This state is equivalent to Ready ; however, a round-robin task switch is marked due to internal operating procedures.
Waiting	Tasks that are waiting for an event are in the Waiting state. If the event occurs which the task is waiting for, this task then enters the Ready state.

The **Debug – Breakpoints...** dialog allows you to define breakpoints that stop the program execution only when the task specified in the `_TaskRunning_` debug function argument is **Running**. Refer to “Predefined Functions” on page 134 for a detailed description of the `_TaskRunning_` debug function.

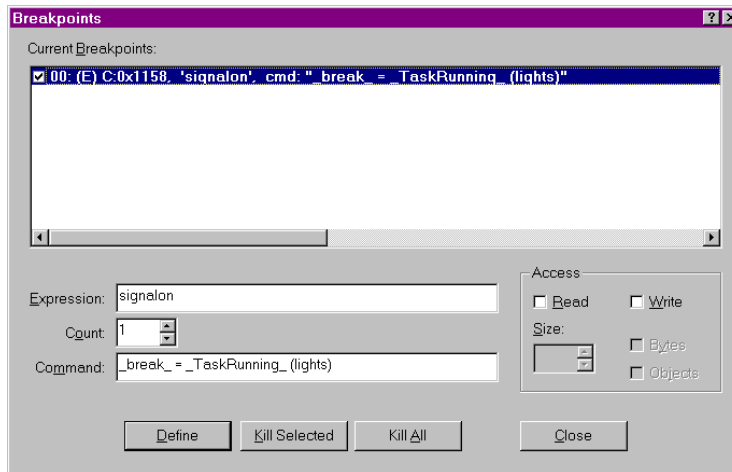

The breakpoint at the function *signalon* stops execution only if *lights* is the current **Running** task.

Chapter 9. Using On-chip Peripherals

9

There are a number of techniques you must know to create programs that utilize the various on-chip peripherals and features of the 8051 family. Many of these are described in this chapter. You may use the code examples provided here to quickly get started working with the 8051.

There is no single standard set of on-chip peripherals for the 8051 family. Instead, 8051 chip vendors use a wide variety of on-chip peripherals to distinguish their parts from each other. The code examples in this chapter demonstrate how to use the peripherals of a particular chip or family. Be aware that there are more configuration options than are presented in this text.

Topic	Page
Special Function Registers	183
Register Banks	184
Interrupt Service Routines	185
Parallel Port I/O	187
Timers/Counters	189
Serial Interface	190
Watchdog Timer	193
D/A Converter	194
A/D Converter	195
Power Reduction Modes	196

NOTE

The code examples presented here were tested using the μ Vision2 Debugger. Each of the examples may be downloaded from the Keil web site by selecting the appropriate chip from the on-line device database at www.keil.com/dd.

Special Function Registers

The on-chip peripherals of the 8051 are accessed using special function registers or SFRs. SFRs are located in on-chip directly addressable memory from 80h to 0FFh. The Keil development tools provide include files or header files that define these registers for you. You may include the provided header files or you may create and include your own header files to access the on-chip peripherals.

When you are creating projects with μ Vision2 you can insert the special function register definition of the device via the local menu in an editor window.

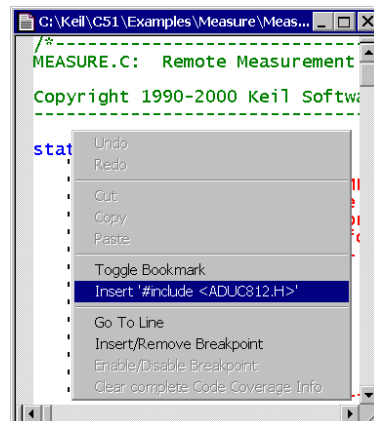

Use the local editor menu to insert correct register header files.

Many of the example programs presented in this chapter begin with a line of code that is similar to the following:

```
#include <reg51.h>
```

The register definition files are located in the folder C:\KEIL\C51\INC or in sub-folders. The following excerpt from such a register definition file shows the definitions for the parallel I/O ports.

```
sfr P0 = 0x80;    // 8-bit I/O Port P0
sfr P1 = 0x90;    // 8-bit I/O Port P1
sfr P2 = 0xA0;    // 8-bit I/O Port P2
sfr P3 = 0xB0;    // 8-bit I/O Port P3
```

You may define own SFR symbols directly in your C source or header files. The C51 compiler supports both: byte SFR and bit SFR symbols as shown in the following example:

```
sfr IE = 0xA8;    // Interrupt Enable register at SFR address 0xA8
sbit EA = IE^7;   // global Interrupt Enable Flag (bit 7 of SFR IE)
```

NOTES

Before you can read from or write to a Special Function Register, you must declare the SFR symbol in your source file.

Bit SFR symbols can be defined only for bit-addressable SFR registers that are located on sfr address 0x80, 0x88, 0x90, .. 0xF8.

Register Banks

The 8051 is an accumulator-based microcontroller with eight general-purpose registers (R0-R7). Each register is a single byte register. All eight general-purpose registers may be considered a bank of registers or a register bank.

The 8051 provides four register banks you can use. The primary reason for multiple register banks becomes apparent when you use interrupts.

For typical 8051 C programs there is no need to select or switch register banks. Register bank 0 is used by default.

Register bank 1, 2, or 3 are best used in interrupt service routines to avoid saving and restoring registers on the stack.

Interrupt Service Routines

The C51 compiler lets you write interrupt service routines in C. The compiler generates very efficient entry and exit code and accommodates register bank switching. Interrupt routines are declared as follows:

```
void function_name (void) interrupt interrupt_number [using register_bank]
```

The *interrupt_number* determines the interrupt vector address of the interrupt function. Use the following table to determine the interrupt number.

Interrupt Number	Address	Interrupt Number	Address
0 (EXTERNAL INT 0)	0003h	16	0083h
1 (TIMER/COUNTER 0)	000Bh	17	008Bh
2 (EXTERNAL INT 1)	0013h	18	0093h
3 (TIMER/COUNTER 1)	001Bh	19	009Bh
4 (SERIAL PORT)	0023h	20	00A3h
5 (TIMER/COUNTER 2)	002Bh	21	00ABh
6 (PCA)	0033h	22	00B3h
7	003Bh	23	00BBh
8	0043h	24	00C3h
9	004Bh	25	00CBh
10	0053h	26	00D3h
11	005Bh	27	00DBh
12	0063h	28	00E3h
13	006Bh	29	00EBh
14	0073h	30	00F3h
15	007Bh	31	00FBh

The **using** attribute lets you specify a *register_bank* that is selected during the execution of the interrupt function. Small interrupt routines might be more efficient without the **using** attribute, since they use the default register bank 0. You should compare the assembly code generated both with and without the **using** directive to see which is more efficient in your application.

NOTE

*Functions that are invoked from an interrupt procedure should be compiled with the **NOAREGS** directive. This ensures that the compiler does not generate absolute register accesses*

The following example program shows a typical interrupt function:

```
#include <reg51.h> // Special Function Registers of 80C51 CPU

#pragma NOAREGS    // do not use absolute register symbols (ARx)
                  // for functions called from interrupt routines.

static void HandleTransmitInterrupt (void) {
:
:
}

static void HandleReceiveInterrupt (void) {
:
:
}

#pragma AREGS     // for other code it is save to use ARx symbols

static void com_isr (void) interrupt 4 using 1 {
    if (TI) HandleTransmitInterrupt ();
    if (RI) HandleReceiveInterrupt ();
}

```

In the example above an interrupt service routine for interrupt number 4 is defined. The name of the interrupt function is `com_isr`. Once the interrupt is invoked, the entry code saves CPU registers and selects register bank 1. When the interrupt service routine exits, the CPU registers are restored.

The following listing shows the code generated by the C51 compiler for the above interrupt routine. Note that the register bank context is swapped on entry to the interrupt routine and is restored on exit.

```

; FUNCTION com_isr (BEGIN)
0000 C0E0      PUSH    ACC          ; Save the Accumulator and Data
Pointer
0002 C083      PUSH    DPH
0004 C082      PUSH    DPL
0006 C0D0      PUSH    PSW          ; Save PSW (and the current Register
Bank)
0008 75D008    MOV     PSW,#08H     ; This selects Register Bank 1
:
:
0052 D0D0      POP     PSW          ; Restore PSW (and prior reg bank)
0054 D082      POP     DPL
0056 D083      POP     DPH
0058 D0E0      POP     ACC          ; Restore the Accumulatorand DPTR
005A 32       RETI
; FUNCTION com_isr (END)

```

Interrupt Enable Registers

The 8051 provides interrupt services for many on-chip peripheral events. Interrupts are globally enabled and disabled using the **EA** bit of the Interrupt Enable (**IE**) SFR. When **EA** is set to 1, interrupts are enabled. When **EA** is set to 0, interrupts are disabled.

Each interrupt is individually controlled through bits in the **IE** SFR. On some 8051 derivatives there may be more than one **IE** register. Check the documentation for the chip you use to determine what interrupts are available.

NOTE

*In order for an interrupt service routine to execute when an interrupt occurs, the interrupt enable SFR for that interrupt must be set and the **EA** SFR must be set.*

In addition to the **IE** register, many 8051 derivatives allow you to assign a priority level to each interrupt using an Interrupt Priority (**IP**) SFR. Check the documentation for your microcontroller to determine how to use the interrupt priorities.

Parallel Port I/O

The standard 8051 provides four parallel I/O ports you may use for your target application. These are Port 0, Port 1, Port 2, and Port 3. Some derivatives of the 8051 have as many as eight I/O ports.

Port	Direction	Width	Alternate Use
P0	I/O	8 bits	Mux'd. 8-bit bus: A0-A7 & D0-D7
P1	I/O	8 bits	P1.0-P1.7: Available for User I/O
P2	I/O	8 bits	Mux'd. 8-bit bus: A8-A15
P3	I/O	8 bits	P3.0: RXD (Serial Port Receive) P3.1: TXD (Serial Port Transmit) P3.2: /INT0 (Interrupt 0 Input) P3.3: /INT1 (Interrupt 1 Input) P3.4: T0 (Timer/Counter 0 Input) P3.5: T1 (Timer/Counter 1 Input) P3.6: /WR (Write Data Control) P3.7: /RD (Read Data Control)

The ports on a standard 8051 do not have data direction registers. Instead, the pins of Port 1, Port 2, and Port 3 each have internal pull-ups that allow them to

9

be either inputs or outputs. To write to a port, you simply write the value you want to appear on the port pins. To read from a port, you must first write a 1 to the desired port bit (which is also the initial value after chip RESET).

The following example program shows how to read and write to I/O pins.

```
sfr P1 = 0x90;          // SFR definition for Port 1
sfr P3 = 0xB0;          // SFR definition for Port 3

sbit DIPswitch = P1^4;  // DIP switch input on Port 1 bit 4
sbit greenLED   = P1^5;  // green LED output on Port 1 bit 5

void main (void) {
    unsigned char inval;

    inval = 0;           // initial value for inval
    while (1) {
        if (DIPswitch == 1) { // check if input P1.4 is high
            inval = P1 & 0x0F; // read bit 0 .. 3 from P1
            greenLED = 0;      // set output P1.5 to low
        }
        else {             // if input P1.4 is low
            greenLED = 1;     // set output P1.5 to high
        }

        P3 = (P3 & 0xF0) | inval; // output inval to P3.0 .. P3.3
    }
}
```

Timers/Counters

9

The 80C52 has three timer/counter units (**Timer 0**, **Timer 1**, and **Timer 2**). Timer 0 and Timer 1 are very similar and offer the same functionality while Timer 2 offers enhanced capability. Each timer may operate independently in a number of different modes including timer mode, counter mode, and baud rate generator mode (for the serial port).

The following example program shows how to use Timer 1 to generate a 10 KHz timer tick interrupt for timing purposes when you run it on a standard 80C51 device with 12 MHz XTAL frequency. The timer tick interrupt increments the **overflow_count** variable once for each interrupt. The **main** C function initializes the timer loops forever inside the while (1) loop.

```
#include <reg52.h>

/*
 * Timer 1 Interrupt Service Routine:  executes every 100 clock cycles
 */

static unsigned long overflow_count = 0;

void timer1_ISR (void) interrupt 3 {
    overflow_count++;          // Increment the overflow count
}

/*
 * MAIN C function: sets Timer1 for 8-bit timer w/reload (mode 2).
 * The timer counts to 255, overflows, is reloaded with 156, and
 * generates an interrupt.
 */

void main (void) {
    TMOD = (TMOD & 0x0F) | 0x20;  // Set Mode (8-bit timer with reload)

    TH1 = 256 - 100;              // Reload TL1 to count 100 clocks
    TL1 = TH1;
    ET1 = 1;                      // Enable Timer 1 Interrupts
    TR1 = 1;                      // Start Timer 1 Running
    EA = 1;                      // Global Interrupt Enable

    while (1);                    // Do Nothing (endless-loop):  the timer 1 ISR will
                                // occur every 100 clocks.  Since the 80C51 CPU runs
                                // at 12 MHz, the interrupt happens 10 KHz.
}
```

9

Serial Interface

The 8051 includes a standard RS-232 compatible serial port you may use with your application programs. The 8051 uses port pins P3.1 and P3.0 for transmit and receive respectively. There are several SFRs that you must properly configure before the serial port will function.

The 8051 provides full interrupt control for the serial port transmit and receive operations. You may poll the serial port control registers to determine when a character has been received or when the next character may be sent or you may create interrupt routines to handle these operations.

The serial interface is configured with the SFR registers SBUF, SCON and PCON. In addition, you must also configure Timer 1 or Timer 2 as the baud rate generator.

The following example program shows how to perform interrupt-driven serial I/O using the 8051 serial port. Interrupt routines in this example handle transmit interrupts and receive interrupts using 8-byte circular buffers. Routines are provided to transmit (**putbuf** and **putchar**) and receive (**_getkey**) characters and to initialize the serial channel (**com_initialize**). This source code can be used as replacement for the library routines **putchar** and **_getkey**. This also allows the **printf**, **scanf** and other library functions to work with the interrupt-driven I/O routines in this example.

```
#include <reg51.h>
#include <stdio.h>

#define XTAL      11059200    // CPU Oscillator Frequency
#define baudrate  9600      // 9600 bps communication baudrate

#define OLEN  8              // size of serial transmission buffer
unsigned char ostart;       // transmission buffer start index
unsigned char oend;         // transmission buffer end index
char idata    outbuf[OLEN]; // storage for transmission buffer

#define ILEN  8              // size of serial receiving buffer
unsigned char istart;       // receiving buffer start index
unsigned char iend;        // receiving buffer end index
char idata    inbuf[ILEN]; // storage for receiving buffer

bit    sendfull;           // flag: marks transmit buffer full
bit    sendactive;        // flag: marks transmitter active

/*
 * Serial Interrupt Service Routine
 */
static void com_isr (void) interrupt 4 using 1 {
    char c;
```

```

/*----- Received data interrupt. -----*/
if (RI) {
    c = SBUF;                // read character
    RI = 0;                 // clear interrupt request flag
    if (istart + ILEN != iend) {
        inbuf[iend++ & (ILEN-1)] = c; // but character into buffer
    }
}

/*----- Transmitted data interrupt. -----*/
if (TI != 0) {
    TI = 0;                // clear interrupt request flag
    if (ostart != oend) {  // if characters in buffer and
        SBUF = outbuf[ostart++ & (OLEN-1)]; // transmit character
        sendfull = 0;      // clear 'sendfull' flag
    }
    else {                 // if all characters transmitted
        sendactive = 0;    // clear 'sendactive'
    }
}
}

/*
 * Function to initialize the serial port and the UART baudrate.
 */
void com_initialize (void) {
    istart = 0;            // empty transmit buffers
    iend = 0;
    ostart = 0;           // empty transmit buffers
    oend = 0;
    sendactive = 0;       // transmitter is not active
    sendfull = 0;        // clear 'sendfull' flag

    PCON |= 0x80;        // 0x80=SMOD: set serial baudrate doubler
    TMOD |= 0x20;        // put timer 1 into MODE 2
    TH1 = (unsigned char) (256 - (XTAL / (16L * 12L * baudrate)));
    TR1 = 1;             // start timer 1

    SCON = 0x50;         // serial port MODE 1, enable serial receiver
    ES = 1;              // enable serial interrupts
}

/*
 * putbuf: write a character to SBUF or transmission buffer
 */
void putbuf (char c) {
    if (!sendfull) {     // transmit only if buffer not full
        if (!sendactive) { // if transmitter not active:
            sendactive = 1; // transfer first character direct
            SBUF = c;       // to SBUF to start transmission
        }
        else {
            ES = 0;        // disable serial interrupts during buffer update
            outbuf[oend++ & (OLEN-1)] = c; // put char to transmission buffer
            if (((oend ^ ostart) & (OLEN-1)) == 0) {
                sendfull = 1;
            }
            // set flag if buffer is full
        }
        ES = 1;          // enable serial interrupts again
    }
}

```

```

    }
}

/*
 * Replacement routine for the standard library putchar routine.
 * The printf function uses putchar to output a character.
 */
char putchar (char c) {
    if (c == '\n') {                // expand new line character:
        while (sendfull);          // wait until there is space in buffer
        putchar (0x0D);           // send CR before LF for <new line>
    }
    while (sendfull);              // wait until there is space in buffer
    putchar (c);                   // place character into buffer
    return (c);
}

/*
 * Replacement routine for the standard library _getkey routine.
 * The getchar and gets functions uses _getkey to read a character.
 */
char _getkey (void) {
    char c;
    while (iend == istart) {
        ;                          // wait until there are characters
    }
    ES = 0;                        // disable serial interrupts during buffer update
    c = inbuf[istart++ & (ILEN-1)];
    ES = 1;                        // enable serial interrupts again
    return (c);
}

/*
 * Main C function that start the interrupt-driven serial I/O.
 */
void main (void) {
    EA = 1;                        /* enable global interrupts */

    com_initialize ();             /* initialize interrupt driven serial I/O */

    while (1) {
        char c;
        c = getchar ();
        printf ("\nYou typed the character %c.\n", c);
    }
}

```

Watchdog Timer

The 8051Fx family of microcontrollers include a Programmable Counter Array (PCA) with a watchdog timer. You can use the watchdog as a method of recovery from hardware or software failures. The watchdog timer counts up. If the timer count matches a value stored in the PCA module 4 SFRs, the watchdog resets the MCU.

Your application must periodically update the PCA 4 value to avoid a watchdog reset. If your program does not reset the watchdog timer frequently enough or if your program crashes, the watchdog timer overflows and resets the CPU.

The following example code shows how to initialize the watchdog timer and how to reset it.

```
#include <reg51f.h>
/* This function adjusts the watchdog timer compare value to the current
 * PCA timer value + 0xFF00. Note that you must write to CCAP4L first,
 * then write to CCAP4H. */
void watchdog_reset (void) {
    unsigned char newval;

    newval = CH + 0xFF;
    CCAP4L = 0;
    CCAP4H = newval;
}

void main (void) {
    unsigned int i;

    /* Configure PCA Module 4 as the watchdog and make
     * sure it doesn't time-out immediately. */
    watchdog_reset ();
    CCAPM4 = 0x48;

    /* Configure the PCA for watchdog timer. */
    CMOD = (CMOD & 0x01) | 0x40;

    /* Start the PCA Timer: From this point on, we must reset the watchdog
     * timer every 0xFF00 clock cycles. If we don't, the watchdog timer
     * will reset the MCU. */
    CR = 1;

    /* Do something for a while and make sure that we don't get reset by
     * the watchdog. */
    for (i = 0; i < 1000; i++) {
        watchdog_reset ();
    }

    /* Stop updating the watchdog and we should get reset. */
    while (1);
}
```

9

D/A Converter

A D/A converter takes a digital input and outputs an analog voltage on one of the pins of the microcontroller. The Philips 87LPC769 is one of the many devices that offers built-in D/A converters.

The Philips 87LPC769 provides a 2-channel, 8-bit D/A converter that is easy to program. The following example code shows how to initialize the D/A converter and output voltages using the D/A SFRs..

```

/*
 * This program generates sawtooth waveforms on the DAC
 * of the Philips 87LPC769.
 */
#include <REG769.H>

void main (void) {
    // Disable the A/D Converter (this is required for DAC0)
    ADCI = 0;
    // Clear A/D conversion complete flag
    ADCS = 0;
    // Clear A/D conversion start flag
    ENADC = 0;
    // Disable the A/D Converter

    // Set P1.6 and P1.7 to Input Only (Hi Z).
    P1M2 &= ~0xC0;
    P1M1 |= 0xC0;

    ENDAC0 = 1;
    // Enable the D/A Converters
    ENDAC1 = 1;

    while (1) {
        unsigned int i;
        // Create a sawtooth wave on DAC0 and the
        // opposite sawtooth wave on DAC1.
        for (i = 0; i < 0x100; i++) {
            DAC0 = i;
            DAC1 = 0xFF - i;
        }
    }
}

```

A/D Converter

9

The Analog Devices ADuC812 provides 8 channels of 12-bit analog to digital conversion. Voltages presented to the analog input pins are converted to digital values and may be read from the A/D data registers.

The on-chip A/D converter may be configured for a number of conversion modes. It can generate an interrupt when a conversion has completed. The following example code shows how to initialize the A/D converter to cyclically convert each analog input channel and how to read and output the conversion results.

```
#include <ADUC812.H>
#include <stdio.h>

void main (void) {
    unsigned char chan_2_convert;

    SCON = 0x50;          // Configure the serial port.
    TMOD |= 0x20;
    TH1 = 0xA0;
    TR1 = 1;
    TI = 1;

    // Configure A/D to sequentially convert each input channel.
    ADCCON1 = 0x7C;      // 0111 1100
    while (1) {
        unsigned int conv_val;
        unsigned char channel;

        // Start a conversion and wait for it to complete.
        chan_2_convert = (chan_2_convert + 1) % 8;
        ADCCON2 = (ADCCON2 & 0xF0) | chan_2_convert;
        SCONV = 1;
        while (ADCCON3 & 0x80);

        // Read A/D data and print it out.
        channel = ADCDATAH >> 4;
        conv_val = ADCDATAH | ((ADCDATAH & 0x0F) << 8);

        printf ("ADC Channel %bu = 0x%4.4X\r\n", channel, conv_val);
    }
}
```

9

Power Reduction Modes

The 8051Fx offers two different power saving modes you may invoke: **Idle Mode** and **Power Down Mode**.

Idle Mode halts the CPU but lets interrupts, timer, and serial port functions continue operating. When an interrupt condition occurs, **Idle Mode** is canceled. Power consumption can be greatly decreased in idle mode.

Power Down Mode halts both the CPU and peripherals. It is canceled by a hardware reset or an external interrupt condition.

To enter **Idle Mode**, your program must set the IDL bit in the **PCON** SFR. You may do this directly in C as demonstrated by the following program.

```
sfr PCON = 0x87;

void main (void) {
    while (1) {
        task_a ();
        task_b ();
        task_c ();

        PCON |= 0x01;      /* Enter IDLE Mode - Wait for enabled interrupt */
    }
}
```

To enter **Power Down Mode**, your application must set the PD bit in the **PCON** SFR as demonstrated in the following program.

```
sfr PCON = 0x87;

void main (void) {
    while (1) {
        task_a ();
        task_b ();
        task_c ();

        PCON |= 0x02;      /* Enter Power Down Mode */
    }
}
```

Chapter 10. CPU and C Startup Code

The `STARTUP.A51` file contains the startup code for a C51 target program. This source file is located in the `LIB` directory. Include a copy of this file in each 8051 project that needs custom startup code.

This code is executed immediately upon reset of the target system and optionally performs the following operations, in order:

- Clears internal data memory
- Clears external data memory
- Clears paged external data memory
- Initializes the small model reentrant stack and pointer
- Initializes the large model reentrant stack and pointer
- Initializes the compact model reentrant stack and pointer
- Initializes the 8051 hardware stack pointer
- Transfers control to the main C function

The `STARTUP.A51` file provides you with assembly constants that you may change to control the actions taken at startup. These are defined in the following table.

Constant Name	Description
<code>IDATALEN</code>	Indicates the number of bytes of idata that are to be initialized to 0. The default is 80h because most 8051 derivatives contain at least 128 bytes of internal data memory. Use a value of 100h for the 8052 and other derivatives that have 256 bytes of internal data memory.
<code>XDATASTART</code>	Specifies the xdata address to start initializing to 0.
<code>XDATALEN</code>	Indicates the number of bytes of xdata to be initialized to 0. The default is 0.
<code>PDATASTART</code>	Specifies the pdata address to start initializing to 0.
<code>PDATALEN</code>	Indicates the number of bytes of pdata to be initialized to 0. The default is 0.
<code>IBPSTACK</code>	Indicates whether or not the small model reentrant stack pointer (<code>?C_IBP</code>) should be initialized. A value of 1 causes this pointer to be initialized. A value of 0 prevents initialization of this pointer. The default is 0.

Constant Name	Description
IBPSTACKTOP	<p>Specifies the top start address of the small model reentrant stack area. The default is 0xFF in idata memory.</p> <p>C51 does not check to see if the stack area available satisfies the requirements of the applications. It is your responsibility to perform such a test.</p>
XBPSTACK	<p>Indicates whether or not the large model reentrant stack pointer (<code>?C_XBP</code>) should be initialized. A value of 1 causes this pointer to be initialized. A value of 0 prevents initialization of this pointer. The default is 0.</p>
XBPSTACKTOP	<p>Specifies the top start address of the large model reentrant stack area. The default is 0xFFFF in xdata memory.</p> <p>C51 does not check to see if the available stack area satisfies the requirements of the applications. It is your responsibility to perform such a test.</p>
PBPSTACK	<p>Indicates whether the compact model reentrant stack pointer (<code>?C_PBP</code>) should be initialized. A value of 1 causes this pointer to be initialized. A value of 0 prevents initialization of this pointer. The default is 0.</p>
PBPSTACKTOP	<p>Specifies the top start address of the compact model reentrant stack area. The default is 0xFF in pdata memory.</p> <p>C51 does not check to see if the available stack area satisfies the requirements of the applications. It is your responsibility to perform such a test.</p>
PPAGEENABLE	<p>Enables (a value of 1) or disables (a value of 0) the initialization of port 2 of the 8051 device. The default is 0. The addressing of port 2 allows the mapping of 256 byte variable memory in any arbitrary xdata page.</p>
PPAGE	<p>Specifies the value to write to Port 2 of the 8051 for pdata memory access. This value represents the xdata memory page to use for pdata. This is the upper 8 bits of the absolute address range to use for pdata.</p> <p>For example, if the pdata area begins at address 1000h (page 10h) in the xdata memory, PPAGEENABLE should be set to 1, and PPAGE should be set to 10h. The BL51 Linker/Locator must contain a value between 1000h and 10FFh in the PDATA control directive. For example:</p> <pre>BL51 <input modules> PDATA (1050H)</pre> <p>Neither BL51 nor C51 checks to see if the PDATA control directive and the PPAGE assembler constant are correctly specified. You must ensure that these parameters contain suitable values.</p>

Chapter 11. Using Monitor-51

The Keil Monitor-51 allows you to debug programs on your target hardware using the μ Vision2 Debugger. You connect the μ Vision2 Debugger to your 8051 target board using a serial cable.

To get started, you must properly configure and install Monitor-51 on your target hardware. Configuration and installation of the Monitor is explained in the file `\KEIL\C51\MON51\MON51.PDF`.

Caveats

There are only a few drawbacks to using Monitor-51.

- The Monitor requires that programs you debug are located in RAM space. This is required because breakpoints are set by replacing instructions in your program with an ACALL instruction. This operation, while completely transparent, may have side-effects that affect the operation of your target program. Refer to “Breakpoint Side Effects” on page 203 for more information.
- You will most likely have to relocate your startup code, program code segments, and interrupt vector table.
- You may enable or disable the HALT command on the toolbar in μ Vision2 Debugger. If you enable this feature, using **Stop Program Execution with Serial Interrupt** check box under **Options – Debug – Keil Monitor-51 Driver Settings**, the μ Vision2 Debugger and the monitor use the 8051 serial interrupt vector to signal that the target program should stop running.

Hardware and Software Requirements

The following requirements must be met for Monitor-51 to operate correctly.

- The CPU must be an 8051 or derivative.
- The monitor requires 5 Kbyte external code memory (EPROM) starting at address 0.
- 256 Bytes of external data memory (XDATA RAM) is required. 5 Kbytes of trace buffer is optional. You must have enough external data memory to hold the complete application (code and data). **All** external data memory areas must be *von Neumann* wired—access must be possible from XDATA and CODE space. A common way to do this is to connect the /PSEN and /RD CPU signals to the inputs of an AND gate and the output of the AND gate to the /RD pin of the RAM.
- The monitor uses a serial interface with a timer as the baudrate generator.
- Between 1 and 5 port pins are necessary if you use banked hardware (for 2-32 banks). For details on banking hardware, refer to the example hardware schematics in the *8051 Utilities User's Guide, Chapter 1 "Bank Switching Configuration"*. All memory banks must be *von Neumann* wired.
- The monitor uses an additional 6 bytes of stack space (IDATA) in the user program to be tested.

All other hardware components can be used by the application.

Serial Transmission Line

Monitor-51 requires the following signals from the RS232 or V.24 line: **TRANSMIT DATA**, **RECEIVE DATA**, and **SIGNAL GROUND**. In many cases, additional connections are necessary in the serial connectors to enable transmit and receive data.

PIN connections of various computer systems

25 Pin Connector

Signal Name	Pin	Description
RxD	3	Receive data
TxD	2	Transmit data
Gnd	7	Signal ground

9 Pin Connector

Signal Name	Pin	Description
RxD	2	Receive data
TxD	3	Transmit data
Gnd	5	Signal ground

In addition to the above, you may be required to connect pin 7 to pin 8 and pin 1 to pin 4 and pin 6.

µVision2 Monitor Driver

µVision2 interfaces to target systems when you select **Use: Keil Monitor-51 Driver** in the dialog **Options – Debug**.

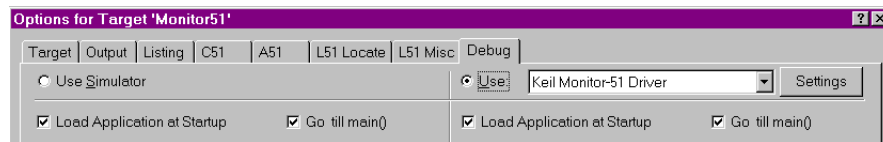

Click on **Settings** to open the dialog Monitor Driver Settings that allows you to configure various parameters such as COM port and baudrate. Refer to “Set Debug Options” on page 102 for more information about the Debug dialog.

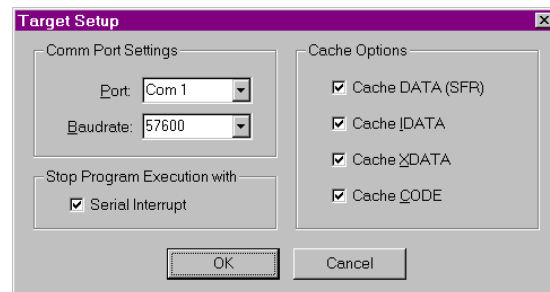

The following table describes the **Monitor Driver Settings** page:

Dialog Item	Description
Comm Port Settings	Select the PC COM port and the baudrate you want to use. If you have problems with your target hardware, try the Baudrate 9600. Sometimes not standard baudrates allow to use a different crystal frequency on a target board without having to reinstall Monitor-51. Example: A target board running at 12 MHz and 9600 bps can be modified to a 16MHz and 12800 bps by just exchanging the crystal.
Stop Program Execution with	When Serial interrupt is enabled, you can terminate a running application program with the Stop toolbar button or the ESC key in the Command page. To support this, the serial interface is not longer available for the user program. In addition, it is not allowed to reset the global Interrupt Enable (SFR Bit EA in IE.7) in your application.
Cache Options	To speed up the screen update, the Monitor driver implements several data caches. If you want to view the actual value of port pins, timers or memory mapped external peripherals you can switch off the cache for this memory area. To get the maximum performance you should enable all caches.

11

µVision2 Restrictions when using Monitor-51

The **memory mapping** of a CPU board with Monitor-51 is selected with hardware components. It is not possible to use **Debug – Memory Map** to change the memory mapping of the target system.

The **Performance Analyzer, Call Stack, Code Coverage** features, and the **Step Out** command are not available with Monitor-51. Also the option **View – Periodic Window Update** cannot be used with Monitor-51.

Breakpoint Options are handled directly by Monitor-51. However, when **access** or **conditional** breakpoints are set, the application is executed in single steps and not in real time. Single step execution is at least 1000 times slower.

Breakpoint Side Effects

When debugging programs it is sometimes necessary to stop the running of programs in order to check the system and eventually to correct any errors. To perform a breakpoint Monitor-51 writes a ACALL instruction in the user program. The advantage of this method is, that no additional hardware is required for the breakpoint logic. But with this method breakpoints can only be set in RAM memory. A second disadvantage is that a ACALL instruction occupies two bytes. Therefore, it can be dangerous, to set a breakpoint on a one-byte instruction, if a label (jump target) is after this instruction. The following example demonstrates this problem.

Test Program

```
8000 E4      CLR    A
8001 04      INC    A
.          .
.          .
.          .
8010 80 ED   SJMP   8001
```

First, the user program is executed until address 8010 with the following command.

```
>G 8000, 8010.
```

Afterwards, a breakpoint is set at address 8000. The breakpoint is realized by writing a ACALL instruction into the user program; this means that the user program is modified by the breakpoint.

Modified Test Program

```
8000 11      CLR    A      ; An ACALL instruction is
8002 XX      INC    A      ; written at address 8000.
.          .
.          .      ; Address 8001 is
.          .      ; occupied by the target of
.          .      ; the ACALL instruction.
8010 80 ED   SJMP   8001
```

If the interrupted program is continued at address 8010, the execution is not stopped at 8000. The reason is, that the user program jumps to address 8001 after the execution of the SJMP instruction. But at this address the second byte of the ACALL instruction resides in memory—not the INC instruction. Therefore the program execution at this point is unpredictable.

The user has to check that the ACALL instruction of a breakpoint overwrites no important OP codes. If needed, the user program should be executed by the **Trace** command. The Trace mode executes all instructions without conflicts.

Tool Configuration when Using Monitor-51

When you use Monitor-51, the complete target application is stored in *von Neumann* mapped RAM. This means that the code memory and xdata memory are accessing the same physical memory space. This is required, since the 8051 hardware is not able to write into code space and the Monitor changes the program code to set breakpoints in your application.

Therefore the **Eprom** and **RAM** areas that are entered in the dialog **Options – Target – Off-chip Memory** must be non-overlapping physical memory areas. These ranges are supplied to the Linker if you have enabled the option **Use Memory Layout from Target Dialog** in the **L51 Locate** dialog page. Therefore you should also check that this option is set.

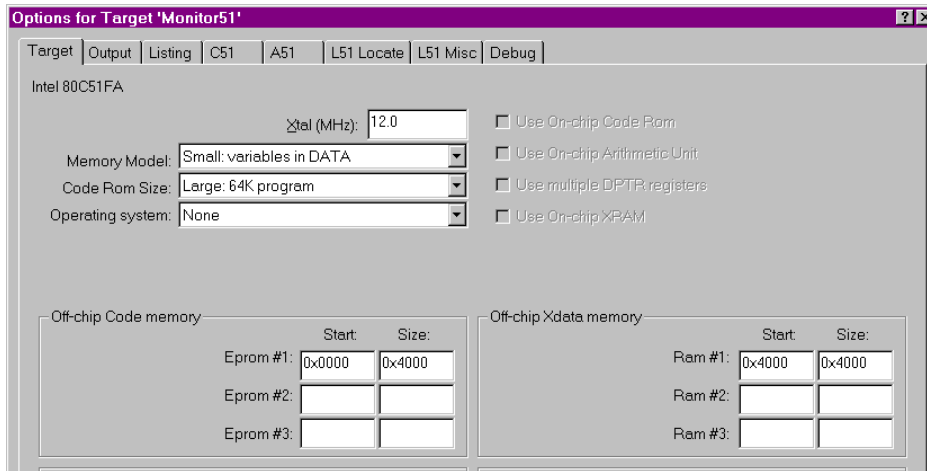

For debugging with **Monitor-51** the **code** and **xdata** space of the user application must be non-overlapping memory areas. Otherwise the user application overwrites the program code when xdata variables are accessed.

Using Stop Program Execution with Serial Interrupt

When you have enabled the option **Stop Program Execution with Serial Interrupt**, the Monitor-51 uses the serial interrupt of the UART. If you are using the standard 8051 UART, three bytes at the interrupt vector location C:0x0023 are modified by Monitor-51. You must ensure that the user program does not use these code locations. This can be done with the following C statements:

```
char code reserve [3] _at_ 0x23; /* for Monitor-51 serial interrupt */
```

When the Monitor-51 is Installed at Code Address 0

If you want to test a C program with Monitor-51 and if the Monitor-51 is installed at code address 0, consider the following rules (the specification refers to a target system where the available code memory for user programs starts at address 0x8000):

- All C modules which contain interrupt functions must be translated with the control directive INTVECTOR (0x8000). This option can be set under μ Vision2 in the dialog **Project Options - C51 - Interrupt vectors at address**.
- Copy the file \KEIL\C51\LIB\STARTUP.A51 into your project folder and add this file to your μ Vision2 project. In this copy of the STARTUP.A51 the statement CSEG AT 0 must be replaced with CSEG AT 8000H.

Monitor-51 Configuration

The Monitor-51 can be adapted to different hardware configurations using the INSTALL batch file in the folder \KEIL\C51\MON51. This utility is invoked from a DOS command prompt and has the following command line syntax:

```
INSTALL serialtype [xdatastart [codestart [BANK] [PROMCHECK]]]
```

The parameters of **INSTALL.BAT** are explained in the following.

serialtype defines the I/O routines used for the serial interface as explained in the table below.

Serial Type	Serial Interface	Clock Source	Baud Rate	CPU Clock	Processors
0	0	Timer 1	9600 bps	11,059 MHz	all 8051 variants
1	0	Int. Baudrate generator	9600 bps	12,000 MHz	80515(A), 80517(A)
2	0	Timer 2	9600 bps	12,000 MHz	8052 and compatibles
3	1	Int. Baudrate generator	9600 bps	12,000 MHz	80517(A)
4	0	Timer 2	9600 bps	12,000 MHz	Dallas 80C320 /520/530
5	1	Timer 2	9600 bps	12,000 MHz	Dallas 80C320 /520/530
6	ext. UART 16450/16550	Ext. Crystal 3,686400 MHz	9600 bps	don't care	All
7	0	Timer 1	Self adjusting	don't care	All
8	0	Timer 2	Self adjusting	don't care	8052 and compatibles
9	0	Int. Baudrate generator	Self adjusting	don't care	80515A, C505C C515C, 80517(A)
10	1	Int. Baudrate generator	Self adjusting	don't care	80517(A)
11	0	Timer2	Self adjusting	don't care	Dallas 80C320 /520/530
12	1	Timer 2	Self adjusting	don't care	Dallas 80C320 /520/530

xdatastart specifies the page number of the xdata memory area used by Monitor-51. The argument is a HEX value between **0** and **FF**. The default value is **FF**. Example: when *xdatastart* is **FF**, the memory area from X:0xFF00 to X:0xFFFF is used by Monitor-51 for internal variables and cannot be used by the user

application. This memory area needs to be von-Neumann RAM that can be accessed from code and xdata space.

codestart specifies the page number of the code memory area for the Monitor-51 program code. The Monitor code requires typically 4 ... 5 KBytes. The argument is a HEX value between 0 and **F0**. The default value is 0.

The option **BANK** creates a Monitor-51 version for a code banked target system. The file `MON_BANK.A51` defines the hardware configuration of the banking hardware. See section below for further information about hardware configurations with code banking.

If the Monitor is created with the option **PROMCHECK**, the Monitor-51 checks on CPU reset if an EPROM or a RAM is present at code address 0. If an EPROM is detected, a `JMP 0` instruction is executed that starts the code in the EPROM. **PROMCHECK** should be specified if the Monitor-51 code remains in the target system after the application has been programmed into an EPROM.

Example

```
INSTALL 8 7F 0
```

Creates a Monitor-51 version with self-adjusting baudrate that uses Timer 2 as the baudrate generator. The xdata space for internal Monitor-51 variables is between `X:0x7F00 .. X:0x7FFF`. The Monitor-51 code starts at address `C:0x0000`. This batch file creates the file `MON51.HEX` that can be burn into an EPROM.

NOTE

The file `\KEIL\C51\MON51\MON51.PDF` contains detailed information about the Monitor-51 configuration files and hardware requirements.

Troubleshooting

If the Monitor-51 does not start correctly it is typically a problem of Monitor code and data locations or the initialization of the serial interface.

If the Monitor-51 stops working or behaves strange during debugging of your application, your application is most likely overwriting the user application program. This might happen when the user application makes xdata write accesses to the program code locations. Code and xdata memory must be non-overlapping areas, since the Monitor-51 requires *von Neumann* wired code space, which means that code and xdata space are physically the same memory area. You should therefore check the XDATA and CODE MEMORY MAPPING that is listed in the Linker MAP (*.M51) file and verify that code and xdata space are not overlapping.

If the Monitor-51 does not single step CPU instructions or if you cannot read or write SFR data locations the Monitor-51 xdata memory area cannot be accessed from code space. The Monitor-51 data memory must be also *von Neumann* wired xdata/code space.

During operation the Monitor might report the following errors:

Error Text	Description
CONNECTION TO TARGET SYSTEM LOST	μ Vision2 has lost the serial connection to the Monitor program. This error might occur because your program re-initializes the serial interface used by Monitor-51. This error also occurs when you single step in the serial I/O routines of your application.
NO CODE MEMORY AT ADDRESS xxxx	You try to download code into ROM space or non-existing memory. The code memory must be von Neumann wired xdata/code RAM.
CANNOT WRITE INTERRUPT VECTOR	The Monitor program cannot install the interrupt vectors for the Serial interface. This error occurs when the code memory at address 0 cannot be accessed. Most likely this space is not von Neumann wired.

Debugging with Monitor-51

The HELLO and MEASURE examples that are described in “Chapter 7. Sample Programs” on page 149 are prepared for running on the Keil MCB517 test board.



To test the application with Monitor-51, select **Monitor-51** as target and build the project.



Then you may start the debug session. The μ Vision2 debugger connects to the MCB517 board, downloads the monitor and the application program. In case of communication problems a dialog box opens that displays further options and instructions.



Monitor-51 supports most μ Vision2 debugger features. You may single step through code, set breakpoints and run your application. Variables can be viewed with the standard debugger features. For information about “ μ Vision2 Restrictions when using Monitor-” refer to page 202.



The Keil Monitor-51 allows you to share the serial interface that is used for Monitor communication with user I/O. The **Serial Window #1** shows the *printf* and *putchar* output. Disable the option **Monitor Driver Settings – Serial Interrupt** to enter characters that are sent to the user program.

NOTES

*It is important that you skip the initialization of the serial interface in the user application, since the Monitor performs the UART setup. You may use conditional compilation as shown in our program examples. Also it is impossible to single step through **putchar** or **getkey** I/O functions.*



If the option **Monitor Driver Settings – Serial Interrupt** is enabled, you may stop program execution with **Halt** command from the **Debug** menu or the toolbar or type **ESC** in **Output Window – Command page**. The Monitor uses the serial interrupt to halt the user program. If the Monitor cannot stop your program (because the user application has disabled interrupts or so) a dialog box opens that displays further options and instructions.



The μ Vision2 **Reset** command sets the program counter to 0. However it should be noted that peripherals and SFRs of the 8051 device are not set into reset state. Therefore this command it is not identical with a hardware reset of the CPU.

11

Chapter 12. Command Reference

This chapter briefly describes the commands and directives for the Keil 8051 development tools. Commands and directives are listed in a tabular format along with a description.

NOTE

Underlined characters denote the abbreviation for the particular command or directive.

μ Vision 2 Command Line Invocation

The μ Vision2 IDE can directly execute operations on a project when it is called from a command line. The command line syntax is as follows:

```
UV2 [command] [projectfile]
```

command is one of the following commands. If no command is specified μ Vision2 opens the project file in interactive **Build Mode**.

projectfile is the name of a project file. μ Vision2 project files have the extension .UV2. If no project file is specify, μ Vision2 opens the last project file used.

Command	Description
-b	Build the project and exit after the build process is complete.
-d	Start μ Vision2 Debugging Mode. You can use this command together with a Debug Initialization File to execute automated test procedures. μ Vision2 will exit after debugging is completed with the EXIT command or stop debug session. Example: UV2 -d PROJECT1.UV2
-r	Re-translate the project and exit after the build process is complete.
-t targetname	Open the project and set the specified target as current target. This option can be used in combination with other μ Vision2 commands. Example: UV2 -b PROJECT1.UV2 -t"Monitor51" builds the target "C167CR Board" as defined in the PROJECT1.UV2 file. If the -t command option is not given μ Vision2 uses the target which was set as current target in the last project session.
-o outfile	copy output of the Output Window – Build page to the specified file. Example: UV2 -r PROJECT1.UV2 -o"listmake.prn"

A51 / A251 Macro Assembler Directives

Invocation:

```
A51 sourcefile [directives]
A251 @commandfile
```

sourcefile is the name of an assembler source file.

commandfile is the name of a file which contains a complete command line for the assembler including a **sourcefile** and **directives**.

directives are control parameters described in the following table.

A51 / A251 Controls	Meaning
CASE ‡	Enables case sensitive symbol names.
DATE(date)	Places date string in header (9 characters maximum).
DEBUG	Includes debugging symbol information in the object file.
ERRORPRINT[(filename)]	Outputs error messages to filename .
INCLUDE(filename)	Includes the contents of filename in the assembly.
MACRO	Enables standard macro processing.
MODBIN ‡	Selects 251 binary mode (default).
MODSRC ‡	Selects 251 source mode.
MPL	Enables Intel-style macro processing.
NOAMAKE	Excludes AutoMAKE information from the object file.
NOCOND	Excludes unassembled conditional assembly code from the listing file.
NOGEN	Disables macro expansions in the listing file.
NOLINES	Excludes line number information from the object file.
NOLIST	Excludes the assembler source code from the listing file.
NOMACRO	Disables standard macro processing.
NOMOD251 ‡	Disables enhanced 251 instruction set.
NOMOD51 †	Disables predefined 8051-specific special function registers.
NOSYMBOLS	Excludes the symbol table from the listing file.
NO_SYMLIST	Excludes symbol definitions from the listing file.
OBJECT[(filename)], NOOBJECT	Enables or disables object file output. The object file is saved as filename if specified.
PAGELENGTH(n)	Sets maximum number of lines in each page of listing file.
PAGEWIDTH(n)	Sets maximum number of characters in each line of listing file.
PRINT[(filename)], NOPRINT	Enables or disables listing file output. The listing file is saved as filename if specified.
REGISTERBANK(num, ...), NOREGISTERBANK	Indicates that one or more registerbanks are used or indicates that no register banks are used.
RESET (symbol, ...)	Assigns a value of 0000h to the specified symbols.
SET (symbol, ...)	Assigns a value of 0FFFFh to the specified symbols.

A51 / A251 Controls	Meaning
<u>TITLE</u> (<i>title</i>)	Includes <i>title</i> in the listing file header.
<u>XREF</u>	Includes a symbol cross reference listing in the listing file.

† These controls are available only in the A51 macro assembler.

‡ These controls are available only in A251 macro assembler.

C51/C251 Compiler

Invocation:

```
C51 sourcefile [directives]
C251 sourcefile [directives]
C51 @commandfile
C251 @commandfile
```

where

sourcefile is the name of a C source file.

commandfile is the name of a file which contains a complete command line for the compiler including a **sourcefile** and **directives**. You may use a command file to make compiling a source file easier or when you have more directives than fit on the command line.

directives are control parameters which are described in the following table.

C51 / C251 Controls	Meaning
<u>CODE</u>	Includes an assembly listing in the listing file.
<u>COMPACT</u>	Selects the COMPACT memory model.
<u>DEBUG</u>	Includes debugging information in the object file.
<u>DEFINE</u>	Defines preprocessor names on the command line.
<u>FLOATFUZZY</u>	Specifies the number of bits rounded during floating-point comparisons.
<u>HOLD</u> (<i>d,n,x</i>) ‡	Specifies size limits for variables placed in data (<i>d</i>), near (<i>n</i>), and xdata (<i>x</i>) memory areas.
<u>INTERVAL</u> †	Specifies the interval for interrupt vectors.
<u>INTR2</u> ‡	Saves upper program counter byte and PSW1 in interrupt functions.
<u>INTVECTOR</u> (<i>n</i>), <u>NOINTVECTOR</u>	Specifies offset for interrupt table, using <i>n</i> , or excludes interrupt vectors from the object file.
<u>LARGE</u>	Selects the LARGE memory model.
<u>LISTINCLUDE</u>	Includes the contents of include files in the listing file.

C51 / C251 Controls	Meaning
MAXARGS (<i>n</i>)	Specifies the number of bytes reserved for variable length argument lists.
MOD517 †	Enables support for the additional hardware of the Siemens 80C517 and its derivatives.
MODBIN ‡	Generates 251 binary mode code.
MODDP2 †	Enables support for the additional hardware of Dallas Semiconductor 80C320/520/530 and the AMD 80C521.
MODSRC ‡	Generates 251 source mode code.
NOAMAKE	Excludes AutoMAKE information from the object file.
NOAREGS †	Disables absolute register addressing using ARn instructions.
NOCOND	Excludes skipped conditional code from the listing file.
NOEXTEND	Disables 8051/251 extensions and processes only ANSI C constructs.
NOINTPROMOTE †	Disables ANSI integer promotion rules.
NOREGPARGS †	Disables passing parameters in registers.
OBJECT [(<i>filename</i>)], NOOBJECT	Enables or disables object file output. The object file is saved as filename if specified.
OBJECTEXTEND †	Includes additional variable type information in the object file.
OPTIMIZE	Specifies the level of optimization performed by the compiler.
ORDER	Locates variables in memory in the same order in which they are declared in the source file.
PAGELLENGTH (<i>n</i>)	Sets maximum number of lines in each page of listing file.
PAGEWIDTH (<i>n</i>)	Sets maximum number of characters in each line of listing file.
PARM51 ‡	Uses parameter passing conventions of the C51 Compiler.
PREPRINT [(<i>filename</i>)]	Produces a preprocessor listing file with all macros expanded. The preprocessor listing file is saved as filename if specified.
PRINT [(<i>filename</i>)], NOPRINT	Enables or disables listing file output. The listing file is saved as filename if specified.
REGFILE (<i>filename</i>)	Specifies the name of the generated file to contain register usage information.
REGISTERBANK †	Selects the register bank to use functions in the source file.
ROM ({ SMALL COMPACT LARGE })	Controls generation of AJMP and ACALL instructions.
SMALL	Selects the SMALL memory model.
SRC	Creates an assembly source file instead of an object file.
SYMBOLS	Includes a list of the symbols used in the listing file.
WARNINGLEVEL (<i>n</i>)	Controls the types and severity of warnings generated.

† These controls are available only in the C51 Compiler.

‡ These controls are available only in C251 compiler.

L51/BL51 Linker/Locator

Invocation:

```
BL51 inputlist [TO outputfile] [directives]
L51 inputlist [TO outputfile] [directives]
BL51 @commandfile
L51 @commandfile
```

where

- inputlist** is a list of the object files and libraries, separated by commas, that the linker includes in the final 8051 application.
- outputfile** is the name of the absolute object module the linker creates.
- commandfile** is the name of a file which contains a complete command line for the linker/locator including an **inputlist** and **directives**. You may use a command file to make linking your application easier or when you have more input files or more directives than fit on the command line.
- directives** are control parameters which are described in the following table.

BL51 Controls	Meaning
<u>B</u>ANKAREA ‡	Specifies the address range where the code banks are located.
<u>B</u>ANK_x ‡	Specifies the starting address, segments, and object modules for code banks 0 to 31.
<u>B</u>IT	Locates and orders BIT segments.
<u>C</u>ODE	Locates and orders CODE segments.
<u>C</u>OMMON ‡	Specifies the starting address, segments, and object modules to place in the common bank. This directive is essentially the same as the CODE directive.
<u>D</u>ATA	Locates and orders DATA segments.
<u>I</u>DATA	Locates and orders IDATA segments.
<u>I</u>XREF	Includes a cross reference report in the listing file.
<u>N</u>AME	Specifies a module name for the object file.
<u>N</u>OAMAKE	Excludes AutoMAKE information from the object file.
<u>N</u>ODEBUG<u>L</u>INES	Excludes line number information from the object file.
<u>N</u>ODEBUG<u>P</u>UBLICS	Excludes public symbol information from the object file.
<u>N</u>ODEBUG<u>S</u>YMBOLS	Excludes local symbol information from the object file.
<u>N</u>ODEFAULT<u>L</u>IBRARY	Excludes modules from the run-time libraries.
<u>N</u>OLINES	Excludes line number information from the listing file.
<u>N</u>OMAP	Excludes memory map information from the listing file.
<u>N</u>OOVERLAY	Prevents overlaying or overlapping local BIT and DATA segments.

BL51 Controls	Meaning
<u>NO</u>PUBLICS	Excludes public symbol information from the listing file.
<u>NO</u>SYMBOLS	Excludes local symbol information from the listing file.
<u>O</u>VERLAY	Directs the linker to overlay local data & bit segments and lets you change references between segments.
<u>P</u>AGELENGTH(<i>n</i>)	Sets maximum number of lines in each page of listing file.
<u>P</u>AGEWIDTH(<i>n</i>)	Sets maximum number of characters in each line of listing file.
<u>P</u>DATA	Specifies the starting address for PDATA segments.
<u>P</u>RECEDE	Locates and orders segments that should precede all others in the internal data memory.
<u>P</u>PRINT	Specifies the name of the listing file.
<u>R</u>AMSIZE	Specifies the size of the on-chip data memory.
<u>R</u>EGFILE(<i>filename</i>)	Specifies the name of the generated file to contain register usage information.
RTX51 ‡	Includes support for the RTX-51 full real-time kernel.
RTX51TINY ‡	Includes support for the RTX-51 tiny real-time kernel.
<u>S</u>TACK	Locates and orders STACK segments.
<u>X</u>DATA	Locates and orders XDATA segments.

‡ These controls are available only in the BL51 code banking linker/locator.

12

L251 Linker/Locator

Invocation:

```
L251 inputlist [TO outputfile] [directives]
L251 @commandfile
```

where

inputlist is a list of the object files and libraries, separated by commas, that the linker includes in the final 251 application.

outputfile is the name of the absolute object module the linker creates.

commandfile is the name of a file which contains a complete command line for the linker/locator including an **inputlist** and **directives**. You may use a command file to make linking your application easier or when you have more input files or more directives than fit on the command line.

directives are control parameters described in the following table.

L251 Controls	Meaning
<u>A</u>SSIGN	Defines public symbols on the command line.

L251 Controls	Meaning
<u>CLASSES</u>	Specifies a physical address range for segments in a memory class.
<u>IXREF</u>	Includes a cross reference report in the listing file.
<u>NAME</u>	Specifies a module name for the object file.
<u>NOAMAKE</u>	Excludes AutoMAKE information from the object file.
<u>NOCOMMENTS</u>	Excludes comment information from the listing file and the object file.
<u>NODEFAULTLIBRARY</u>	Excludes modules from the run-time libraries.
<u>NOLINES</u>	Excludes line number information from the listing file and object file.
<u>NOMAP</u>	Excludes memory map information from the listing file.
<u>NOOVERLAY</u>	Prevents overlaying or overlapping local BIT and DATA segments.
<u>NOPUBLICS</u>	Excludes public symbol information from the listing file and the object file.
<u>NOSYMBOLS</u>	Excludes local symbol information from the listing file.
<u>NOTYPES</u>	Excludes type information from the listing file and the object file.
<u>OBJECTCONTROLS</u>	Excludes specific debugging information from the object file. Subcontrols must be specified in parentheses. See NOCOMMENTS , NOLINES , NOPUBLICS , NOSYMBOLS , and PURGE .
<u>OVERLAY</u>	Directs the linker to overlay local data & bit segments and lets you change references between segments.
<u>PAGELLENGTH</u>(n)	Sets maximum number of lines in each page of listing file.
<u>PAGEWIDTH</u>(n)	Sets maximum number of characters in each line of listing file.
<u>PRINT</u>	Specifies the name of the listing file.
<u>PRINTCONTROLS</u>	Excludes specific debugging information from the listing file. Subcontrols must be specified in parentheses. See NOCOMMENTS , NOLINES , NOPUBLICS , NOSYMBOLS , and PURGE .
<u>PURGE</u>	Excludes all debugging information from the listing file and the object file.
<u>RAMSIZE</u>	Specifies the size of the on-chip data memory.
<u>REGFILE</u>(filename)	Specifies the name of the generated file to contain register usage information.
<u>RESERVE</u>	Reserves memory ranges and prevents the linker from using these memory areas.
RTX251	Includes support for the RTX-251 full real-time kernel.
RTX251TINY	Includes support for the RTX-251 tiny real-time kernel.
<u>SEGMENTS</u>	Defines physical memory addresses and orders for specified segments.
<u>SEGSIZE</u>	Specifies memory space used by a segment.
<u>WARNINGLEVEL</u>(n)	Controls the types and severity of warnings generated.

LIB51 / L251 Library Manager Commands

The LIB51 / LIB251 Library Manager lets you create and maintain library files of your 8051 / 251 object modules. Invoke the library manager using the following command:

```
LIB51 [command]
LIB251 @commandfile
```

command is one of the following commands. If no command is specified LIB51 / LIB251 enters an interactive command mode.

commandfile is the name of a file which contains a complete command line for the library manager. The command file includes a single *command* that is executed by LIB51. You may use a command file to generate a large library with at once.

12

LIB51 Command	Description
<u>A</u>DD	Adds an object module to the library file. For example, LIB51 ADD GOODCODE.OBJ TO MYLIB.LIB adds the GOODCODE.OBJ object module to MYLIB.LIB .
<u>C</u>REATE	Creates a new library file. For example, LIB251 CREATE MYLIB.LIB creates a new library file named MYLIB.LIB .
<u>D</u>ELETE	Removes an object module from the library file. For example, LIB51 DELETE MYLIB.LIB (GOODCODE) removes the GOODCODE module from MYLIB.LIB .
<u>E</u>XTRACT	Extracts an object module from the library file. For example, LIB251 EXTRACT MYLIB.LIB (GOODCODE) TO GOOD.OBJ copies the GOODCODE module to the object file GOOD.OBJ .
<u>E</u>XIT	Exits the library manager interactive mode.
<u>H</u>ELP	Displays help information for the library manager.
<u>L</u>IST	Lists the module and public symbol information stored in the library file. For example, LIB251 LIST MYLIB.LIB TO MYLIB.LST PUBLICS generates a listing file (named MYLIB.LST) that contains the module names stored in the MYLIB.LIB library file. The PUBLICS directive specifies that public symbols are also included in the listing.
<u>R</u>EPLACE	Replaces an existing object module to the library file. For example, LIB51 REPLACE GOODCODE.OBJ IN MYLIB.LIB replaces the GOODCODE.OBJ object module in MYLIB.LIB . Note that Replace will add GOODCODE.OBJ to the library if it does not exist.

LIB51 Command	Description
<u>T</u>RANSFER	Generates a complete new library and adds object modules. For example, <code>LIB251 TRANSFER FILE1.OBJ, FILE2.OBJ TO MYLIB.LIB</code> deletes the existing library <code>MYLIB.LIB</code> , re-creates it and adds the object modules <code>FILE1.OBJ</code> and <code>FILE2.OBJ</code> to that library.

OC51 Banked Object File Converter

Invocation: `OC51 banked_file`

where

`banked_file` is the name of a banked object file.

OH51 Object-Hex Converter

Invocation: `OH51 absfile [HEXFILE(hexfile)]`

where

`absfile` is the name of an absolute object file.

`hexfile` is the name of the Intel HEX file to create.

OH251 Object-Hex Converter

Invocation: `OH251 absfile [HEXFILE(hexfile)] [{HEX|H386}]
[RANGE(start-end)]`

where

`absfile` is the name of an absolute object file.

`hexfile` is the name of the HEX file to create.

`HEX` specifies that a standard Intel HEX file is created.

`H386` specifies that an Intel HEX-386 file is created.

`RANGE` specifies the address range of data in the `absfile` to convert and store in the HEX file. The default range is `0xFF0000` to `0xFFFFFFF`.

`start` specifies the starting address of the range. This address must be entered in C hexadecimal notation, for example: `0xFF0000`.

end specifies the ending address of the range. This address must be entered in C hexadecimal notation, for example: **0xFFFFF**.

Index

\$

\$ system variable 113

*

*.OPT file 77

*.UV2 file 77

=

break system variable 113

_getkey library routine 190

iip system variable 113

_RBYTE debug function 134,139

_RDOUBLE debug function 139

_RDOUBLEdebug function 134

_RDWORD debug function 134,139

_RFLOAT debug function 134,139

_RWORD debug function 134,139

TaskRunning debug function 134

_WBYTE debug function 134,140

_WDOUBLE debug function ... 134,140

_WDWORD debug function 134,140

_WFLOAT debug function 134,140

_WWORD debug function 134,140

μ

μVision2 debugger

 Description 15

μVision2 Debugger 93

μVision2 IDE 21,58

 Command line parameters 211

 Debug Options 102

 Description 13

 Menu commands 23

 Options 62

 Shortcuts 23

 Toolbars 23

 Toolbox 101

A

A/D converter 195

 Example program 195

A51

 Assembler kit 17

A51 assembler

 Description 14

A51 macro assembler 49

 Commands 212

 Directives 212

Access Break 97

Add command

 library manager 218

Additional items, document

 conventions 4

Advanced GDI 15

alien 43

Analog/Digital converter 195

ANSI C 147

asm 42

Assembler Instructions 95

Assembler kit 17

Assistance 12

B

Banked memory prefix 123

Banking 67

Binary constants 111

Bit addresses 122

BIT memory prefix 123

BL51 code banking

 linker/locator 51

 Code Banking 51

 Common Area 52

 Data Address Management 51

 Executing Functions in Other

 Banks 52

BL51 linker/locator

 Description 14

Bold capital text, use of 4

Braces, use of 4

break 131

Breakpoint Commands 108

Breakpoints 96

 Access Break 97

 Conditional 97

Execution Break.....	97	can_unbind_obj.....	175
Build Process.....	83	can_wait.....	175
Build Project.....	63	can_write.....	175
		case.....	131
C		Changes to the documentation.....	10
		Character constant escape	
C startup code.....	197	sequence.....	112
C51 C compiler.....	32	Character constants.....	112
Language Extensions.....	33	Choices, document conventions.....	4
C51 compiler		Code Banking.....	67
Description.....	14	Code Coverage.....	104
Generic pointers.....	37	CODE memory prefix.....	123
Library routines.....	45	COM Port for Serial I/O.....	128
Memory specific pointers.....	38	Command Input from File.....	128
Typed pointers.....	38	Command reference.....	211
Untyped pointers.....	37	A51 macro assembler.....	212
C51 Compiler		LIB51 / LIB251 library	
Code Optimizations.....	43	manager.....	218
Compact model.....	36	Commands.....	23
Data Types.....	33	Edit.....	24
Debugging.....	45	File.....	23
Function Return Values.....	41	Selecting text.....	25
Interfacing to Assembly.....	42	COMPACT.....	35,36
Interfacing to PL/M-51.....	43	Comparison chart.....	17
Interrupt Functions.....	40	Compiler kit.....	16
Large model.....	36	conditional assembly.....	49
Memory Models.....	35	Conditional Break.....	97
Memory Types.....	34	Configuration	
Parameter Passing.....	40	CPU.....	197
Pointers.....	37	tool options.....	66
Real-Time Operating System		Constant Expressions.....	111
Support.....	41	Constants.....	111
Reentrant Functions.....	39	Binary.....	111
Register Optimizing.....	41	Character.....	112
Small model.....	35	Decimal.....	111
CA51		Floating-point.....	112
Compiler kit.....	16	HEX.....	111
can_bind_obj.....	175	Octal.....	111
can_def_obj.....	175	String.....	113
can_get_status.....	175	constants in a code bank.....	68
can_hw_init.....	175	continue.....	131
can_read.....	175	Control Directives	
can_receive.....	175	#pragma.....	46
can_request.....	175	Copy Tool Settings.....	85
can_send.....	175	Correct syntax errors.....	63
can_start.....	175	Counter Clock Inputs.....	127
can_stop.....	175	Counters.....	189
can_task_create.....	175		

Courier typeface, use of 4
 CPU driver symbols 114
 CPU initialization 197
 CPU pin register *See* VTREG
 CPU Registers 100
 CPU Simulation 94
 Create a Library 85
 Create a Project File 58
 Create command
 library manager 218
 Create HEX File 63
 Custom Translator 90

D

D/A converter 194
 Example program 194
 DATA memory prefix 123
 Data Types 81
 Debug Commands 28,107
 Memory 108
 Program Execution 108
 Debug Commands from File 128
 Debug functions 131,147
 _RBYTE 134,139
 _RDOUBLE 134,139
 _RDWORD 134,139
 _RFLOAT 139
 _RFOAT 134
 _RWORD 134,139
 TaskRunning 134,139
 _WBYTE 134,140
 _WDOUBLE 134,140
 _WDWORD 134,140
 _WFLOAT 134,140
 _WWORD 134,140
 exec 134,135
 getdbl 134,135
 getint 134,135
 getlong 134,135
 memset 134,135
 printf 134,136
 rand 134,136
 rwatch 134,138
 swatch 134,137
 twatch 134,137
 wwatch 134,138
 Debug Menu 28
 Debug Mode 94
 Debug Output
 protocol file 129
 Debugger 93
 Debugger capabilities 126
 Debugging with Monitor-51 209
 Decimal constants 111
 Delete command
 library manager 218
 Developer's kit 16
 Development cycle 13
 Development tools 21
 Device Database 84
 Digital/Analog converter 194
 Example program 194
 Directives
 A51 macro assembler 212
 LIB51 / LIB251 library
 manager 218
 Directory structure 20
 Disassembly Window 95
 Displayed text, document
 conventions 4
 DK51
 Developer's kit 16
 do 131
 Document conventions 4
 Documentation changes 10
 Double brackets, use of 4

E

EA register 187
 Easy-Case 75
 Edit Menu 24
 Editor Commands 24
 Ellipses, use of 4
 Ellipses, vertical, use of 4
 else 131
 endasm 42
 Escape sequence 112
 Evaluation board 199
 Evaluation kit 11
 Evaluation users 11
 Example program
 A/D converter 195
 D/A converter 194
 Parallel port I/O 188

Serial interface	190
Timers/Counters.....	189
Watchdog timer	193
Examples of expressions.....	124
Exclude from Link Run	65
exec debug function.....	134,135
Execution Break	97
Exit command	
library manager	218
Experienced users.....	11
Expression components	
Bit addresses	110,122
Constants.....	110,111
CPU driver symbols.....	114
Line numbers	110,122
Memory spaces	123
Operators	110,123
Program variables	110,118
SFRs.....	114
Special function registers	114
Symbols	110,118
System variables	110,113
Type specifications	110,123
Variables	110,118
VTREGs	114
Expression examples	124
Expressions.....	110
Extract command	
library manager	218

F

Feature check list.....	17
File Attributes.....	65
File Code for Tool Parameters	71
File Commands.....	23
Debug.....	28
Project.....	27
File Extensions	92
File Menu	23
File specific Options.....	65,66,87
Filename, document conventions.....	4
Files Groups	64
Find in Files.....	69
Floating-point constants.....	112
Folder for Listing Files	84
Folder for Object Files	84
Folder structure.....	20

FR51	
Real-time operating system	17
Fully qualified symbols.....	119
Function classes	
Predefined functions.....	133
Signal functions.....	133
User functions	133
Function Classes	133
Functions	
μ Vision2 Debug Functions.....	131
Classes.....	133
Creating.....	131
Invoking	133
Predefined debug functions	134
Signal	143
User	141

G

General commands.....	109
getdbl debug function.....	134,135
getint debug function	134,135
getlong debug function.....	134,135
Getting help.....	12
Getting started immediately	10
Global Register Optimization	79
goto	131
Group Attributes	65
Group specific Options	
for Groups	65,66,87

H

Hardware requirements	19
Help	12
Help command	
library manager	218
Help Menu	31
HEX constants	111
HEX File.....	63

I

I/O Port simulation.....	126
I/O ports	116,187
IBPSTACK.....	197
IBPSTACKTOP	198
IDATA memory prefix	123

IDATALEN 197
 Idle Mode 196
 IE register 187
 if131
 Illegal Memory Accesses 128
 Import μ Vision1 Projects 82
 Include specific Library Modules
 89
 Initializing memory 197
 Input from File 128
 Installation details 19
 Installing the software 19
 Intel PL/M-51 91
 interrupt 40
 Interrupt
 Addresses 185
 Numbers 185
 Interrupt enable registers 187
 Interrupt functions 185
 Interrupt simulation 127
 Introduction 9
 IP register 187
 isr_rcv_message 174
 isr_send_message 174
 isr_send_signal 174
 Italicized text, use of 4
 itrace system variable 113

K

Kernel Aware Debugging 130,180
 Kernel Awareness
 for Real-Time Operating
 Systems 180
 Key names, document
 conventions 4
 Key Sequence for Tool
 Parameters 71
 Keyboard Shortcuts 129
 Kit comparison 17

L

LARGE 35,36
 Last minute changes 10
 Latch Devices
 simulation of ~ 127
 LIB51 / L251 library manager

Commands 218
 LIB51 library manager 54
 Description 14
 Library 88,89
 library manager
 Add command 218
 Create command 218
 Delete command 218
 Exit command 218
 Extract command 218
 Help command 218
 List command 218
 Replace command 218
 Transfer command 219
 Line numbers 122
 List command
 library manager 218
 Listing Files 84
 Literal 121
 Literal symbols 121
 Load Memory Contents 129
 Locate Segments 66,86

M

Macros
 Macro Processing Language 49
 MPL 49
 Standard macros 49
 Manual topics 10
 Memory Banking 67
 Memory Map 105
 Memory Model 62,78
 Memory space
 BIT 123
 CODE 123
 Code Banks 123
 DATA 123
 IDATA 123
 XDATA 123
 Memory spaces 123
 Memory Type 62,78
 Memory Window 100
 memset debug function 134,135
 Menu 23
 Debug 28
 Edit 24
 File 23

Help	31
Peripherals	29
Project	27
SVCS	30
Tools	29
View	26
Window	30
Microsoft SourceSafe	76
MKS Source Integrity	76
Module names	118
Modules in a code bank	67
Monitor driver	201
Monitor-51	199
Configuration	206
Debug Example Programs	209
Description	15
Problems	208
Serial transmission line	201
MPL	49

N

Naming conventions for symbols	118
New Project	58
New users	11
Non-qualified symbols	120
NOOVERLAY	51
NOREGPARMS	40,42

O

Object Files	84
OBJECTTEXTEND	45
OC51 Banked Object File	
Converter	55
Octal constants	111
OH51 Object-Hex Converter	55
oi_reset_int_mask	174
oi_set_int_mask	174
OMF51	43,45
Omitted text, document	
conventions	4
On-chip peripherals	183
Operators	123
Optimum Code	78
Optional items, document	
conventions	4
Options	

for Files	65,66,87
for Groups	65,66,87
os_attach_interrupt	174
os_check_mailbox	174
os_check_mailboxes	174
os_check_pool	174
os_check_semaphore	174
os_check_semaphores	174
os_check_task	174
os_check_tasks	175
os_clear_signal	174
os_create_pool	174
os_create_task	174
os_delete_task	174
os_detach_interrupt	174
os_disable_isr	174
os_enable_isr	174
os_free_block	174
os_get_block	174
os_send_message	174
os_send_signal	174
os_send_token	174
os_set_slice	174
os_wait	174
os-wait	171
Output Window	63
OVERLAY	51

P

Parallel port	187
Example program	188
Parameters for external tools	71
Part numbers	16
PBPSTACK	198
PBPSTACKTOP	198
PC-Lint	74
PDATALEN	197
PDATASTART	197
Performance Analyzer	103
Peripherals	183
Peripherals Menu	29
PK51	
Professional developer's kit	16
PL/M-51	91
Port I/O	187
Ports	116
Power Down Mode	196

Power reduction modes..... 196
 PPAGE 198
 PPAGEENABLE 198
 Predefined debug functions..... 134
 _RBYTE 134,139
 _RDOUBLE..... 134,139
 _RDWORD..... 134,139
 _RFLOAT 139
 _RFOAT 134
 _RWORD..... 134,139
 TaskRunning 134,139
 _WBYTE 134,140
 _WDOUBLE..... 134,140
 _WDWORD..... 134,140
 _WFLOAT 134,140
 _WORD 134,140
 exec 134,135
 getdbl 134,135
 getint 134,135
 getlong..... 134,135
 memset 134,135
 printf..... 134,136
 rand 134,136
 rwatch..... 134,138
 swatch 134,137
 twatch..... 134,137
 wwatch 134,138
 Preemptive Task Switching 172
 Preset I/O Ports or Memory 129
 Printed text, document
 conventions 4
 printf debug function..... 134,136
 printf library routine..... 190
 Product comparison 17
 Product link..... 16
 Product overview 16
 Production kit 11
 Professional developer's kit..... 16
 Program counter system variable 113
 Project Commands 27
 Project Menu..... 27
 Project Targets 64
 Project Window 65
 Protocol Debug Output 129
 putchar library routine 190
 PVCS from Intersolv 76

Q

Qualified symbols..... 119

R

radix system variable..... 113
 rand debug function..... 134,136
 Read only attribute 65
 Real-time operating system 17
 reentrant 39
 Register banks 184,186
 Registers
 EA..... 187
 IE..... 187
 IP 187
 REGPARMS 40
 Replace command
 library manager..... 218
 Requesting assistance 12
 Requirements..... 19
 Round-Robin 170
 RS-232 ports 117,190
 RTX51..... 169
 Real-time operating system..... 17
 Routines..... 174
 Status Information 181
 Task List..... 181
 Technical Data..... 173
 RTX-51 Application Example
 TRAFFIC..... 176
 RTX51 real-time operating
 system
 Description 15
 RTX51 Tiny
 Introduction 169
 Run Program 99
 rwatch debug function..... 134,138

S

Sans serif typeface, use of 4
 Saving power..... 196
 scanf library routine 190
 segments in a code bank 68
 Selecting text 25
 Serial I/O to PC COM Port 128
 Serial interface 190

Example program.....	190
Serial ports.....	117
Serial Window.....	103
SETUP program.....	19
SFRs.....	114
Siemens Easy-Case.....	75
Signal functions.....	143
Simulation of complex Hardware.....	126
Simulating I/O ports.....	116
Simulating serial ports.....	117
Simulation.....	94
Simulator.....	93
Single Step Program.....	99
Single-board computers.....	199
SMALL.....	35,36
Software development cycle.....	13
Software requirements.....	19
Software Version Control	
Systems.....	76
Source Browser.....	69
Source Integrity from MKS.....	76
SourceSafe from Microsoft.....	76
Special function registers.....	114
Special Function Registers.....	183
Specify a Code Bank for a	
Module.....	67
SRC.....	42
Start μ Vision2.....	58
Start Debugging.....	94
Start External Tools.....	83
Startup code.....	197
STARTUP.A51.....	60
states system variable.....	113
String constants.....	113
SVCS Menu.....	30
swatch debug function.....	134,137
switch.....	131
Symbol expressions.....	118
Symbols	
CPU driver.....	114
Fully qualified.....	119
Literals.....	121
Module names.....	118
Naming conventions.....	118
Non-qualified.....	120
Qualified names.....	119
SFRs.....	114
Special function registers.....	114
System variables.....	113
VTREGs.....	114
Symbols Window.....	106
Syntax errors.....	63
System variables.....	113
\$.....	113
_break.....	113
cycles.....	113
itrace.....	113
Program counter.....	113
radix.....	113
T	
Target hardware.....	199
Target Tool Settings.....	85
Task Information	
for RTX51.....	181
Task status.....	181
of RTX51 functions.....	181
TaskRunning debug function.....	139
Technical support.....	12
Test RTX Applications.....	178
Timer 0.....	189
Timer 1.....	189
Timer 2.....	189
Timer/Counter Clock Inputs.....	127
Timers.....	189
Timers/Counters	
Example program.....	189
Tool Information.....	92
tool options.....	66
Tools Menu.....	29,72,76
Tools Parameters	
Key Sequence.....	71
Topics.....	10
Transfer command	
library manager.....	219
Translate asm/endasm sections.....	89
twatch debug function.....	134,137
Type specifications.....	123
Types of users.....	11
U	
UART.....	103
User functions.....	141

Users 11
 using 40
 Using a Software Version
 Control System 30,65,72,76
 Using monitor-51 199
 Utilities 69

V

Variable expressions 118
 Variable values 99
 Variables, document conventions 4
 Version Control Systems 76
 Vertical bar, use of 4
 Vertical ellipses, use of 4
 View memory contents 100
 View Menu 26
 VTREGs 114

W

Wait for Signal 172
 Wait for Timeout 171
 Watch Window 99
 Watchdog timer 193
 Example program 193
 while 131
 Window Menu 30
 Working with a Software Team 76
 Write Debug Output to file 129
 Write Optimum Code 78
 wwatch debug function 134,138

X

XBPSTACK 198
 XBPSTACKTOP 198
 XDATA memory prefix 123
 XDATALEN 197
 XDATASTART 197